



Voluntary IBR Standards Update

Conformity Assessment, Planned Revisions,
and Emerging GFM Requirements

Jens Boemer, Jose Cordova, EPRI
Alex Shattuck, ESIG
Andy Hoke, NLR (formerly known as NREL)

ESIG/EPRI/G-PST Webinar
20 January 2026

Agenda

- Introduction by ESIG (**Alex**)
- Overview on G-PST GPST Pillars 1 and 4 (**Jens**)
- Update on IEEE P2800.2 publication (**Andy**)
- IEEE P2800.2 Conformity Assessment of generic GFL and GFM models (**Jose**)
- Update on IEEE P2800/.x PARs (**Jens**)
- Update on related IEC standards activities (**Alex**)
- Update on UNIFI GFM Specifications V3 document (**Andy**)
- Summary & Q&A (**Slido & Moderated Discussion**)



Introduction to G-PST GPST Pillars 1 and 4

G-PST Pillars Overview

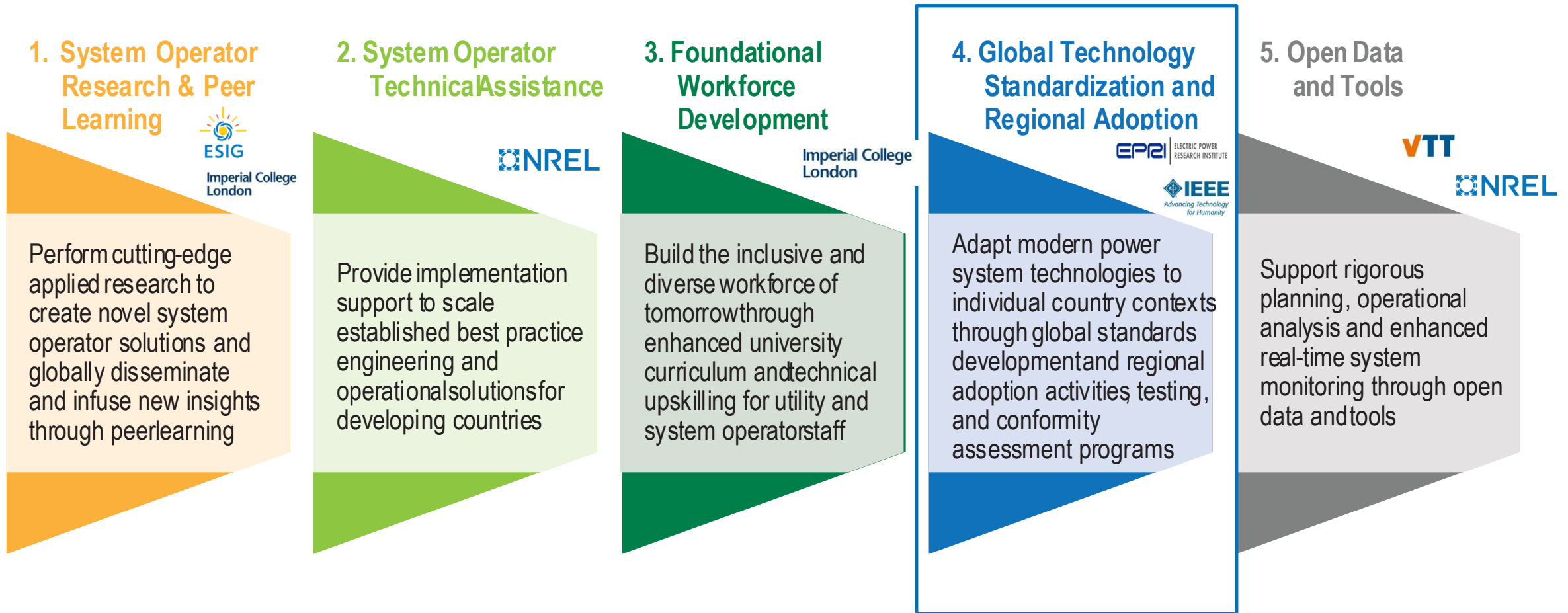

Updated G-PST Pillar 4 Website

GLOBAL PST CONSORTIUM About G-PST ▾ What We Do ▾ Where We Work ▾ Our Impact News & Events Resources ▾ GET INVOLVED Q

Key Action Pillars

The G-PST Consortium engages in activities across five key pillars with the goal of ensuring global coordination of our efforts toward the achievement of cost-efficient, clean, and reliable power systems.

PILLAR 1
System Operator Research & Peer Learning
Perform and globally disseminate cutting edge applied research to solve pressing challenges for the world's leading system operators.

PILLAR 2
System Operator Technical Support
Provide implementation support to scale established best practice engineering and operational solutions for developing country system operators.

PILLAR 3
Foundational Workforce Development
Build the inclusive and diverse workforce of tomorrow through enhanced university curriculum and technical upskilling for utility and system operator staff.

PILLAR 4
Global Technology Standardization & Regional Adoption
Adapt modern power system technologies to individual country contexts through standards development activities and testing programs.

GLOBAL PST CONSORTIUM About G-PST ▾ What We Do ▾ Where We Work ▾ Our Impact News & Events Resources ▾ GET INVOLVED Q

Global Technology Standardization & Regional Adoption

Pillar 4 – Global Technology Standardization & Regional Adoption

The Electric Power Research Institute (EPRI), as the Pillar 4 coordinator, supports the development of key technology standards at the national, regional, and global level, to advance power system transformation. In addition, EPRI, Institute of Electrical and Electronics Engineers (IEEE), and the Pillar 4 team support countries with applying these technologies and standards at the local level.

Pillar 4 has been deeply involved in standards for development and interconnection of large-scale inverter-based resources. The team is working with a broad group of partners on standards related to grid-forming technologies. It has also supported more widespread utilization of distributed energy resources through implementation support for relevant standards in jurisdictions around the world.

This work translates into infrastructure projects on the ground when G-PST's partner countries adopt or modify the standards for their contexts. G-PST has worked or is working to support the development and implementation of standards in the United States, Panama, India, Chile, Colombia and Brazil. Regional or global standards streamline the process for technology manufacturers, power system operators, and regulators and accelerate the deployment of new technologies critical for advancing power system transformation.

IEEE, part of G-PST's Core Team and a key player in Pillar 4, completed a white paper in 2020 providing an overview of power system technical standards, testing and certification most applicable to G-PST activities.

[VIEW PILLAR 4 RESOURCES](#)

<https://globalpst.org/what-we-do/adoption-support/>



Update on IEEE P2800.2 publication

IEEE standards for transmission-connected IBRs

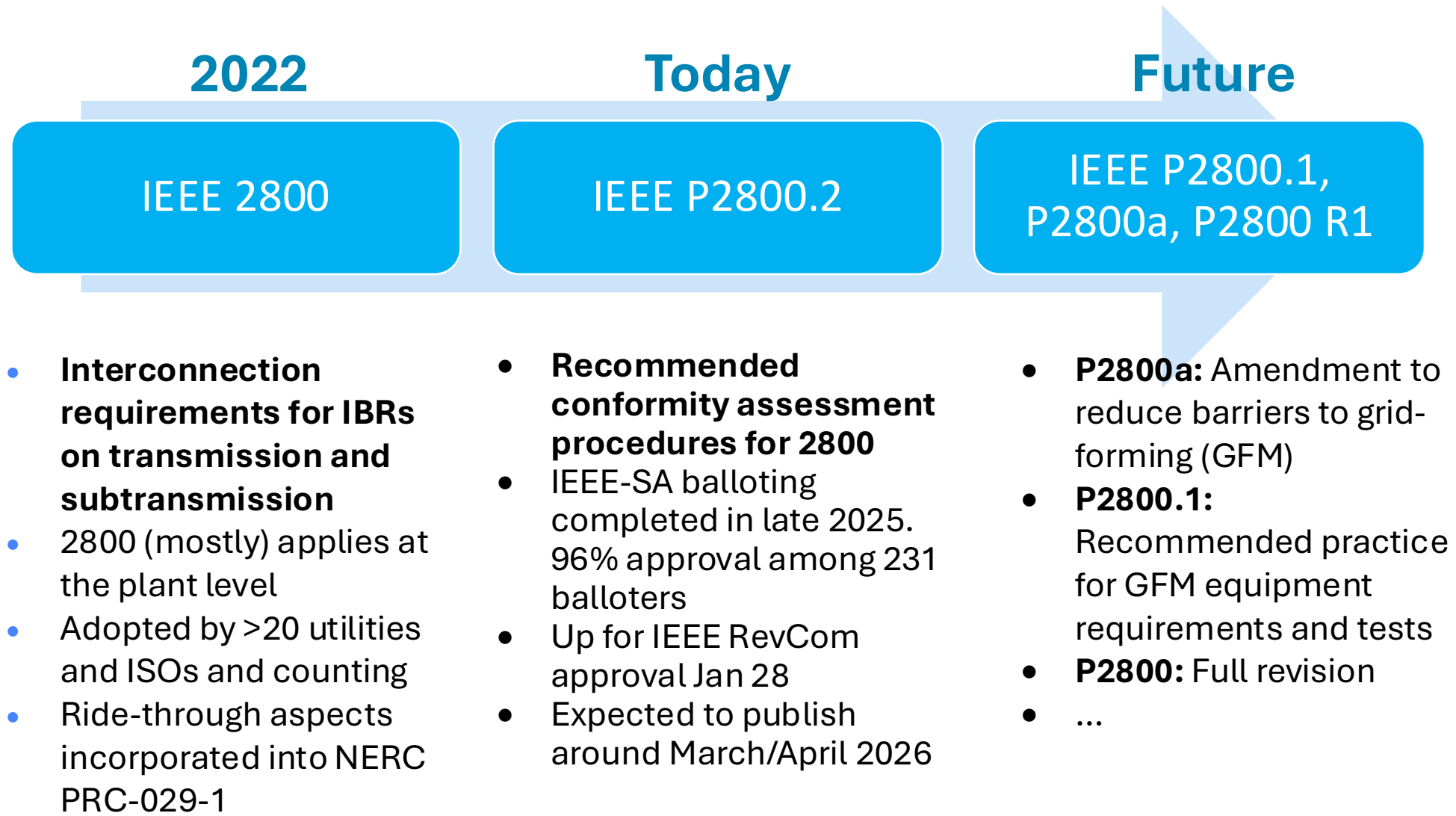

Source: Andy Hoke (NLR, formerly known as NREL)

Verification: IEEE 2800 and P2800.2 Conformity Framework

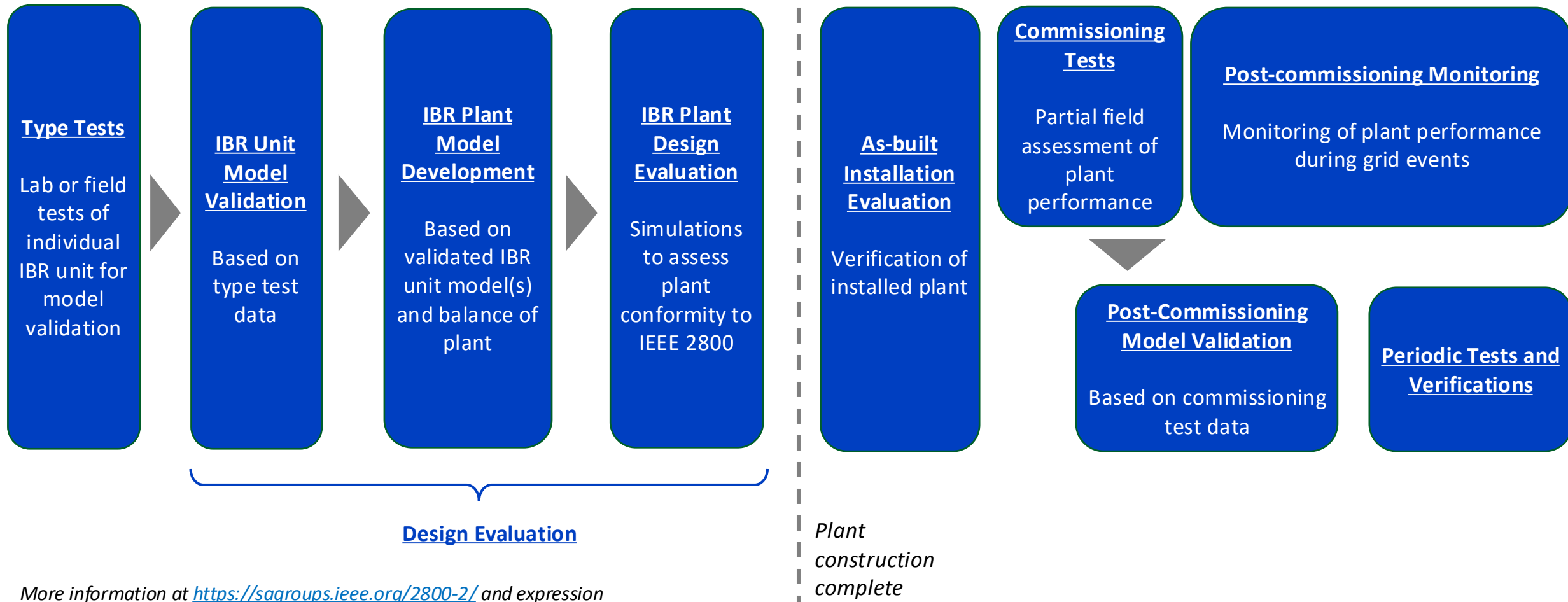

More information at <https://sagroups.ieee.org/2800-2/> and expression of interest to participate [here](#).

IEEE P2800.2 is expected for publication in early 2026.



**IEEE P2800.2 Conformity Assessment of generic GFL
and GFM models**

Conformity Assessment of Generic IBR EMT Models

Research Questions

1. *Are the modeling-based IBR plant design evaluation tests specified in IEEE P2800.2, Clause 7, practical and reasonable?*
2. *For a given short-circuit ratio (SCR) at an IBR plant's point of measurement (POM), can a generic IBR model be configured with a single set of control parameter values such that its performance falls within the conformity ranges specified in IEEE 2800-2022 for the selected P2800.2 tests?*
3. *Can a single IBR plant configuration and parameter set be identified that produces a stable response for a range of SCR values?*
4. *How do the answers to the questions above differ between grid-forming (GFM) and non-GFM inverter-based resources?*

Source: [3002034299](#)

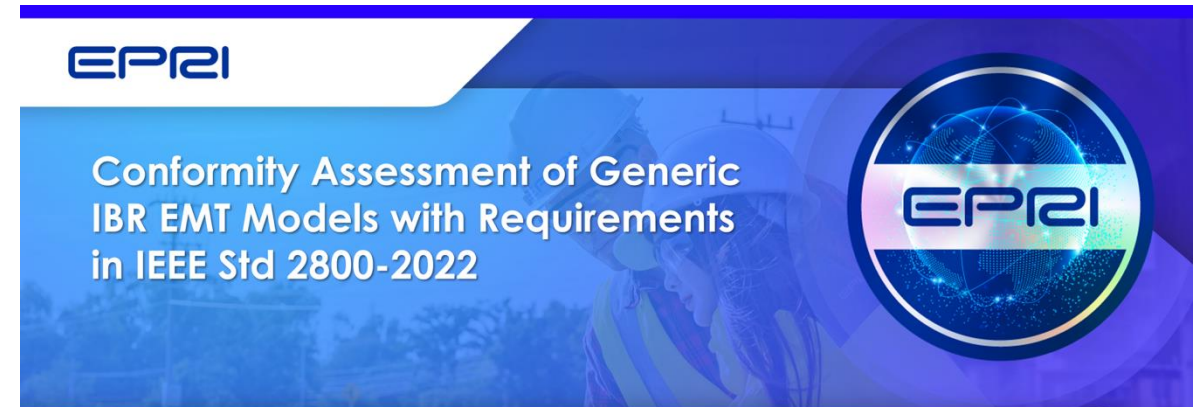

Project Manager
D. Ramasubramanian
3002034299
November 2025

in x f
www.epri.com | © 2025 Electric Power Research Institute, Inc. All rights reserved.

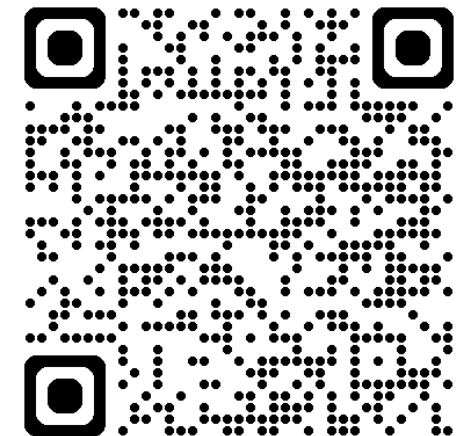

Conformity Assessment of Generic IBR EMT and PDT Models with Requirements in IEEE Std 2800-2022/IEEE 2800.2 (draft 4.0)

External Grid (Controllable AC source)

- External grid represented within EPRI's **IBR-ID/CA Tool**
- Runs IEEE P2800.2 tests and visualizes results automatically
- Flexibility to test both generic and user defined models
- Adjustable impedance to simulate different grid strength, e.g., SCR = 2.5 and 20

IBR Plant

- All IBR plant measurements and controls are at the POM (Default RPA per IEEE 2800)
- EMT and PDT models
- PSCAD: [PV-MOD PPC EMT model](#)
- PSS®E: [REPCA1](#)

Generic Grid-following Inverter Unit (PV-MOD Milestone 2.7.3)

- No local voltage control or frequency response: following PPC's P and Q set-points (FFR and local V-control disabled)
- PSCAD: PV-MOD unit EMT model
- PSS®E : REECA1 and REGCCU (EPRI) models

Generic Inverter Unit with AGS (Model specifications)

IBR unit with Advanced Grid Support (AGS) functions holds internal voltage and frequency reference (effectively providing FFR and local V-control)

- DROOP or VSM CONTROL MODE
- PSCAD: GFM unit EMT model

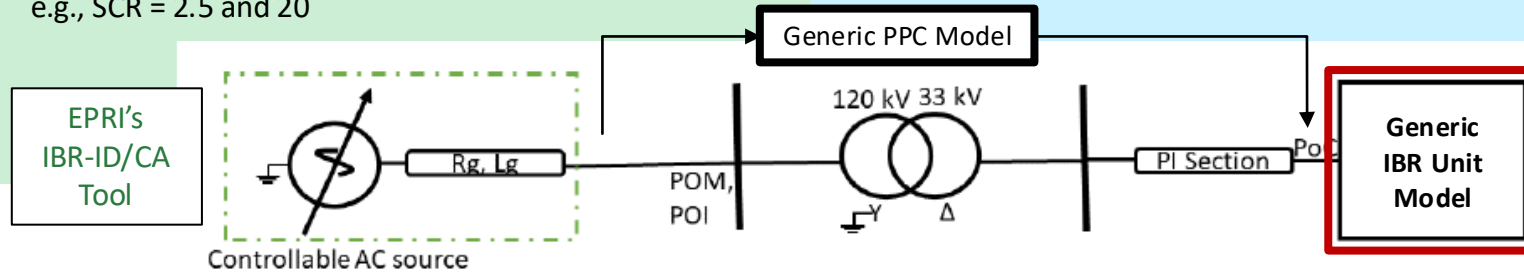

Step 1
Select tests from IEEE P2800.2 D4.0 (e.g., voltage and frequency ride-through, voltage control, phase-angle jump, etc.)

Step 2
Configure the IBR plant and equipment models with a parameter set and a specific grid condition (SCR)

Step 3
Apply EPRI IBR Performance Identification Tool (IBR-ID) v1.0 to run all selected tests

Step 4
Manual/visual inspection of "conformity" based on plots produced by the IBR-ID tool

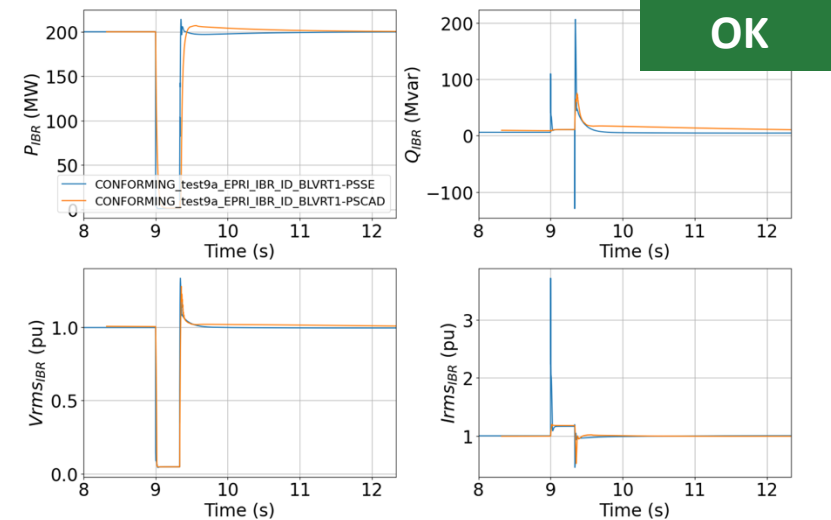

| Scenarios | SCR | | | | | | | |
|--|-------|------|-------|------|-------|------|-------|------|
| | 2.5 | | 3.0 | | 5.0 | | 20 | |
| | PSCAD | PSSE | PSCAD | PSSE | PSCAD | PSSE | PSCAD | PSSE |
| Balanced low-voltage disturbance ride-through tests (EMT and PDT) for IBR plants without active power absorption capability - Table 43/D4.1 | | | | | | | | |
| BLVRT#1 | OK | OK | OK | OK | OK | OK | OK | OK |



**CONFORMITY TO IEEE P2800.2 TESTS
GENERIC GRID-FOLLOWING IBR MODEL**

Test Scenarios and Cases (Subset of IEEE P2800.2 D4.0)

| Scenario | IBR Unit's nameplate rating [kVA] | Number of IBRs connected to MITS | apparent power installed capacity (Sagg) [MVA] | active power installed capacity (Pagg) [MW] | IBR continuous rating (ICR) [MW] | minimum active power capability (pmin) [pu@ICR] | available active power (Pavl) [MW] Note: may be at the DC side of the IBR units | Dispatch / Curtailment [pu@Sagg] | actual active power (Pact, p) [MW] | Measurements [pu@Sagg] |
|-----------------------|-----------------------------------|----------------------------------|--|---|----------------------------------|---|--|----------------------------------|------------------------------------|------------------------|
| P2800.2 Pact = ICR | 1 MVA | 211 | 211 MVA | 200 MW | 200 MW | 0.01 * ICR | 1.0 * ICR | 0.95 pu (200 MW) | 1.0 * ICR (200 MW) | P_IBR = 0.95 pu |

Voltage or reactive power control tests (EMT and PDT) for IBR plants without active power absorption capability - Table 41/D4.1

| Test number | Event | IBR plant active power | IBR plant reactive power |
|----------------------|---|------------------------|--------------------------|
| VC#1 – Negative step | RPA voltage step change as per Figure 41 (D4.0) | ICR | 0 |
| VC#1 – Positive step | RPA voltage step change as per Figure 41 (D4.0) | ICR | 0 |

Balanced low-voltage disturbance ride-through tests (EMT and PDT) for IBR plants without active power absorption capability - Table 43/D4.1

| Test Number | Fault type | Residual voltage (pu) | Duration (s) | IBR plant active power | IBR plant reactive power |
|-------------|------------|-----------------------|--------------|------------------------|--------------------------|
| BLVRT#1 | 3PHG | 0.00 | 0.32 | ICR | 0 |

Balanced high-voltage disturbance ride-through tests (EMT and PDT) for IBR plants without active power absorption capability - Table 44/D4.1

| Test Number | Balanced voltage at RPA (pu) | Duration (s) | IBR plant active power | IBR plant reactive power |
|-------------|------------------------------|--------------|------------------------|--------------------------|
| BHVRT#1 | 1.20 | 1.00 | ICR | 0 |

Frequency response capability and performance tests (EMT and PDT) for IBR plants without active power absorption capability - Table 49/D4.1

| Test Number | Event | IBR plant active power | IBR plant reactive power |
|-------------|---|------------------------|--------------------------|
| FT#1 | Overfrequency Change as per Figure 45 (D4.0) | ICR | 0 |
| FT#4 | Underfrequency Change as per Figure 46 (D4.0) | ICR | 0 |

Positive-sequence voltage phase angle change ride-through tests (EMT) for IBR plants without active power absorption capability - Table 41/D4.1

| Test Number | Event | IBR plant active power | IBR plant reactive power |
|-------------|---|------------------------|--------------------------|
| PAJ#1 | RPA positive-sequence voltage angle change equal to +25° (i.e., all three phases jump together/) | ICR | 0 |
| PAJ#2 | RPA positive-sequence voltage angle change equal to -25° | ICR | 0 |

Benchmarking of IBR models between EMT and PDT domains limited to tests with balanced events.

Test Scenarios and Cases (Subset of IEEE P2800.2 D4.0)

| Scenario | IBR Unit's nameplate rating [kVA] | Number of IBRs connected to MITS | apparent power installed capacity (S_{agg}) [MVA] | active power installed capacity (P_{agg}) [MW] | IBR continuous rating (ICR) [MW] | minimum active power capability (p_{min}) [pu@ICR] | available active power (P_{avl}) [MW] <small>Note: may be at the DC side of the IBR units</small> | Dispatch / Curtailment [pu@Sagg] | actual active power ($P_{act, p}$) [MW] | Measurements [pu@Sagg] |
|-----------------------|-----------------------------------|----------------------------------|---|--|----------------------------------|--|--|----------------------------------|---|------------------------|
| P2800.2 Pact = ICR | 1 MVA | 211 | 211 MVA | 200 MW | 200 MW | 0.01 * ICR | 1.0 * ICR | 0.95 pu (200 MW) | 1.0 * ICR (200 MW) | P_IBR = 0.95 pu |

Frequency response capability and performance tests (EMT and PDT) for IBR plants without active power absorption capability - Table 49/D4.1

| Test Number | Event | IBR plant active power | IBR plant reactive power |
|-------------|---|------------------------|--------------------------|
| FT#1 | Overfrequency Change as per Figure 45 (D4.0) | ICR | 0 |
| FT#4 | Underfrequency Change as per Figure 46 (D4.0) | ICR | 0 |

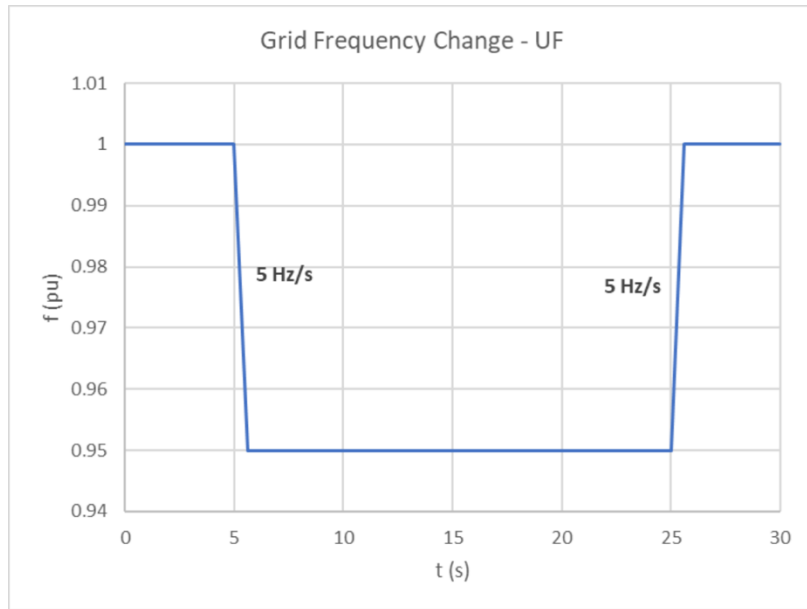

Source: © IEEE (2026), used with permission

DRAFT 3.0 Figure 47— Under-frequency performance test (frequency < nominal system frequency)

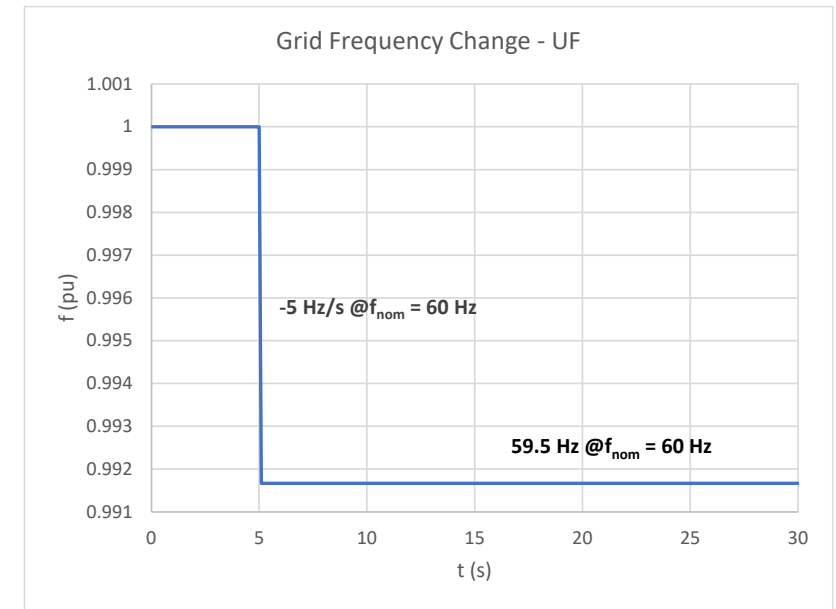

Source: © IEEE (2026), used with permission

DRAFT 4.1 Figure 48 —Example under-frequency response performance test signal and minimum simulation duration (frequency < nominal system frequency)

Assessment of GFL-IBR response to large frequency disturbances in weak grid.

Example results for former IEEE P2800.2 D3.0 frequency step tests

Preliminary results from tests based on **IEEE P2800.2 D3.0** showed that the plant model response to frequency ride-through presented some difficulties in showing conforming performance.

- SCR = 2.5
- Tests FT#1 and FT#4 applied a very large frequency step change of 0.03 pu (1.8 Hz)
- Simulations showed the **IBR plant enters LVRT mode** in response to the large disturbance, possibly due to synchronization issues with the phase-locked loops (PLLs)

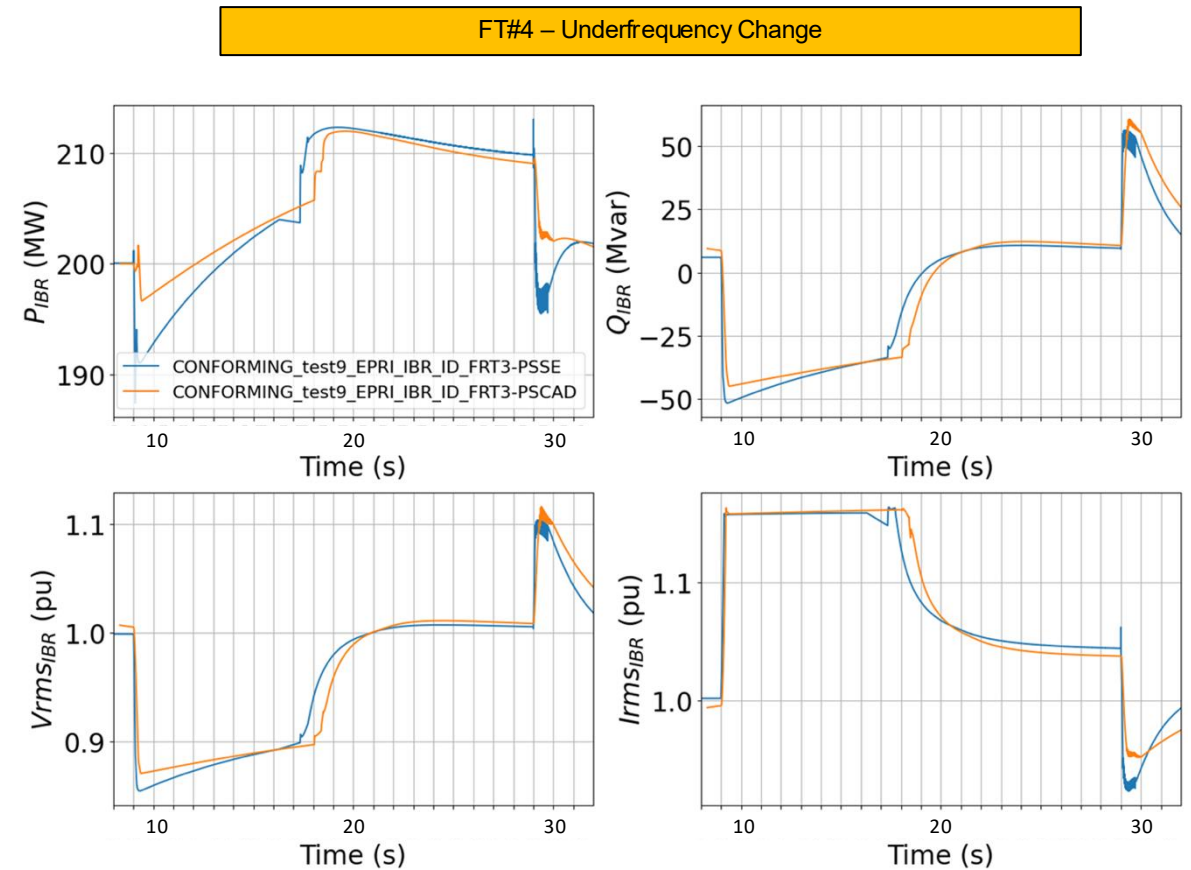

➤ Tests signals in P2800.2 Draft 4.0 should focus on small frequency response.

Example results for revised IEEE P2800.2 D4.0 frequency step tests

Tests were revised in **IEEE P2800.2 D4.0** to focus on small frequency disturbance response. Verification of frequency ride-through capability was moved into IBR plant design and OEM documentation review.

- SCR = 2.5
- Tests were revised and a frequency step change of 0.008 pu (0.5 Hz) was applied.
- Plant **does not enter LVRT**.

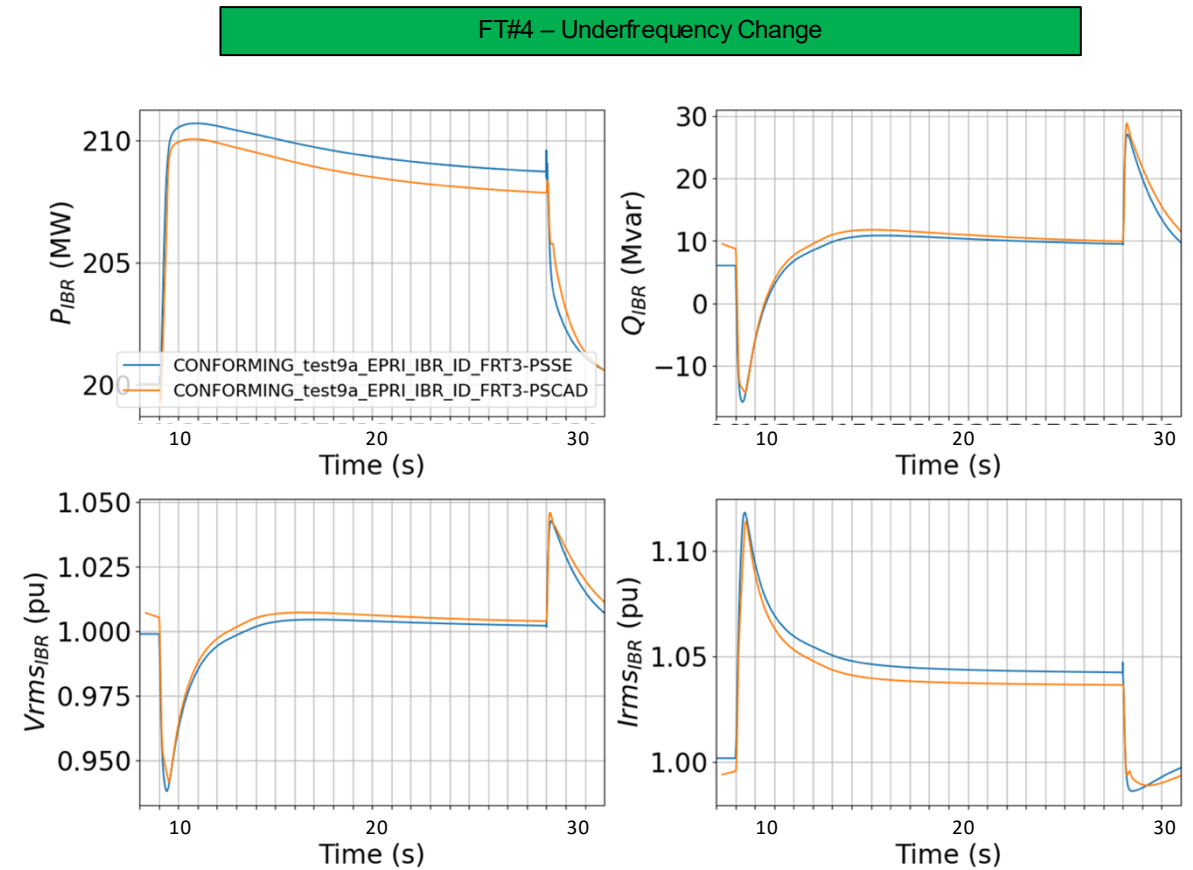

Plant reacts as expected, increasing active power to counteract UF conditions

CONFORMING PARAMETERS

P2800.2 D4.0

Summary of tests – GFL IBR Unit

| Parameter | PSCAD | kp_cur | ki_cur | TROV1_TD | HV3_PU | HV3_TD | Inv_trip | V1_frt_obs tep_flg | Kpv | Kiv | Qinit (plant) | Fixed |
|-----------|-------|-----------|-----------|----------|--------|--------|----------|-----------------------|-----|-----|------------------|-------|
| | PSSE | KPP = KPQ | KIP = KIQ | n/a | n/a | n/a | n/a | n/a | Kp | Ki | n/a | RCURR |
| Value | | 3 | 300 | 99 | 1.2 | 99 | Disabled | 0 | 0.1 | 1.0 | 0.2 | 9999 |

| Scenarios | SCR | | | | | | | |
|--|-------|------|-------|------|-------|------|-------|------|
| | 2.5 | | 3.0 | | 5.0 | | 20 | |
| | PSCAD | PSSE | PSCAD | PSSE | PSCAD | PSSE | PSCAD | PSSE |
| Voltage or reactive power control tests (EMT and PDT) for IBR plants without active power absorption capability - Table 41/D4.1 | | | | | | | | |
| VC#1 – Negative Step | OK | OK | OK | OK | OK | OK | OK | OK |
| VC#1 – Positive Step | OK | OK | OK | OK | OK | OK | OK | OK |
| Balanced low-voltage disturbance ride-through tests (EMT and PDT) for IBR plants without active power absorption capability - Table 43/D4.1 | | | | | | | | |
| BLVRT#1 | OK | OK | OK | OK | OK | OK | OK | OK |
| Balanced high-voltage disturbance ride-through tests (EMT and PDT) for IBR plants without active power absorption capability - Table 44/D4.1 | | | | | | | | |
| BHVRT#1* | OK | OK | OK | OK | OK | OK | OK | OK |
| *Balanced voltage at PPA (pu) = 1.15 pu (whereas P2800.2 D4.0 Balanced voltage at PPA (pu) = 1.0 pu) | | | | | | | | |
| Frequency response capability and performance tests (EMT and PDT) for IBR plants without active power absorption capability - Table 49/D4.1 | | | | | | | | |
| FT#1 – OF | OK | OK | OK | OK | OK | OK | OK | OK |
| FT#4 – UF | OK | OK | OK | OK | OK | OK | OK | OK |
| Positive-sequence voltage phase angle change ride-through tests (EMT) for IBR plants without active power absorption capability - Table 41/D4.1 | | | | | | | | |
| PAJ#1 | OK | OK | OK | OK | OK | OK | OK | OK |
| PAJ#2 | OK | OK | OK | OK | OK | OK | OK | OK |

Stable performance for specified parameters across different SCR levels.

Similar trends and magnitudes between EMT and PDT models.

| | | |
|---------------|---|--|
| Legend | OK (green shade) = results are acceptable, i.e., IBR response is stable and conforms with IEEE 2800 | [next action] (red shade) = results need more work, i.e., IBR response is unstable or non-conforming with 2800 |
|---------------|---|--|

CONFORMING PARAMETERS P2800.2 D4.0

Summary of tests – GFL IBR Unit

| Parameter | PSCAD | kp_cur | ki_cur | TROV1_TD | HV3_PU | HV3_TD | Inv_trip | V1_frt_db step_flg | Kpv | Kiv | Qinit (plant) | Fixed |
|-----------|-------|--------|--------|----------|--------|--------|----------|-----------------------|-----|-----|------------------|-------|
| Value | | 3 | 300 | 99 | 1.2 | 99 | Disabled | 0 | 0.1 | 1.0 | 0.2 | 1.0 |

| Scenarios | SCR | | Active power recovery to pre-disturbance level |
|---|-------|-------|--|
| | 2.5 | 3.0 | |
| | PSCAD | PSCAD | |
| Unbalanced low-voltage disturbance ride-through tests (EMT and power absorption capability - Table 45/D4.1) | | | |
| UBLVRT#1 – LL 0.00 pu @ 0.32 s | OK | OK | Current recovery to no less than 90% pre-disturbance level |
| UBLVRT#2 – LLG 0.00 pu @ 0.32 s | OK | OK | |
| UBLVRT#3 – SLG 0.00 pu @ 0.32 s | OK | OK | |
| UBLVRT#7 – LL 0.5 pu @ 3.0 s | OK | OK | IBR injects negative-sequence current dependent on IBR unit terminal (POC) negative sequence voltage |
| UBLVRT#8 – LLG 0.5 pu @ 3.0 s | OK | OK | |
| UBLVRT#9 – SLG 0.5 pu @ 3.0 s | OK | OK | |

UBLVRT#1 – Unbalanced low-voltage ride-through – line-to-line

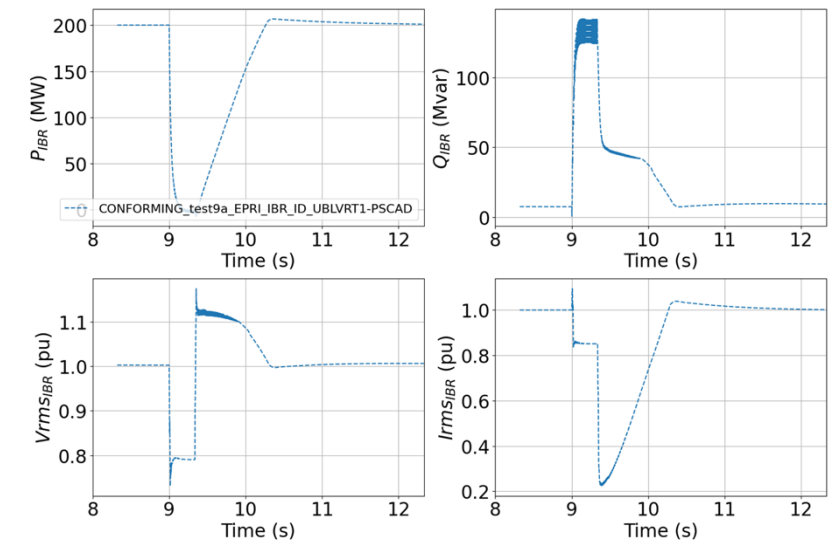

UBLVRT#1 – Unbalanced low-voltage ride-through – line-to-line

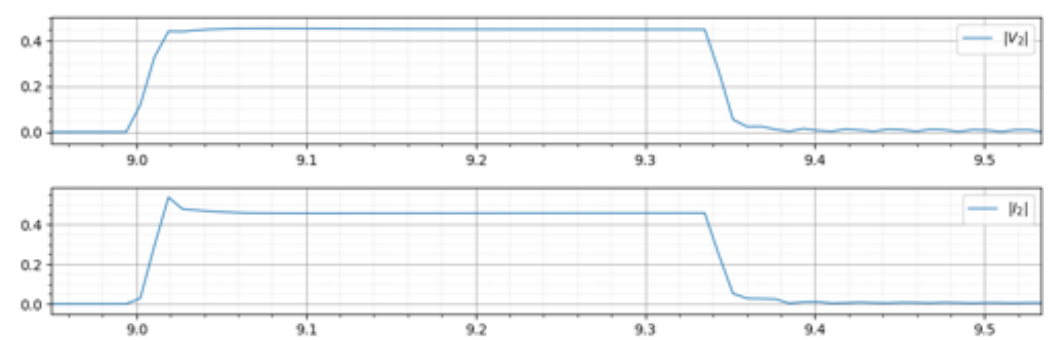

| Legend | OK (green shade) = results are acceptable, i.e., IBR response is stable and conforms with IEEE 2800 | [next action] (red shade) = results need more work, i.e., IBR response is unstable or non-conforming with 2800 |
|--------|---|--|
|--------|---|--|



**CONFORMITY TO IEEE P2800.2 TESTS
GENERIC IBR WITH ADVANCED GRID SUPPORT (GFM) MODEL**

Conformity with IEEE 2800-2022 Assessed Based on Additional Tests to IEEE P2800.2 D4.0 (10%//50% headroom)

| Voltage or reactive power control tests (EMT and PDT) for IBR plants without active power absorption capability - Table 41/D4.1 and PDT) for IBR plants without active power absorption capability - Table 41/D4.1 | | | | | |
|--|--|-----------------------|------------------------|--------------------------|--------------------------|
| Test number | Event | | | IBR plant active power | IBR plant reactive power |
| VC#1 – negative step | RPA voltage step change as per Figure 44 (D4.0) | | | ICR // 0.55*ICR | 0 |
| VC#1 – positive step | RPA voltage step change as per Figure 44 (D4.0) | | | ICR // 0.55*ICR | 0 |
| Balanced low-voltage disturbance ride-through tests (EMT and PDT) for IBR plants without active power absorption capability - Table 43/D4.1 | | | | | |
| Test Number | Fault type | Residual voltage (pu) | Duration (s) | IBR plant active power | IBR plant reactive power |
| BLVRT#1 | 3PHG | 0.00 | 0.32 | ICR // 0.55*ICR | 0 |
| BLVRT#3 | 3PHG | 0.50 | 3.00 | ICR // 0.55*ICR | 0 |
| Unbalanced low-voltage disturbance ride-through tests (EMT and PDT) for IBR plants without active power absorption capability - Table 45/D4.1 | | | | | |
| Test Number | Fault type | Residual voltage (pu) | Duration (s) | IBR plant active power | IBR plant reactive power |
| UBLVRT#1 | LL | 0.00 | 0.32 | ICR // 0.55*ICR | 0 |
| UBLVRT#2 | LLG | 0.00 | 0.32 | ICR // 0.55*ICR | 0 |
| UBLVRT#3 | SLG | 0.00 | 0.32 | ICR // 0.55*ICR | 0 |
| UBLVRT#7 | LL | 0.50 | 3.00 | ICR // 0.55*ICR | 0 |
| UBLVRT#8 | LLG | 0.50 | 3.00 | ICR // 0.55*ICR | 0 |
| UBLVRT#9 | SLG | 0.50 | 3.00 | ICR // 0.55*ICR | 0 |
| Balanced high-voltage disturbance ride-through tests (EMT and PDT) for IBR plants without active power absorption capability - Table 44/D4.1 | | | | | |
| Test Number | Balanced voltage at RPA (pu) | Duration (s) | IBR plant active power | IBR plant reactive power | |
| BHVRT#1 | 1.20 | 1.00 | ICR // 0.55*ICR | 0 | |
| Frequency response capability and performance tests (EMT and PDT) for IBR plants without active power absorption capability - Table 49/D4.1 | | | | | |
| Test Number | Event | | | IBR plant active power | IBR plant reactive power |
| FT#1 | Overfrequency Change as per Figure 45 (D4.0) | | | ICR // 0.55*ICR | 0 |
| FT#4 | Underfrequency Change as per Figure 46 (D4.0) | | | ICR // 0.55*ICR | 0 |
| Positive-sequence voltage phase angle change ride-through tests (EMT) for IBR plants without active power absorption capability - Table 41/D4.1 | | | | | |
| Test Number | Event | | | IBR plant active power | IBR plant reactive power |
| PAJ#1 | RPA positive-sequence voltage angle change equal to +25° (i.e., all three phases jump together/) | | | ICR // 0.55*ICR | 0 |
| PAJ#2 | RPA positive-sequence voltage angle change equal to -25° | | | ICR // 0.55*ICR | 0 |

Summary of Test Results

Conformity Assessment Example

| Parameter\Set | Setup |
|---------------|--------------|
| Control Mode | DROOP |
| PPC added | No |

| Scenarios | SCR | | | | | | | |
|---|------------------------------|----------------------------|----------------------------|----------------------------|----------------------------|----------------------------|------------------------------|----------------------------|
| | 2.5 | | 3.0 | | 5 | | 20 | |
| | 10% headroom Pavl = ISR | 50% headroom Pavl = ISR | 10% headroom Pavl = ISR | 50% headroom Pavl = ISR | 10% headroom Pavl = ISR | 50% headroom Pavl = ISR | 10% headroom Pavl = ISR | 50% headroom Pavl = ISR |
| Voltage or reactive power control tests (EMT and PDT) for IBR plants without active power absorption capability - Table 41/D4.1 | | | | | | | | |
| VC#1 – negative step change | OK | OK | OK | OK | OK | OK | OK | OK |
| VC#1 – positive step change | OK | OK | OK | OK | OK | OK | OK | OK |
| Balanced low-voltage disturbance ride-through tests (EMT and PDT) for IBR plants without active power absorption capability - Table 43/D4.1 | | | | | | | | |
| BLVRT#1 | P goes negative during fault | OK | P goes negative | OK | P goes negative | OK | P goes negative during fault | OK |
| BLVRT#3 | OK | OK | OK | OK | OK | OK | OK | OK |
| Balanced high-voltage disturbance ride-through tests (EMT and PDT) for IBR plants without active power absorption capability - Table 44/D4.1 | | | | | | | | |
| BHVRT#1 | OK | OK | OK | OK | OK | OK | OK | OK |
| Frequency response capability and performance tests (EMT and PDT) for IBR plants without active power absorption capability - Table 49/D4.1 | | | | | | | | |
| FT#1 – OF | OK | OK | OK | OK | OK | OK | OK | OK |
| FT#4 – UF | P settles below setpoint | OK | P settles below setpoint | OK | P settles below setpoint | OK | P settles below setpoint | OK |
| Positive-sequence voltage phase angle change ride-through tests (EMT) for IBR plants without active power absorption capability - Table 41/D4.1 | | | | | | | | |
| PAJ#1 | OK | OK | OK | OK | OK | OK | Unstable post-event | OK |
| PAJ#2 | OK | OK | OK | OK | OK | OK | Unstable post-event | OK |

GFM-IBR plant conforms to UF events when operating at 50% headroom

FT#4 – Underfrequency Change – 50% Headroom

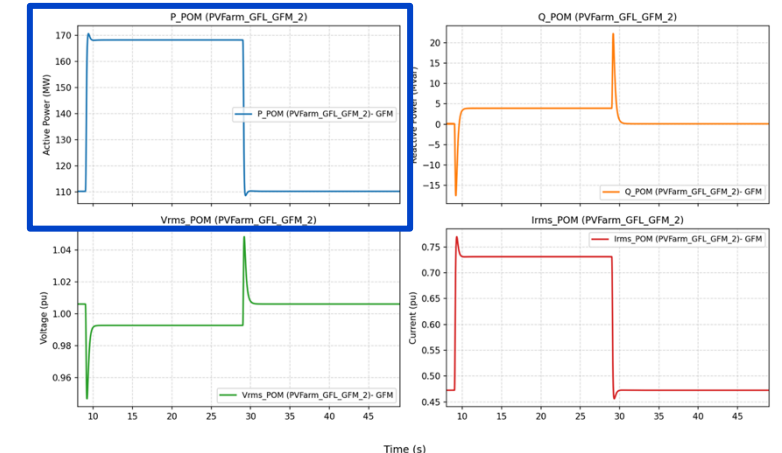

FT#4 – Underfrequency Change – 10% Headroom

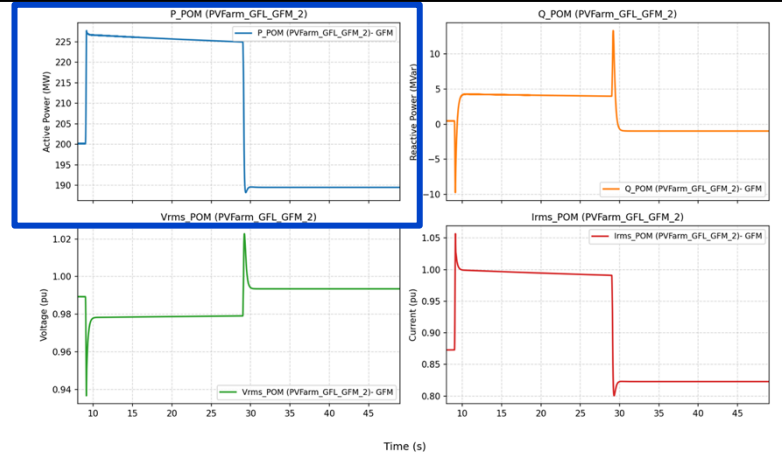

Legend OK (green shade) = results are acceptable, i.e., IBR response is stable and conforms with IEEE 2800 [next action] (red shade) = results need more work, i.e., IBR response is unstable or non-conforming with 2800

Summary of Test Results

Conformity Assessment Example

| Parameter\Set | Setup |
|---------------|--------------|
| Control Mode | DROOP |
| PPC added | Yes |

| Scenarios | SCR | | | | | | | |
|---|------------------------------|----------------------------|------------------------------|----------------------------|------------------------------|----------------------------|------------------------------|----------------------------|
| | 2.5 | | 3.0 | | 5 | | 20 | |
| | 10% headroom Pavl = ISR | 50% headroom Pavl = ISR | 10% headroom Pavl = ISR | 50% headroom Pavl = ISR | 10% headroom Pavl = ISR | 50% headroom Pavl = ISR | 10% headroom Pavl = ISR | 50% headroom Pavl = ISR |
| Voltage or reactive power control tests (EMT and PDT) for IBR plants without active power absorption capability - Table 41/D4.1 | | | | | | | | |
| VC#1 – negative step change | OK | OK | OK | OK | OK | OK | OK | OK |
| VC#1 – positive step change | OK | OK | OK | OK | OK | OK | OK | OK |
| Balanced low-voltage disturbance ride-through tests (EMT and PDT) for IBR plants without active power absorption capability - Table 43/D4.1 | | | | | | | | |
| BLVRT#1 | P goes negative during fault | OK | P goes negative during fault | OK | P goes negative during fault | OK | P goes negative during fault | OK |
| BLVRT#3 | OK | OK | OK | OK | OK | OK | OK | OK |
| Balanced high-voltage disturbance ride-through tests without active power absorption capability - Table 44/D4.1 | | | | | | | | |
| BHVRT#1 | OK | OK | OK | OK | OK | OK | OK | OK |
| Frequency response capability tests without active power absorption capability - Table 49/D4.1 | | | | | | | | |
| FT#1 – OF | OK | OK | OK | OK | OK | OK | OK | OK |
| FT#4 – UF | OK | OK | OK | OK | OK | OK | OK | OK |
| Positive-sequence voltage phase angle change ride-through tests (EMT) for IBR plants without active power absorption capability - Table 41/D4.1 | | | | | | | | |
| PAJ#1 | OK | OK | OK | OK | Unstable throughout event | Unstable post event | OK | OK |
| PAJ#2 | OK | OK | OK | OK | Unstable throughout event | Unstable post event | OK | OK |

Suggests a power plant controller (PPC) improves the underfrequency response

Angle phase jump tests showed instabilities at high SCR

FT#4 – Underfrequency Change – 50% Headroom

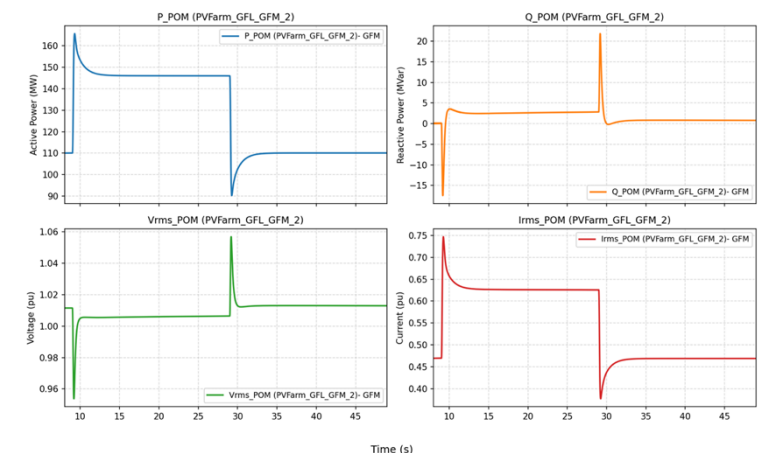

FT#4 – Underfrequency Change – 10% Headroom

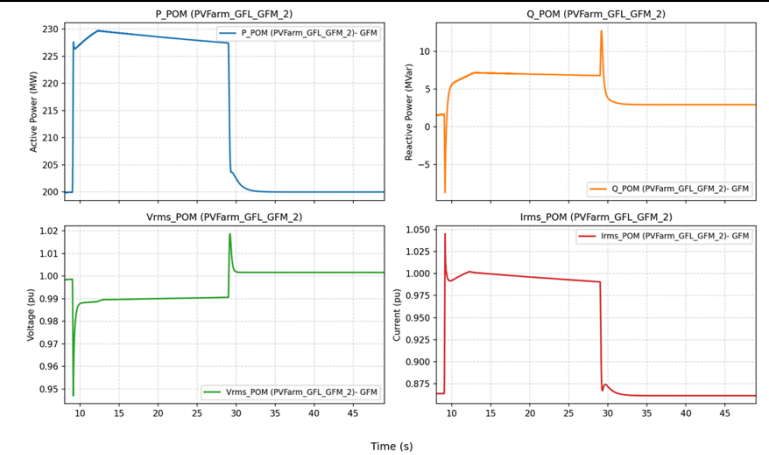

Legend OK (green shade) = results are acceptable, i.e., IBR response is stable and conforms with IEEE 2800 [next action] (red shade) = results need more work, i.e., IBR response is unstable or non-conforming with 2800



**IEEE P2800.2 Conformity Assessment
—Summary—**

IEEE P2800.2 Conformity Assessment—Summary

- This research **demonstrates a qualitative model-based IBR plant-level conforming assessment (CA)** by applying a subset of tests selected from **IEEE P2800.2 Draft 4.0** to a **generic Non-GFM plant model** in both EMT and PDT domains.
 - The **identified set** of control parameters produces IBR plant performance that conforms with **minimum requirements of IEEE 2800-2022**.
- The **phasor-domain transient (PDT) IBR models** configured with the identified parameters create the **basis for a system-wide stability study to assess the sufficiency of IEEE 2800-2022 functional capabilities and performance specifications**,
 - ☞ in a bulk power system (BPS) with high IBR-to-load penetration and
 - ☞ in which IBR plants are connected to locations where grid strength ranges from SCR values of 2.5 to 20.
- This research **also demonstrates a qualitative model-based IBR plant-level CA** for a **generic GFM-IBR plant model** in EMT domain.
 - Results show the **importance of operating GFM-IBR plants with sufficient headroom** to respond to disturbances with the desired performance.
 - **With** an adequately parameterized **power plant controller (PPC)**, operating the generic GFM-IBR plant with **10% headroom** may suffice to **conform with IEEE 2800-2022 frequency response requirements**.
 - However, for balanced and unbalanced faults **non-conformity** was observed for the **generic GFM-IBR plant model** when **operating with only 10% headroom** because its **active power response becomes negative** during these faults.



Update on IEEE P2800/.x PARs

Evolving IBR Capabilities & Grid Needs

Ongoing research and learnings will have to show ...

... e.g., how close IEEE 2800-2022 requirements are to "GFM"

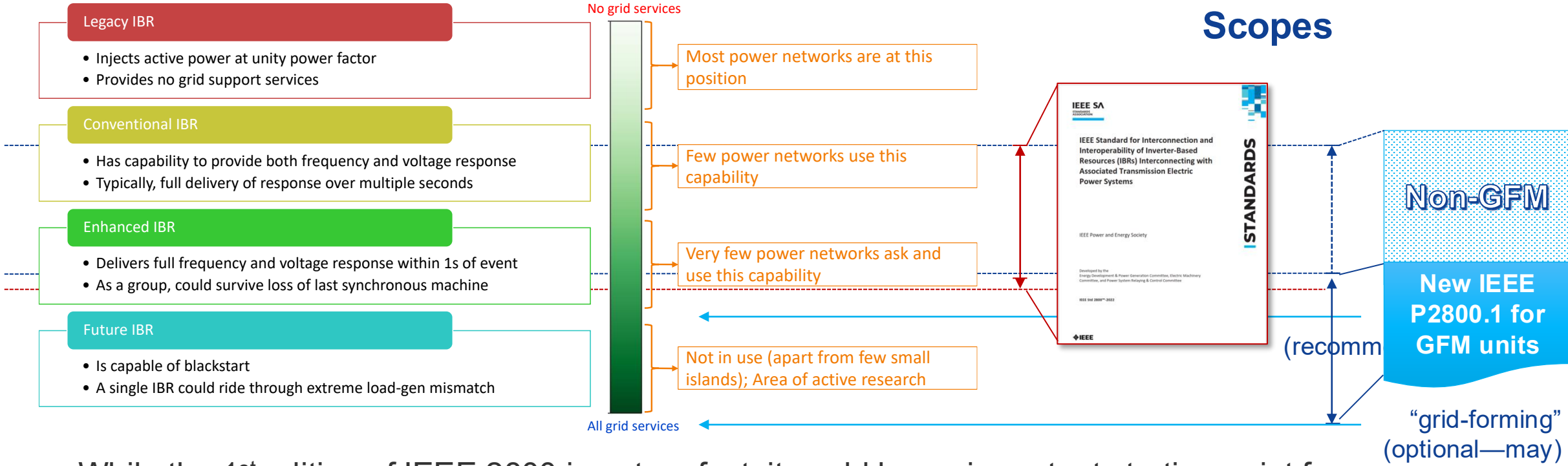

- While the 1st edition of IEEE 2800 is not perfect, it could be an important starting point for codification of collaborative industry learning and harmonization related to grid-forming technology.

As industry learns together, Standards may be revised and new standards may be created.

3x New IEEE 2800/.x Projects Aligned under one IBR-Interconnection WG

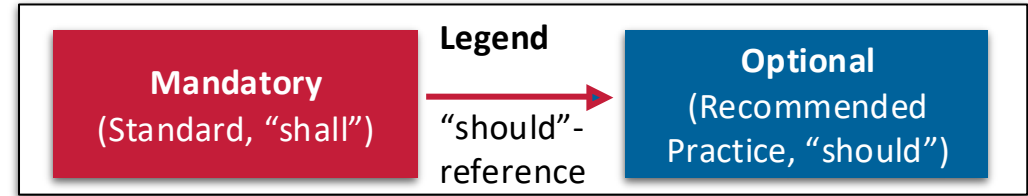

| PAR | Type | Scope | Request Date | Approval Date | Expected Date of SA Initial Ballot | Projected Date Submittal to RevCom | Publication Date | Expiration Date ¹ | Joint with IEC? |
|-------------------------------------|--------------------------|-------------------------------------|--------------|--|------------------------------------|------------------------------------|------------------|------------------------------|-----------------|
| P2800a Individual | Standard (individual) | Reduce barriers to GFM | Sep 12, 2025 | Dec 2025 <input checked="" type="checkbox"/> | Q4 2026 | Q2 2027 | April 2028 | September 2029 | No |
| P2800.1 Individual | Rec. Pract. (individual) | Framework for GFM-IBR equipment | Sep 12, 2025 | Dec 2025 <input checked="" type="checkbox"/> | Q4 2026 | Q2 2027 | April 2028 | September 2029 | Yes |
| P2800 R1 Individual | Standard (individual) | Incorporation of industry learnings | Sep 12, 2025 | Dec 2025 <input checked="" type="checkbox"/> | March 2028 | December 2028 | April 2029 | September 2029 | No |

¹ Date by when balloted draft must go to RevCom. Typically, four years from request date.

IEC & IEEE
GFM TF

P2800 & P2800.2
Subgroups

Normative References & Definitions

General Requirements

Reactive Power & Voltage Control

Active-power—frequency response

Response to TS abnormal conditions

Power Quality

Protection

Modeling Data & Measurement Data

Test & Verification

Frequency Scanning

Type tests

Design evaluations

Com. Test & As-built ev.

Next IBRI-WG Meeting tomorrow, Wednesday, January 21, 2026!

Scope of Sub-Groups under the IBR Interconnection Working Group (IBRI-WG)



IEEE/PES/EDPG/WSPPID-SC/IBRI-WG

Source: IBRI-WG | Last updated: 01/14/2026

Active subgroups / task forces

2800 Base Std Revision

IBRI-SG1: References, definitions (eg, GFM), general requirements, and overall document – Bob, Manish, Dave

Clauses 1, 2, 3, 4, A, B

IBRI-SG2: Reactive power & voltage control – Mahesh, Wes, Pat,

Clauses 5, L

IBRI-SG3: Active-power—frequency response & frequency ride-through – Rajat, Pramod, Brad

Clause 6, K

IBRI-SG4: Response to abnormal voltage conditions – Aboutaleb, Sid, Mike

Clauses 7, 9, D, F, I, J, M

IBRI-SG5: Power quality – Dave M, Eugen, Amir

Clauses 8, E

IBRI-SG6: Modeling, simulation, & measurement – Miguel, Yunzhi, Li

Clauses 10, 11, 12, G, H

IBRI-SG7: Frequency-domain applications – Wes, Shahil, Deepak

New Clause? Annex C

P2800.2 SGs (dormant for now)



P2800-2-SG2: Type tests

P2800-2-SG3: Design evaluations

P2800-2-SG4: Commissioning tests & as-built evaluations

P2800-2-SG5: Monitoring and post-commissioning steps

2800.2

Recommended Practice for IBR Conformity Assessment

GFM Task Force

Coordinated with IEC TC8 SC8A JWG5 Drafting Team for PWI 8A-26
Jens, Alex S., Steve, Alex B.

Legend: Requirements are...

Mandatory Standard
→ "shall"

Not Mandatory Recommended Practice
→ "should"

Additional scope to cover all 3 PARs under the IBRI-WG

IEEE/PES/EDPG/WSPPID-SC/IBRI-WG

Source: IBRI-WG | Last updated: 01/14/2026

Active subgroups / task forces

IBRI-SG1: References, definitions (eg, GFM), general requirements, and overall document – Bob, Manish, Dave

IBRI-SG2: Reactive power & voltage control – Mahesh, Wes, Pat

IBRI-SG3: Active-power—frequency response & frequency ride-through – Rajat, Pramod, Brad

IBRI-SG4: Response to abnormal voltage conditions – Aboutaleb, Sid, Mike

IBRI-SG5: Power quality – Dave M, Eugen, Amir

IBRI-SG6: Modeling, simulation, & measurement – Miguel, Yunzhi, Li

IBRI-SG7: Frequency-domain applications – Wes, Shahil, Deepak

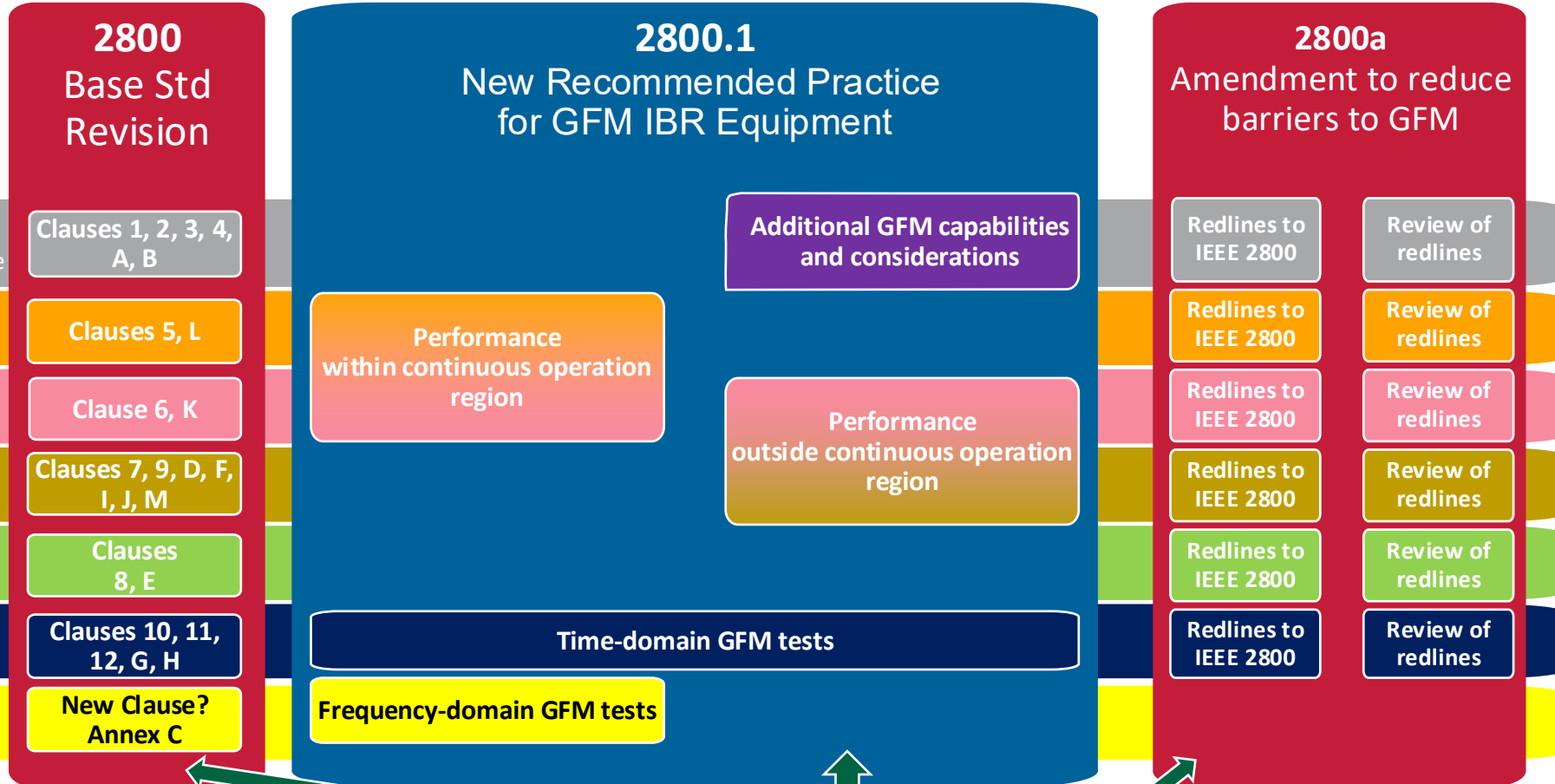

P2800.2 SGs (dormant for now)

- P2800-2-SG2: Type tests
- P2800-2-SG3: Design evaluations
- P2800-2-SG4: Commissioning tests & as-built evaluations
- P2800-2-SG5: Monitoring and post-commissioning steps

2800.2
Recommended Practice for IBR Conformity Assessment

GFM Task Force
Coordinated with IEC TC8 SC8A JWG5 Drafting Team for PWI 8A-26
Jens, Alex S., Steve, Alex B.

Legend: Requirements are...

| | |
|--|---|
| Mandatory Standard → "shall" | Not Mandatory Recommended Practice → "should" |
|--|---|

Primary responsibilities for P2800.1 content

UNIFI GFM Spec V3

Table of Contents

| | |
|---|-----------|
| Definitions | v |
| Table of Contents | vi |
| 1 Overview..... | 1 |
| 1.1 Grid-Forming (GFM) Controls..... | 2 |
| 1.2 Scope | 4 |
| 1.3 Purpose | 5 |
| 1.4 Limitations..... | 5 |
| 1.5 Constraints Due to Input Source..... | 6 |
| 2 Performance Requirements for GFM IBRs | 7 |
| 2.1 Performance Requirements for Operation Within Normal Grid Operating Conditions..... | 9 |
| 2.2 Performance Requirements for Operation Outside Normal Conditions..... | 13 |
| 3 Additional GFM Capabilities | 16 |
| 3.1 Intentional Islanding..... | 16 |
| 3.2 Black Start and System Restoration..... | 16 |
| 3.3 Regulating Voltage Harmonics | 18 |
| 3.4 Communications Between System Operator and IBR Plant..... | 18 |
| 3.5 Secondary Voltage and Frequency Signal Response | 18 |
| 4 Modeling and Documentation..... | 19 |
| 5 GFM Conformity Assessment Procedures | 20 |
| 5.1 Test Setups..... | 21 |
| 5.2 Test Reporting | 22 |
| 5.3 System Strength Test..... | 22 |
| 5.4 Unbalance Step-Up Test..... | 23 |
| 5.5 Fault Test..... | 24 |
| 5.6 Response to Frequency Change Test..... | 25 |
| 5.7 Phase Angle Jump Test | 26 |
| 5.8 Small Voltage Step Test..... | 27 |
| 5.9 Loss of Grid Connection Test..... | 28 |
| 6 Frequency-Domain Specifications | 30 |
| 6.1 Recommended Frequency Domain Specifications..... | 30 |
| 6.2 Dynamic Droop | 34 |
| 6.3 Voltage Source Behavior..... | 35 |
| References..... | 40 |
| Bibliography..... | 42 |
| Appendix A. Frequency-Domain Specifications | 43 |
| A.1 Introduction | 43 |
| A.2 Dynamic Droop Coefficients..... | 43 |
| A.3 Specifications | 46 |
| A.4 Data-Driven Conformity Verification..... | 55 |

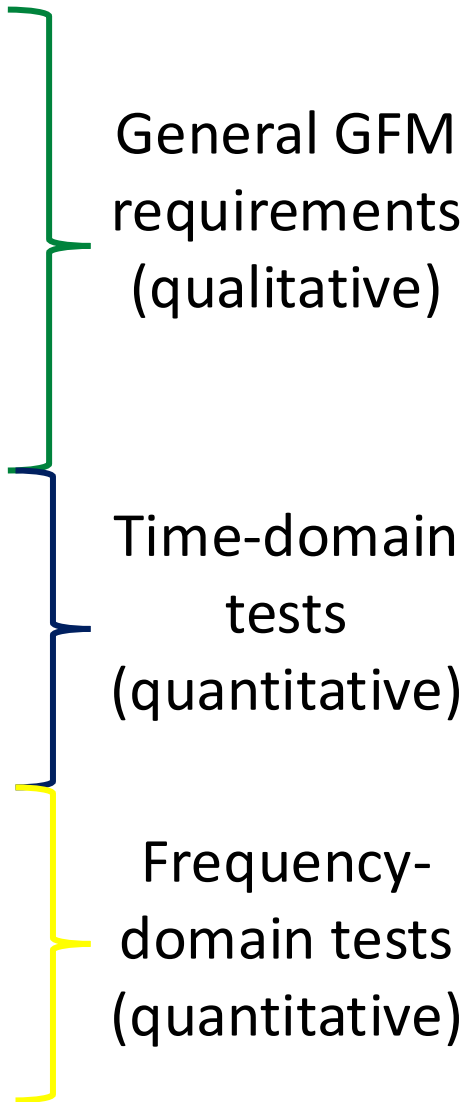

GFM Task Force
 Coordinated with IEC TC8
 SC8A JWG5 Drafting Team
 for PWI 8A-26

IBRI-SG6:
 Modeling, simulation,
 & measurement

IBRI-SG7:
 Frequency-domain
 applications

Source: Andy Hoke (NLR, formerly known as NREL)

HOW TO EXPRESS INTEREST IN IEEE MYPROJECT?

Instructions

1. On the [myProject Home Screen](#), click on “Menu” and then on “Manage Profile and Interests”
2. Click on the “Interests” tab, then on “Add Groups”
3. Find “Inverter-Based Resources Interconnection Working Group” under PES/EDPG, or simply search for “IBRI-WG” — see screenshot excerpts at right
4. Click bullet under “Groups I Am Interested In” and follow instructions on screen
5. **No IEEE SA membership required for this step.**

[Click Direct Link Here](#)

Why register on MyProject?

- Receive **WG meeting invitations**
- Receive **invitation to join IEEE-SA ballot pool** when a standard under the WG goes to ballot

Why does it not show forthcoming projects P2800a, P2800 R1, and P2800.1?

- **These projects are not authorized yet.**
- Will appear along with existing P2800.2 project, once approved by IEEE SASB NesCom later in 2025.

| Group Name | Committee | Group Type | Groups I Am Interested In |
|---|-------------------------------|----------------------|---------------------------|
| IEEE Power and Energy Society | PE | Society | |
| + Analytic Methods for Power Systems ⓘ | PE/AMPS | Standards Committee | ● |
| - Energy Development & Power Generation ⓘ | PE/EDPG | Standards Committee | ● |
| + Project Administration ⓘ | PE/EDPG/ADMIN | Working Group | ● |
| + Coordination Control of Full-Size Converter Based Variable Speed Pumped Storage Unit (FSC-VSPSU) ⓘ | PE/EDPG/CCFV | Entity Working Group | ○ |
| ... | | | |
| + Wind and Solar Plant Collector Design Working Group ⓘ | PE/EDPG/WSPPCD | Working Group | ● |
| - Wind and Solar Power Plant Interconnection and Design Subcommittee ⓘ | PE/EDPG/WSPPID | Subcommittee | ○ |
| - Inverter-Based Resources Interconnection Working Group ⓘ | PE/EDPG/WSPPID/IBRI-WG | Working Group | ● |
| + Recommended Practice for Test and Verification Procedures for Inverter-based Resources (IBRs) Interconnecting with Bulk Power Systems ⓘ | PE/EDPG/WSPPID/IBRI-WG/2800.2 | Project/Task Group | ● |
| + Wind and Solar Plant Interconnection Test and Verification Working Group (WSPI-TV) ⓘ | PE/EDPG/WSPPID/WSPi/WSPI-TV | Entity Working Group | ● |

Only needed if you are not already an IEEE P2800.2 / IBRI-WG member!

IBRI WG - SUBGROUP STRUCTURE AND MAILING LISTS

| IBRI Working Group | Andy Hoke (Chair) Manish Patel (Secretary) | STDS-IBRI@LISTSERV.IEEE.ORG | Click here to sign up for the main IBRI WG listserv |
|--|---|--|---|
| IBRI Subgroup | SG Leads | Mailing List (ListServ) | Sign-Up Link |
| SG1 – Overall document and general requirements | Manish Patel Bob Cummings Dave Narang | STDS-IBRI-SG1@LISTSERV.IEEE.ORG | Click here to sign up for SG1 listserv |
| SG2 – Reactive power and voltage control (within normal operation region) | Wes Baker Mahesh Morjaria Pat Hart | STDS-IBRI-SG2@LISTSERV.IEEE.ORG | Click here to sign up for SG2 listserv |
| SG3 – Power-frequency control and frequency ride-through | Rajat Majumder Pramod Ghimire Brad Marszalkowski | STDS-IBRI-SG3@LISTSERV.IEEE.ORG | Click here to sign up for SG3 listserv |
| SG4 – Abnormal voltage ride-through | Mike Ropp Aboutaleb Haddadi Sid Pant | STDS-IBRI-SG4@LISTSERV.IEEE.ORG | Click here to sign up for SG4 listserv |
| SG5 – Power quality | Eugen Starschich Dave Mueller Amir Kazemi | STDS-IBRI-SG5@LISTSERV.IEEE.ORG | Click here to sign up for SG5 listserv |
| SG6 – Modeling, simulation, and measurement | Miguel Duarte Campos Yunzhi Chen Li Yu | STDS-IBRI-SG6@LISTSERV.IEEE.ORG | Click here to sign up for SG6 listserv |
| SG7 – Frequency domain methods | Wes Baker Shahil Shah Deepak Ramasubramanian | STDS-IBRI-SG7@LISTSERV.IEEE.ORG | Click here to sign up for SG7 listserv |
| GFM TF – Grid-forming task force | Jens Boemer Alex Shattuck Steve Wurmlinger | STDS-IBRI-GFM TF@LISTSERV.IEEE.ORG | Click here to sign up for GFM TF listserv |

- Links will open an email in your default email app.
- Email must be sent from the address you want to subscribe.
- In the email body, fill in the placeholder for your name.



Update on related IEC standards activities

Why Coordinate with IEC?

—SWOT Analysis for a joint IEEE/IEC Project—

Strengths

- A broad set of stakeholders, including many original equipment manufacturers (OEMs)
- Leveraging of subject matter experts (SMEs) from regions with substantial practical technical and regulatory experience
- More weight for potential adoption by entities

Opportunities

- Precedence for successful joint standards like IEC/IEEE 60802 Stds, including 802.11 Wi-Fi Stds
- One step towards an International Standard (IS)
- One set of harmonized specifications
- Reduction of technical barriers for products in a global market

Weaknesses

- Additional administrative burden
- More complicated consensus building
- Potential delays

Threats

- IEC Technical Committee (TC)8 and other TCs have or are moving ahead
- Lack of coordination could create diverging sets of specifications
- If not coordinated properly, sub-par specifications could impact bulk power system reliability

Scoping and Locating a Joint IEC/IEEE GFM Standard

Informed by system (grid) needs; specify performance-based capability requirements.

Step 2

Step 3



Scope 1

Non-GFM IBRs at BPS
Plant-Level
IEC 6xxx-1-1*

Scope 3

GFM IBRs at BPS
Plant-Level
IEC 6xxx-1-2*

Scope 3

GFM IBRs
Framework for Equipment-Level
Joint IEC 6xxx-3-1* / IEEE 2800.1

- 2 Scope 1: Define IEC plant-level requirements for Non-GFM IBRs at BPS
- 1 Scope 2: Specify GFM capability and performance for IBR equipment
- 3 Scope 3: Expand IEC plant-level requirements to harmonize with IEEE
- 3 Scope 4: Specify plant-level capability to operate IBR equipment during steady state conditions to maintain GFM performance during disturbances

Step 1

Scope 2

| | | | | | |
|--|--|---|---|---|---|
| GFM PE Equipment-Level IEC 6xxx-3-2* joint with TC32 | GFM PV Equipment-Level IEC 6xxx-3-3* joint with TC32 | GFM WTG Equipment-Level IEC 6xxx-3-4* joint with TC88 | GFM ME Equipment-Level IEC 6xxx-3-5* joint with TC114 | GFM HVDC Equipment-Level IEC 6xxx-3-6* joint with TC115 | GFM BESS Equipment-Level IEC 6xxx-3-7* joint with TC120 |
|--|--|---|---|---|---|

➤ Coordinate and consider joint project(s) with IEC “to extent possible.”

How to Make It Happen?

—Established Liaison Relationships—

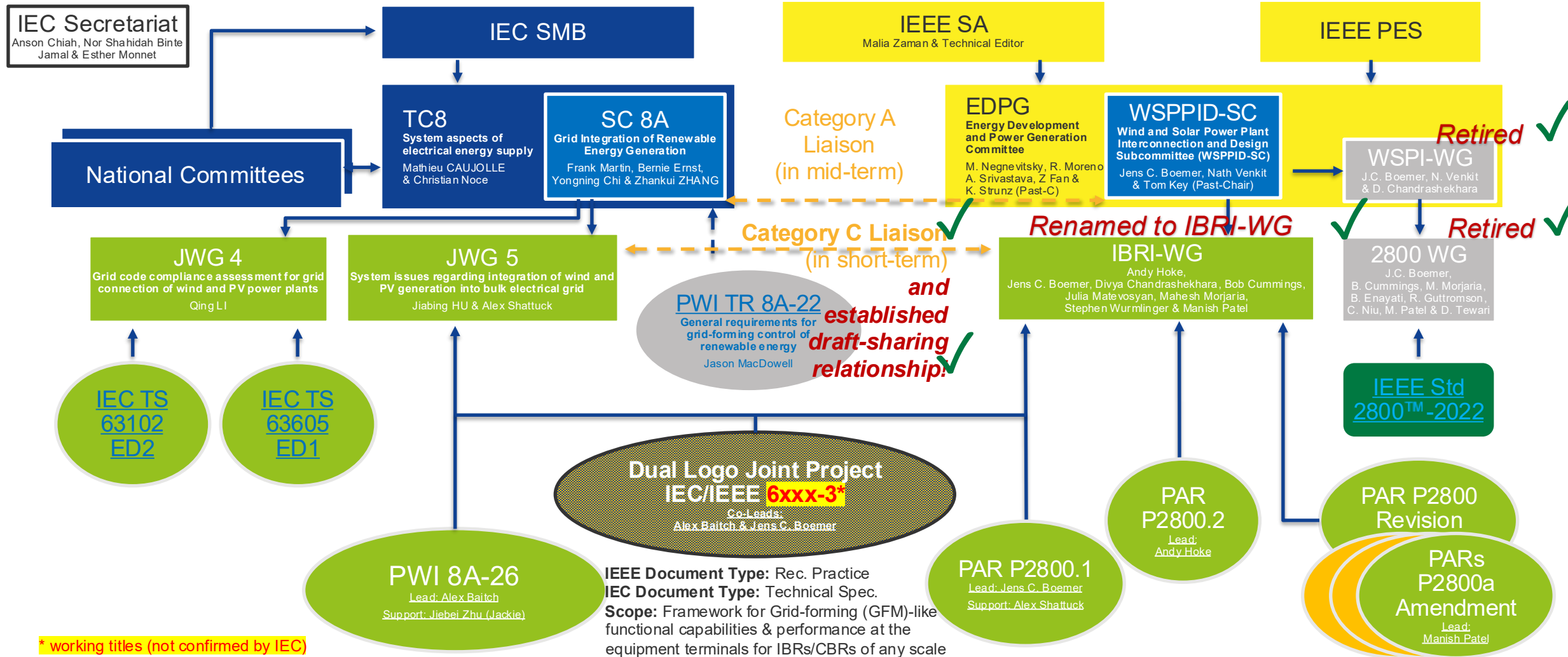

Legend:

Dormant WG or Project

Retired WG or Project

Published Document

Active WG or Project

Proposed New Project or Liaison



Update on UNIFI GFM Specifications V3 document

Who is UNIFI?

Utilities & System Operators 11

Industry 13

National Labs & Research Institutes 7

Universities 14



UNIFI Specification for Grid-forming IBRs

- Consensus-based specification for GFM IBRs
- [Version 2 published March 2024](#) along with public request for comments
- 140 comments received from 24 commenters representing 15 organizations
- Additional comments received from UNIFI members during drafting meetings
- **Version 3 finalized November 2025.** Currently awaiting DOE approval for publication. Available to UNIFI members and IEEE [IBRI WG members](#).

Summary of Comments on Version 2

140 comments from 24 commenters representing 15 organizations:



HITACHI



Notable themes:

- Clarifying IBR categories
- Frequency-domain characteristics
- System strength
- Modeling
- Test procedures
- Quantifying requirements
- Definitions
- Fault current
- Ride-through
- Uniqueness of requirements to GFM
- Power sharing

Summary of changes in V3 relative to V2

- Introduced concept of **GFM tiers**
- Main **GFM requirements are largely unchanged** and are still **qualitative**
 - Added table of requirements and test methods
 - Table states whether each requirement is unique to GFM
- Incorporated **time-domain pass-fail tests**
 - Similar to tests in use by several grid operators
 - Focused on GFM BESS
 - Inverter level, EMT
- Developed **frequency-domain tests and criteria**
 - New and highly technical content
 - Include criteria for each GFM tier
 - Inverter level, EMT
- Various other edits to address comments and clarify content
 - Added a few definitions
 - Separated requirements from informative content
 - Added reference to IEEE P2800.2 for model validation

Table of Contents

| | |
|---|-----------|
| Definitions | v |
| Table of Contents | vi |
| 1 Overview..... | 1 |
| 1.1 Grid-Forming (GFM) Controls..... | 2 |
| 1.2 Scope | 4 |
| 1.3 Purpose | 5 |
| 1.4 Limitations..... | 5 |
| 1.5 Constraints Due to Input Source..... | 6 |
| 2 Performance Requirements for GFM IBRs | 7 |
| 2.1 Performance Requirements for Operation Within Normal Grid Operating Conditions..... | 9 |
| 2.2 Performance Requirements for Operation Outside Normal Conditions..... | 13 |
| 3 Additional GFM Capabilities | 16 |
| 3.1 Intentional Islanding..... | 16 |
| 3.2 Black Start and System Restoration | 16 |
| 3.3 Regulating Voltage Harmonics | 18 |
| 3.4 Communications Between System Operator and IBR Plant..... | 18 |
| 3.5 Secondary Voltage and Frequency Signal Response | 18 |
| 4 Modeling and Documentation | 19 |
| 5 GFM Conformity Assessment Procedures | 20 |
| 5.1 Test Setups..... | 21 |
| 5.2 Test Reporting | 22 |
| 5.3 System Strength Test..... | 22 |
| 5.4 Unbalance Step-Up Test..... | 23 |
| 5.5 Fault Test..... | 24 |
| 5.6 Response to Frequency Change Test..... | 25 |
| 5.7 Phase Angle Jump Test | 26 |
| 5.8 Small Voltage Step Test | 27 |
| 5.9 Loss of Grid Connection Test..... | 28 |
| 6 Frequency-Domain Specifications | 30 |
| 6.1 Recommended Frequency Domain Specifications..... | 30 |
| 6.2 Dynamic Droop | 34 |
| 6.3 Voltage Source Behavior..... | 35 |
| SR References..... | 40 |
| B ibliography..... | 42 |
| A ppendix A. Frequency-Domain Specifications | 43 |
| A.1 Introduction | 43 |
| A.2 Dynamic Droop Coefficients..... | 43 |
| A.3 Specifications | 46 |
| A.4 Data-Driven Conformity Verification..... | 55 |

1

GFM Performance Tiers

| GFM Tier | Key Function(s) | Examples of Resource Types | Notes |
|----------|--|---|--|
| 1 | Voltage magnitude support | GFM STATCOM | |
| 2 | Tier 1 plus: Voltage angle/frequency support & minimum islanding capability | GFM E-STATCOM, GFM wind turbine (Type 3 and Type 4), GFM PV | Active power contribution is subject to complex intermittency, asymmetry, headroom, and resonance (for GFM IBRs with rotating machines) aspects. |
| 3 | Tier 2 plus: Extended islanding capability | GFM BESS | |
| 4 | Tier 3 plus black start | GFM BESS with black start | |

2 Performance Requirements for GFM IBRs

2.1 Performance Requirements Within Normal Grid Conditions

| Requirement | GFM has a unique requirement? | Could a quantitative pass-fail metric be applied? | Applicable test (Where no test is specified, a regional requirement may apply) |
|--|--|---|--|
| Autonomously Support the Grid | No | - | NA |
| Dispatchability of Power Output | No | - | NA |
| Provide Positive Damping of Voltage and Frequency Oscillations | Some GFL could comply depending on oscillation frequency | Yes | Frequency scan tests in Section 6 and Appendix A. Also spot-checked in various time-domain tests in Section 5. |
| Active and Reactive Power Sharing across Generation Resources | No | - | 5.9: Loss of Grid Connection Test |
| Operation in Grids with Low System Strength | Yes, for very weak grids | Yes | 5.3: System Strength Test |
| Operation under System Unbalance | Some GFL comply | Yes | 5.4: Unbalance Step-Up Test |

Performance Requirements for GFM IBRs

2.1 Performance Requirements Outside Normal Grid Conditions

| Requirement | GFM has a unique requirement? | Could a quantitative pass-fail metric be applied? | Applicable test (Where no test is specified, a regional requirement may apply) |
|--|---------------------------------|---|---|
| Voltage Ride-through Capability | No | Yes | Refer to relevant interconnection standard, e.g. IEEE 2800 or IEEE 1547 |
| Performance During Symmetrical Faults | Some GFL comply | Yes | 5.5: Fault Test (informative) |
| Performance During Asymmetrical Faults | Some GFL comply | Yes | 5.5: Fault Test (informative) |
| Abnormal Frequency Ride-through Capability | No | - | Refer to relevant interconnection standard, e.g. IEEE 2800 or IEEE 1547 |
| Performance in Response to Frequency Deviations | Yes, in subtransient timeframe. | Yes | 5.6: Response to Frequency Change Test |
| Performance During Phase Jumps and Voltage Steps | Yes | Yes | 5.7: Phase Angle Jump Test 5.8: Small Voltage Step Test |

3 Additional GFM Capabilities and Considerations

| Requirement | GFM has a unique requirement? | Could a quantitative pass-fail metric be applied? | Applicable test (Where no test is specified, a regional requirement may apply) |
|--|------------------------------------|---|--|
| Intentional Islanding | Yes | Yes | 5.9: Loss of Grid Connection Test |
| Black Start and System Restoration | Yes | Yes | Requirements are application-specific; no generic test provided here. |
| Regulating Voltage Harmonics | Some GFL comply at least partially | Yes | No consensus on quantitative GFM-specific requirement; no test provided here. Relevant interconnection standard applies. |
| Communications between System Operator and IBR Plant | No | - | NA |
| Secondary Voltage and Frequency Signal Response | No | - | NA |

5 Time-domain conformity assessment procedures

- Focusing on GFM BESS (aka “Tier 3 GFM”) for now
 - Some tests could be applied to other Tiers; may need modification
- Tests rely on validated **EMT model of IBR unit**.
 - Could also be run as hardware tests, but V3 does not require hardware testing
 - Some tests may also need plant controller in model
- Inverter model and plant controller model should be validated against hardware tests
 - For example, using IEEE P2800.2 procedures
- Most tests leverage existing test procedures from industry (HECO, NERC, AEMO, MISO, ERCOT, ...)
 - E.g.
https://www.ercot.com/files/docs/2024/09/16/ERCOT%20Advanced%20Grid%20Support%20ESR%20Test%20Requirement_.pdf

System strength test (SCR step-down)

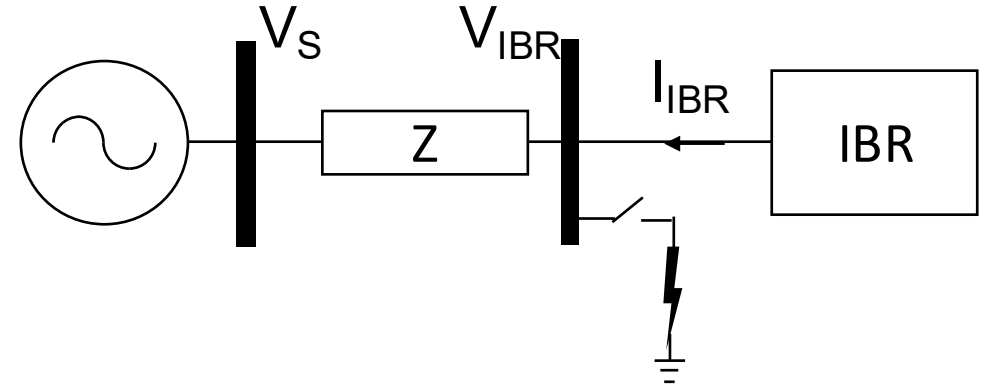

- SCR = 10; X/R = 6
- P = 1 pu; Q = 0, initially
- Step SCR down to each of the following values: 10, 5, 3, 1.5, 1.2
 - Apply 3-phase bolted 4-cycle fault just before each SCR change. SCR transition occurs at fault clearing time
 - Repeat with two-phase-to-ground, $\leq 50\%$ pos seq voltage, 6-cycle fault
- Criteria:
 - P and Q well controlled
 - Plant shall not trip nor reduce P or V below 0.95 p.u. (outside fault period) for more than 1 second at any SCR level

**Similar to
ERCOT test**

Unbalance step-up test

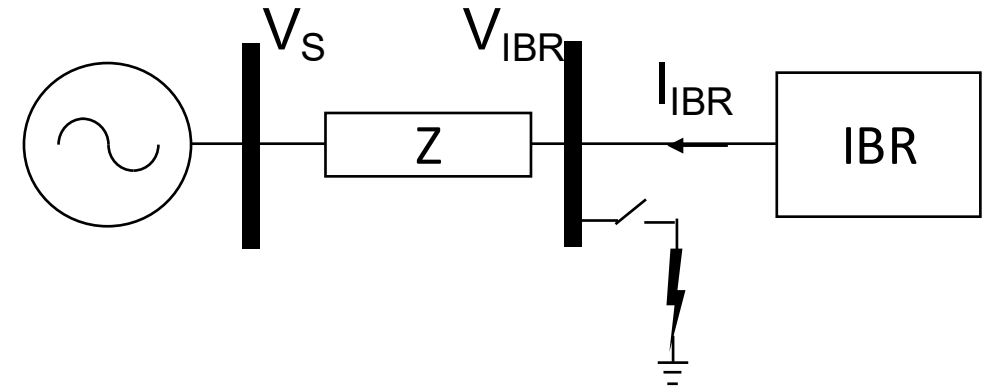

- SCR = 10; X/R = 6
- P = 1 pu; Q = 0, initially
- Step negative-sequence voltage of source up from 0 to 0.01, 0.02, 0.03, etc until IBR negative sequence current (I_2) stops changing.
 - Allow system to reach steady state after each step
 - Repeat at P = 0.5 pu, -0.5 pu, -1 pu
- Criteria:
 - When V_{S2} is non-zero, the negative sequence voltage the IBR bus, V_{IBR2} , shall be less than V_{S2} .
 - Informative: Record V_{IBR2} and I_{IBR2} at each step.

**Not in other
industry tests**

Fault test (informative)

- SCR = 10; X/R = 6
- P per table; Q = 0, initially
- Apply fault shown in table for 6 cycles. Allow transient to subside.
 - Repeat for each line in table
- Criteria:
 - No pass-fail criteria are provided
 - Informative: For tests 1-4, record P, Q, and V_{IBR} . For tests 5-8, record IBR pos and neg seq current magnitudes and angles as well as V_{IBR1} and V_{IBR2} .

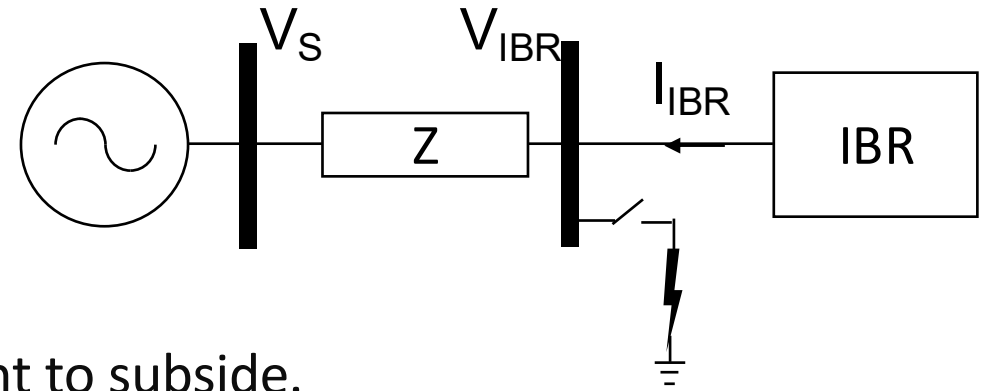

Not in other industry tests

| Scenario | IBR Active Power Set Point | Fault Type | Fault Impedance |
|----------|----------------------------|-------------------|----------------------|
| 1 | 1.0 p.u. discharging | 3 phase to ground | 0.02 p.u., resistive |
| 2 | 0.5 p.u. discharging | 3 phase to ground | 0.02 p.u., resistive |
| 3 | 1.0 p.u. charging | 3 phase to ground | 0.02 p.u., resistive |
| 4 | 0.5 p.u. charging | 3 phase to ground | 0.02 p.u., resistive |
| 5 | 1.0 p.u. discharging | 2 phase to ground | 0 |
| 6 | 0.5 p.u. discharging | 2 phase to ground | 0 |
| 7 | 1.0 p.u. charging | 2 phase to ground | 0 |
| 8 | 0.5 p.u. charging | 2 phase to ground | 0 |

Frequency change and inertial response test

- SCR = 3; X/R = 6
- P = 0 pu; Q = 0, initially
- Apply frequency profile at right
- Criteria:
 - P and Q well controlled
 - V and f do not deviate from steady state levels for significant time
 - V settles to stable point when f is not ramping
 - Equivalent inertia constant, $H > 2.5$ s. $H = f_n * \Delta E$
 - P settles according to its droop and deadband settings when frequency is not ramping
 - Any oscillation shall be damped

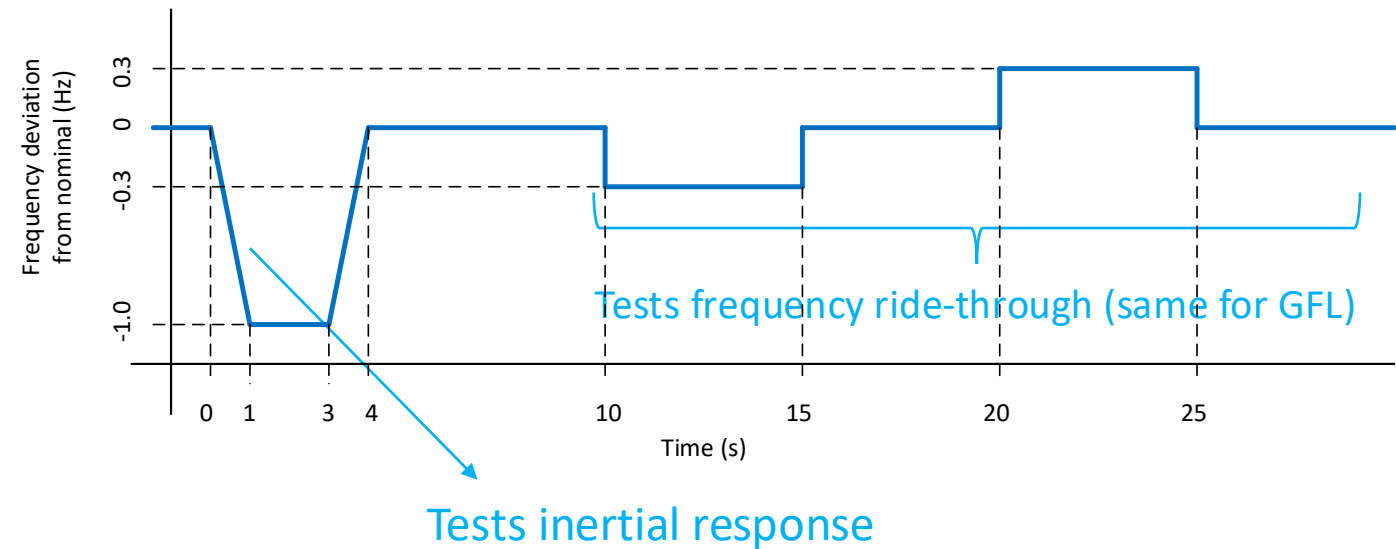

**Same as ERCOT test.
Frequency per-unitized**

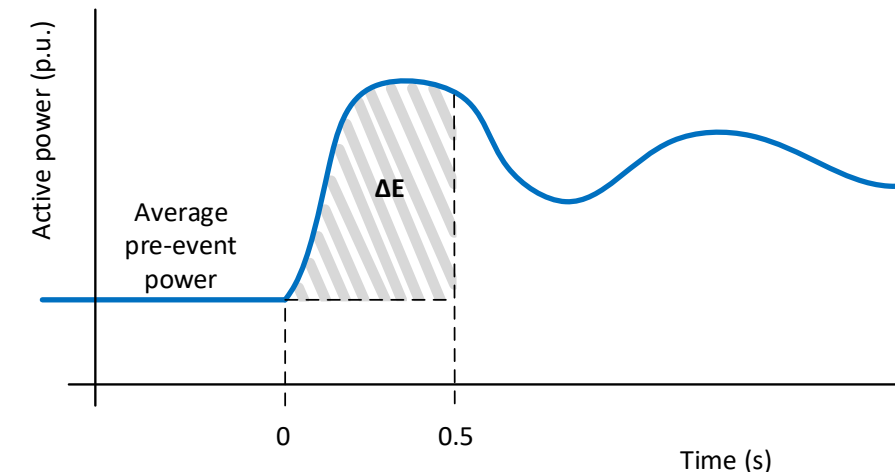

Phase angle jump test

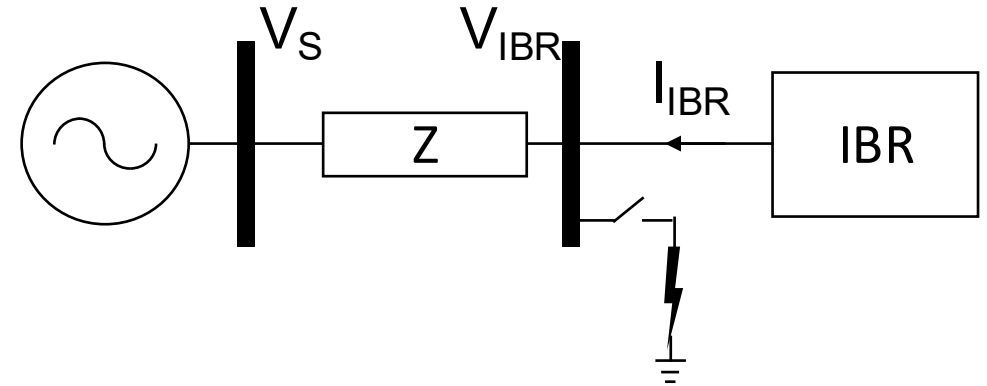

- SCR = 3; X/R = 6
- P = 1 pu, Q = 0, initially
- Step voltage source (positive sequence) phase angle down 10°, then up 10°, then up 25°, then down 25°
 - Wait a few seconds for transient to settle after each step
- Criteria:
 - For each 10° step:
 - ≥ 0.2 pu change in P (pos seq) in opposing direction
 - Can be limited by current limit
 - Response time <1 cycle to 90% of change in P
 - Any oscillation shall be damped

Basically same as ERCOT test. Clarified V and P are positive sequence.

Small voltage step test

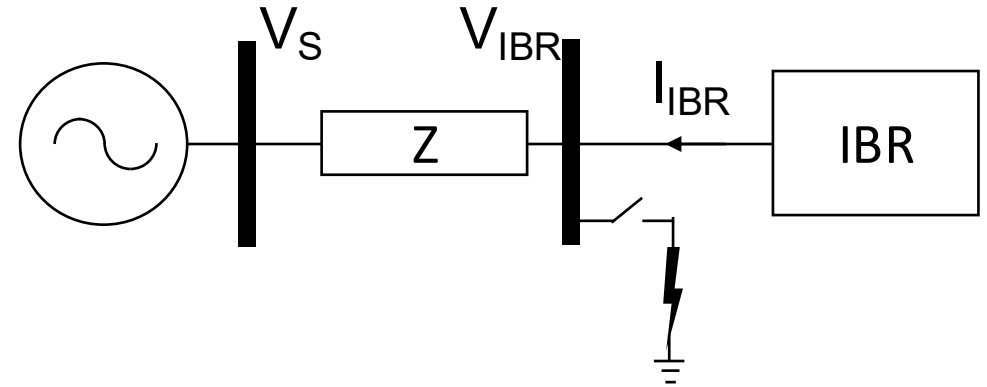

- $Z_{th} = 0$
- $P = 1$ pu, $Q = 0$, initially
- Step voltage source magnitude down 3%, then up 3%, then up 3% more, then down 3%
 - Wait a few seconds for transient to settle after each step
- Criteria:
 - For each voltage step:
 - Initial GFM response (first 6 cycles):
 - ≥ 0.03 pu change in Q in opposing direction
 - » Response time < 1 cycle to 90% of change in Q
 - Q does not return to pre-disturbance level within 6 cycles
 - Slower voltage control response (after 1st 6 cycles): Q should reach Q_{max}
 - Any oscillation shall be damped

**Started from ERCOT test.
Clarified criteria.**

Loss of grid connection

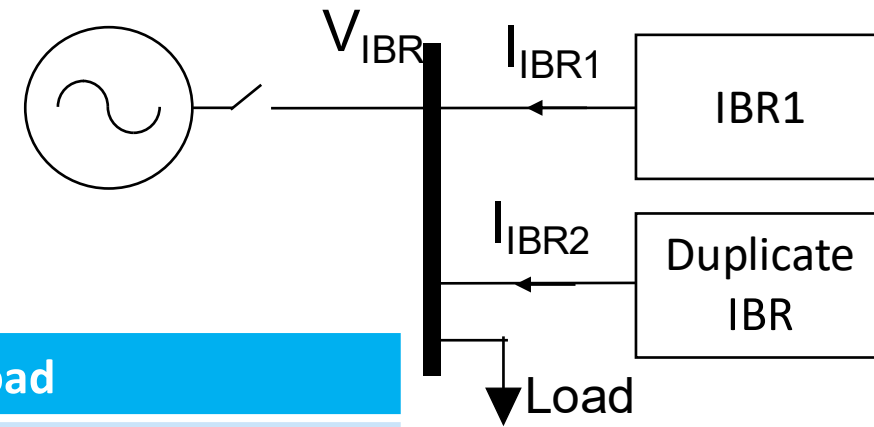

- Load pf = 0.95

| Scenario | Project BESS | Duplicate BESS | Load |
|----------------|--------------------|--------------------|---------|
| 1: discharging | 0.3 pu discharging | 0.1 pu discharging | 1.3 pu |
| 2: charging | 0.6 pu charging | 0.4 pu charging | 0.7 pu |
| 3: limit test | 0 | 1 pu discharging | 1.65 pu |

- Allow system to reach steady state, then disconnect voltage source

- Continue at least 10 seconds

- Criteria summary – see details in full document:

- P and Q well controlled

- Response time to 90% of “load deficit” within one cycle
- Settle according to droop setting

- V and f settle within 5 seconds, don’t oscillate excessively, damped within 10 seconds, and do not deviate from normal levels

- Voltage does not deviate outside [0.8 1.10] p.u. for more than 0.1 s

**Started from ERCOT test.
Clarified criteria.**

6 Frequency-domain tests

- Characterize IBR **small-signal behavior** across a range of perturbation frequencies
- Currently focused on frequencies **below 40 Hz** (subsynchronous)
 - Many SMEs feel some requirement above nominal frequency should be required, but no consensus on requirement, so no requirement included
 - Harmonic requirements that apply to all IBRs also apply to GFM
- V3 proposes applying tests to **EMT model**
 - P2800.2 says frequency scan of EMT model should closely match scan of hardware
- Frequency-domain specs are relatively new. **Need broader industry input**
- Attend IBRI WG meeting tomorrow to learn more

Transfer functions for frequency-domain specs



UNIFI Frequency Domain Specifications

Dominic Groß¹, Deepak Ramasubramanian², Dustin Howard³, Phil Hart³

Specs leverage **dynamic droop coefficients** that capture the IBR's small-signal f-P and V-Q responses:

$$\begin{bmatrix} \Delta\omega(j\omega_p) \\ \Delta V(j\omega_p) \end{bmatrix} = - \begin{bmatrix} m_p(j\omega_p) & \xi_q(j\omega_p) \\ \xi_p(j\omega_p) & m_q(j\omega_p) \end{bmatrix} \begin{bmatrix} \Delta P(j\omega_p) \\ \Delta Q(j\omega_p) \end{bmatrix} \quad (1)$$

- m_p and m_q are frequency dependent droop coefficients including magnitude and angle
- Cross-coupling terms ξ_q, ξ_p assumed to be negligible. (May not be true at frequencies above 10-20 Hz)

V3 also provides criteria based on other transfer functions that leverage GFM's **voltage-source behavior: $P/\theta, V/Q, V/I$**

- <https://www.esig.energy/gfm-performance-testing/>

V3 leaves readers to decide which of the various frequency-domain requirements to use

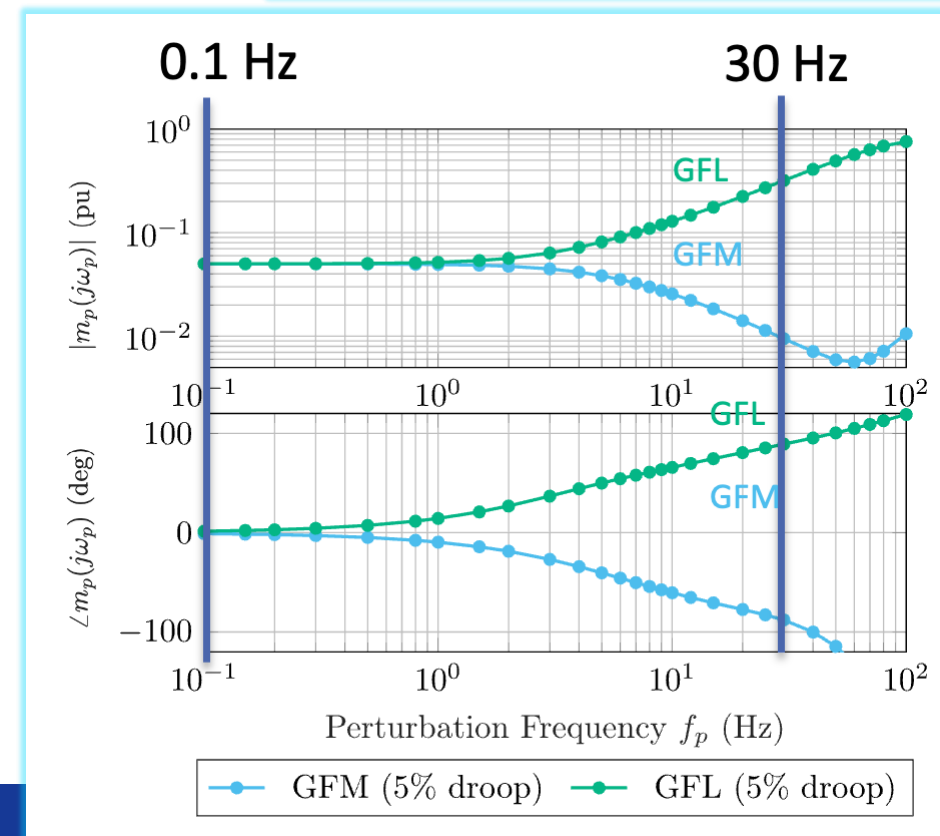

Frequency-domain requirements at *lower frequencies* (below a few Hz)

Table 5. Frequency-Domain Specifications for IBR Unit Capabilities Within the Continuous Operation Region Under Balanced Conditions—Applicable to GFM IBRs With Active Power Capability as Indicated in Last Column

| Input / Output | Capability and applicable frequency range | Specifications | | Notes | Applicable GFM Tiers |
|---|---|---|---|---|--|
| | | Frequency ω/P | Voltage V/Q | | |
| Input: P, Q Output: ω, V Sometimes called 'dynamic droop' ^a | Steady state droop $f_p \in [f_{p,\min}, f'_p]$ Approximately 0.01 Hz to 0.1 Hz, specified based on grid needs. | Upper bound on $ \omega/P $ increases [§] from $m_p(0) + 0.01$ p.u. at $f_{p,\min}$ to m''_p at f'_p with corresponding symmetric lower bound. Bound on $ \angle \omega/P $ increase [§] from 5° at $f_{p,\min}$ to $90^\circ + \epsilon_1^*$ at f'_p | Upper bound on $ V/Q $ increases [§] from $m_q(0) + 0.01$ p.u. at $f_{p,\min}$ to m''_q at f'_p with corresponding symmetric lower bound. Bound on $ \angle V/Q $ increase [§] from 5° at $f_{p,\min}$ to $90^\circ + \epsilon_1^*$ at f'_p | Frequency bounds shift towards lower values for resources with large physical inertia, or VSM with large, emulated inertia time constants, and vice versa. * <u>tolerance ϵ_1</u> to accommodate numerical/implementation aspects of control and test procedure § linear increase on log plot | V/Q : All GFM Tiers ω/P : Tier 3 and above |
| | Rate-of-change support $f_p \in [f'_p, f''_p]$ Approximately 0.1 Hz to 0.5 Hz, specified based on grid needs. | $ \omega/P \leq m''_p$ $ \angle \omega/P \leq 90^\circ + \epsilon_1^*$ | $ V/Q \leq m''_q$ $ \angle V/Q \leq 90^\circ + \epsilon_1^*$ | | V/Q : All GFM Tiers ω/P : Tier 2 and above |
| | Low frequency oscillation damping $f_p \in [f''_p, f'''_p]$ Starting from approximately 0.5 Hz with upper limit f'''_p that depends on IBR characteristics. | $ \omega/P $ below an upper bound that starts at m''_p at f''_p and decreases ten times for a ten times increase of f_p (straight line in log-log plot) $ \angle \omega/P \leq 90^\circ + \epsilon_1^*$ | $ V/Q \leq m''_q$ $ \angle V/Q \leq 90^\circ + \epsilon_1^*$ | | V/Q : All GFM Tiers ω/P : Tier 2 and above |

^a Groß, Dominic, Deepak Ramasubramanian, Benjamin Paz. December 2022. Universal input-output model of GFM functions and data-driven verification methods. UNIFI-2022-4-1.

In this frequency range, GFM is not very different from GFL

Frequency-domain requirements at *higher frequencies* (above a few Hz)

Table 6. Frequency-Domain Specifications for IBR Unit Capabilities Within the Continuous Operation Region Under Balanced Conditions—Applicable to All GFM IBRs

| Input / Output | Capability and applicable frequency range | Specifications | | | Notes | |
|---|---|--|---|---|--|---|
| | | Frequency ω/P | Voltage V/Q | | | |
| Input: P, Q Output: ω, V Sometimes called 'dynamic droop' | Power synchronization $f_p \in [f_{p,min}, f_p''']$ Starting from approximately 0.01 Hz with upper limit f_p''' that depends on IBR characteristics. | $ \omega/P $ below an upper bound that is equal to m_p'' at f_p'' and decreases ten times for a ten times increase of f_p between $f_{p,min}$ and f_p''' (straight line in log-log plot) $ \angle \omega/P \leq 90^\circ + \epsilon_1^*$ | All V/Q functions from Table 5 | | Synchronization through feedback from power to frequency without requiring steady-state droop. * <u>tolerance</u> to accommodate numerical/implementation aspects of control and test procedure | |
| | High-frequency voltage phasor stiffness $f_p \in [f_p''', 40 \text{ Hz}]$ Lower limit f_p''' that depends on IBR characteristics. | "Passive" Typical range for f_p''' is approximately 4 Hz to 10 Hz. | $ \omega/P $ below an upper bound that increases [§] ten times for ten times increase of f_p (straight line in log-log plot) $ \angle \omega/P \leq 90^\circ + \epsilon_1^*$ | $ V/Q \leq 1 \text{ p.u./p.u.}$ $ \angle V/Q \leq 90^\circ + \epsilon_1^*$ | * <u>tolerance</u> to accommodate numerical/implementation aspects of control and test procedure § starting from the gain at f_p''' | |
| | "Low gain" Typical value for f_p''' is approximately 10 Hz. | $ \omega/P \leq m_{low}$ no $ \angle \omega/P $ phase specification | $ V/Q \leq m_{low}$ no $ \angle V/Q $ phase specification | | | |
| Input: θ, V Output: P, Q Sometimes called 'power-domain scan' & Input: I Output: V Sometimes called 'impedance scan' | "Voltage source behind impedance" [7] Typical range for f_p''' consists of any values smaller than approximately 5 Hz, which provides a property like a voltage behind a reactor. One realization example recommends: $f_p''' = 4 \text{ Hz}$ | Active power P/θ | Reactive power Q/V | Impedance $Z = V/I$ | † The magnitude response of P/θ and Q/V should be almost constant over the prescribed frequency range. No index is given to check this property. * <u>permissible</u> magnitude of phase angle error. **wrapped angle within $[0, 360^\circ]$ | |
| | | Magnitude response † | | | | Equivalent inductance estimated using positive-sequence impedance, Z within $L_{min} \neq L_{max}$ frequency range, except for within $L_{min} \neq L_{max}$ |
| | | $ P/\theta > P/\theta _{min}$ | $ Q/V > Q/V _{min}$ | estimated inductance $L \leq L_{max}$ | | |
| | | Phase response | | | | |
| $ \angle P/\theta^{**} - 180^\circ < \epsilon_2^*$ | $ \angle Q/V^{**} - 180^\circ < \epsilon_2^*$ | | | | | |

This is the frequency range where GFM differentiates itself from GFL

Visualizing frequency-domain criteria – Tier 3 (GFM BESS) – option 1

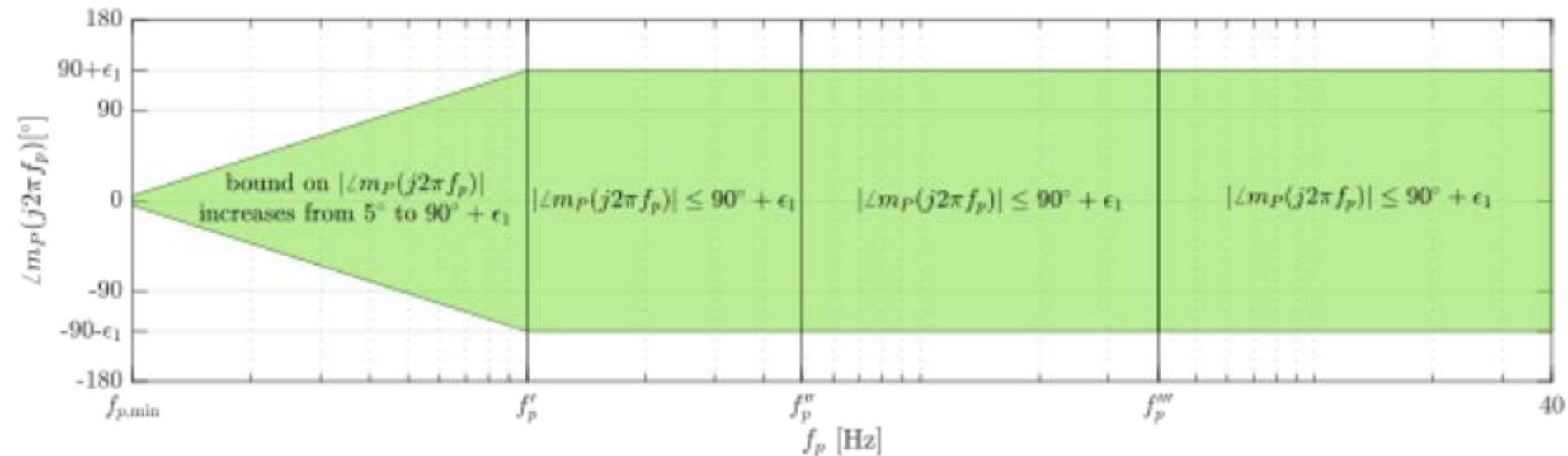
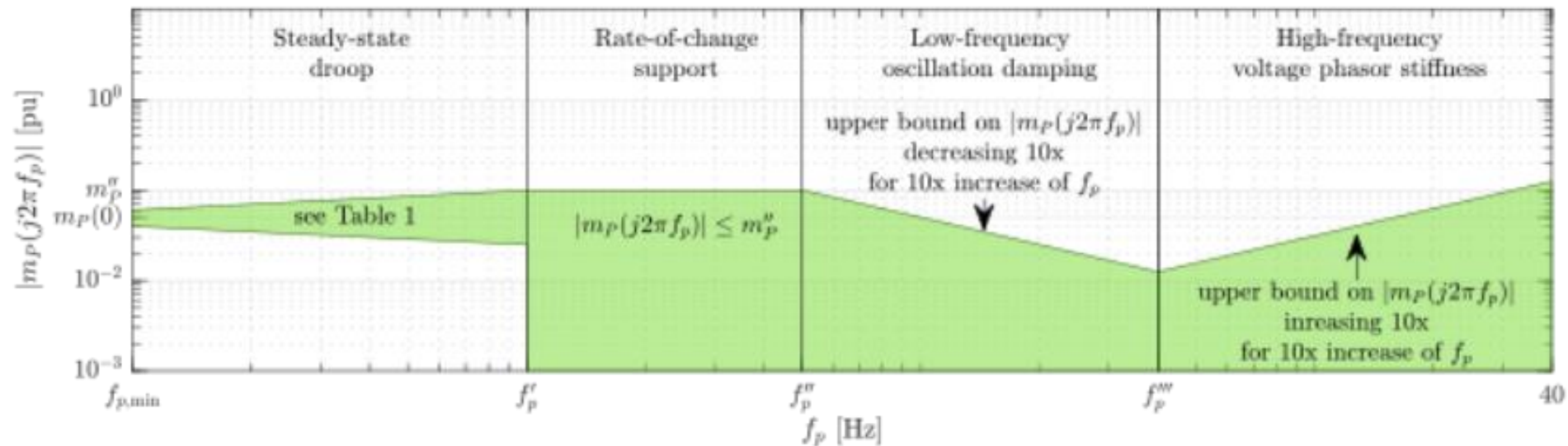

Visualizing frequency-domain criteria – Tier 3 (GFM BESS) – option 2

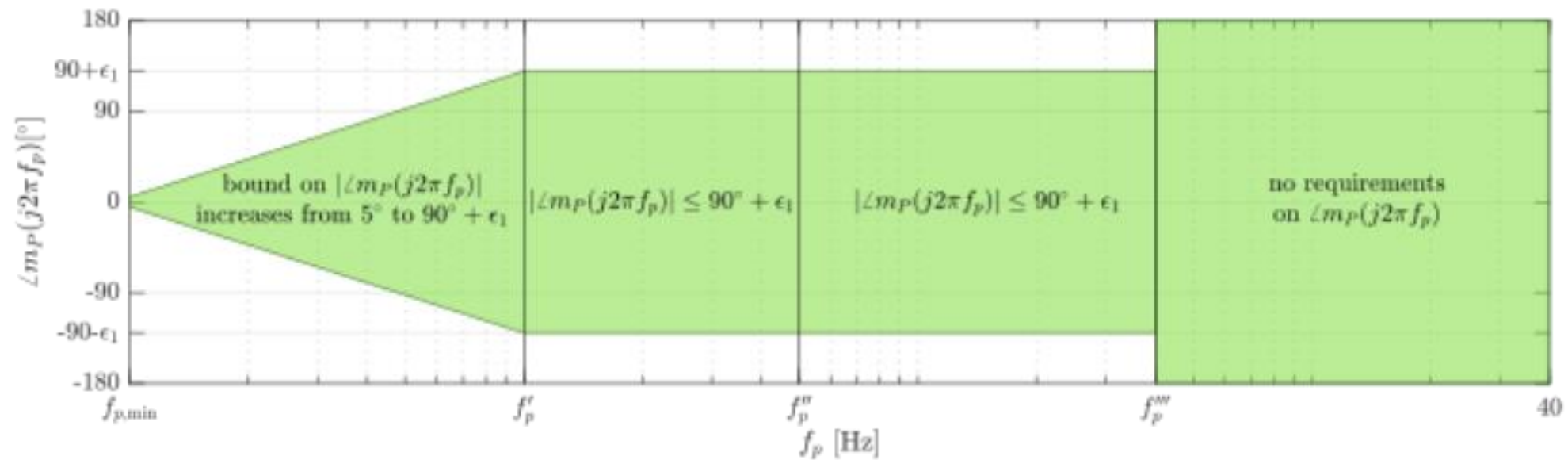
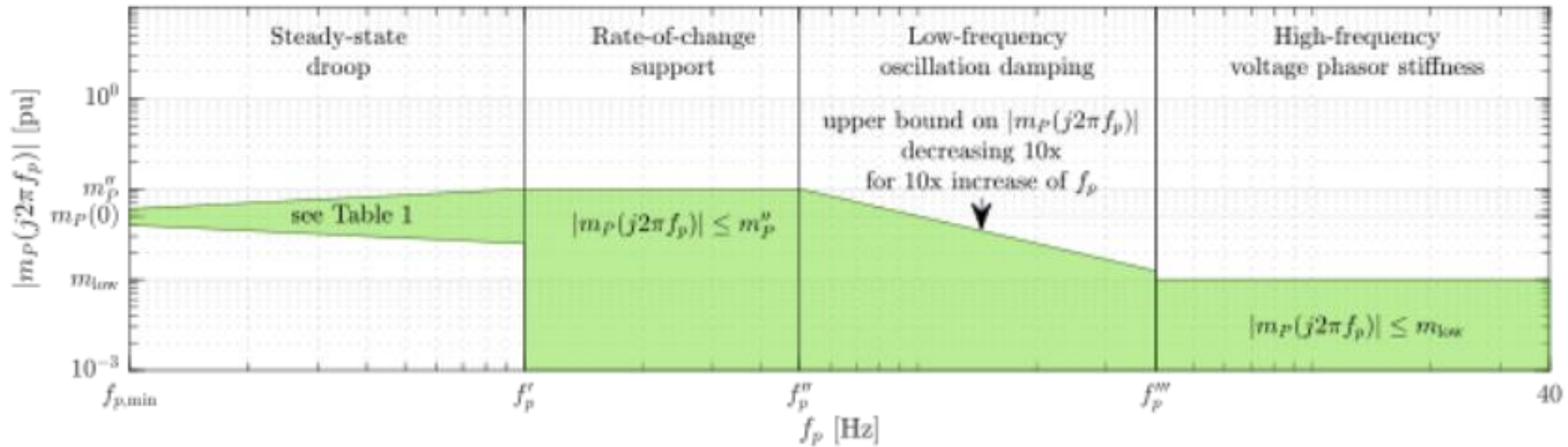



Summary & Q&A

Summary: Continuous Industry Collaboration

IEEE 2800-2022
(1st edition)

- For the time being, adopting IEEE 2800-2022 with an “**hybrid integration**” approach may be preferred because it can account for known deficiencies and gaps in the 1st edition of the standard.
 - *Future revisions should be informed by the adjustments entities made in their “hybrid integrations” —call to action for all stakeholders to get engaged in the next revision (➔ starts in 2026)*

IEEE 2800-202x
(2nd edition)

- After the forthcoming revision, a “**detailed reference & customization**” approach may be preferred because it allows for partial adoption via clause-by-clause references to the 2nd edition
 - *Not all gaps identified during the adoption of the 1st edition may be sufficiently addressed in this revision.*
 - *A detailed reference to a new **IEEE 2800.1 Recommended Practice for GFM equipment** may be included.*

+ IEEE
P2800.1
for GFM

IEEE 2800-203x
(3rd edition)

- For subsequent editions, a “**general reference**” approach **with the necessary specification of technical minimum capability** (where **options** are provided) **and functional settings** (where no default settings are provided) may be preferred, because it provides the broadest possible harmonization.
 - *Standards may be incrementally revised or amended as technology further matures.*

Keep adopting IEEE 2800-2022 and attend tomorrow’s IBRI-WG Meeting!

Related EPRI Offerings

(1) IBR CA Module – *Inverter Based Resource Conformity Assessment Module*

v1.0 (2025) forthcoming (PRE-SW, not for sale)

Need

- Ability to **assess performance of IBR plants to verify conformity** against any standards/grid codes that may be present and based on specified criteria.

Objective

- **Develop and deliver an IBR Conformity Assessment Module** that can be used to assess IBR plant response, either based on **verified plant-level models** or by use of **on-site disturbance monitoring** and field measurements.

Scope

- 1. Define **list of tests, measurements, and criteria** to be used to assess IBR plant performance and verify conformity.
 2. Develop **software modules** that can apply and carry out the conformity assessment in automated ways.
 3. Can use responses from **both generic and user defined IBR models** in **both time and frequency domain** simulations.
 4. Can use IBR measurements from on-site digital fault recording (**DFR**) and dynamic disturbance recording (**DDR**).
 5. Deliver (pre-)software

(2) Application of IBR Standards – *Collaborative Forum*

More information at: [3002032085](https://www.epri.com/3002032085)

Need

- New **IBR interconnection and reliability standards** apply to **plant owners/ developers** and will shape design and operation of IBR plants. Same standards are being adopted and enhanced by **transmission companies**.

Objective

- **Provide a collaborative forum** to exchange challenges and learnings, considering **new and existing plants**. Improve operational efficiency and **mitigate compliance risks**.

Scope

- 1. Support **interpretation** of various IBR standards (**IEEE and NERC**) and **provide conformity/compliance procedures**
 2. Provide generic IBR model parameters for existing grid-following (GFL) and advanced **grid-forming (GFM)** IBRs that conform with IEEE 2800, NERC Reliability Standards, etc.
 3. Provide application examples:
 - Use of **conformity assessment tool**
 - **Guidelines** for **utilization** of IBR capabilities
 4. Provide **thought leadership** and **facilitate development** of IBR standards

Confirmed participating funders: 6x as of 11/14/25



The image is a full-page background with a blue-to-teal gradient. In the center, a pair of hands is shown from the wrists up, holding a globe of the Earth. The globe is semi-transparent, revealing a grid of latitude and longitude lines. Overlaid on the globe is the text "Q&A" in a white, bold, sans-serif font. The background is filled with faint, glowing particles and light trails, giving it a futuristic or digital feel.

Q&A



TOGETHER...SHAPING THE FUTURE OF ENERGY®