



Oscillation Assessment Using Black-Box EMT Models of Inverter-Based Devices

Stability Challenges and MISO Strategic Plan in an IBR-Dense Grid

2026 ESIG Spring Workshop

Executive Summary

- **Grid & Stability Transformation:** The shift toward high IBR penetration and electronically interfaced loads is fundamentally evolving grid stability from traditional electro-mechanical dynamics to control- and electromagnetic-driven behavior.
- **MISO Strategic Framework:** A proactive, three-layer, risk-based roadmap for stability assessment.
- **Oscillation Assessment using EMT Blackbox:** Methodology for identifying converter-driven oscillatory risks and practical use cases.
- **Key Takeaways:** Enabling a future-ready grid by proactively identifying and mitigating emerging reliability risks.

The Changing Energy Landscape

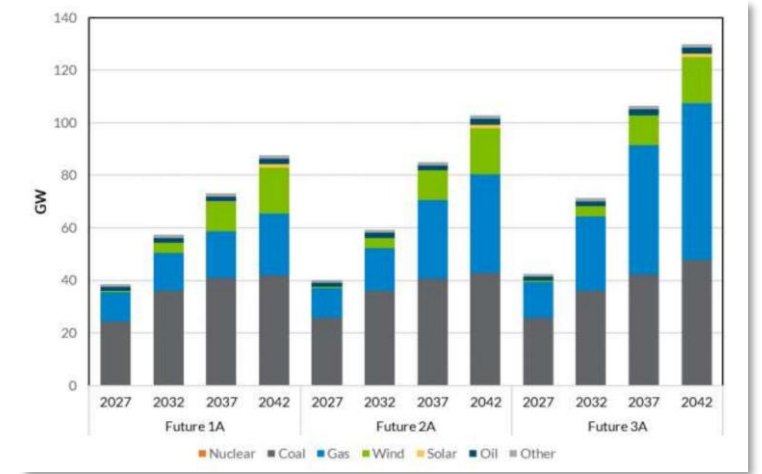
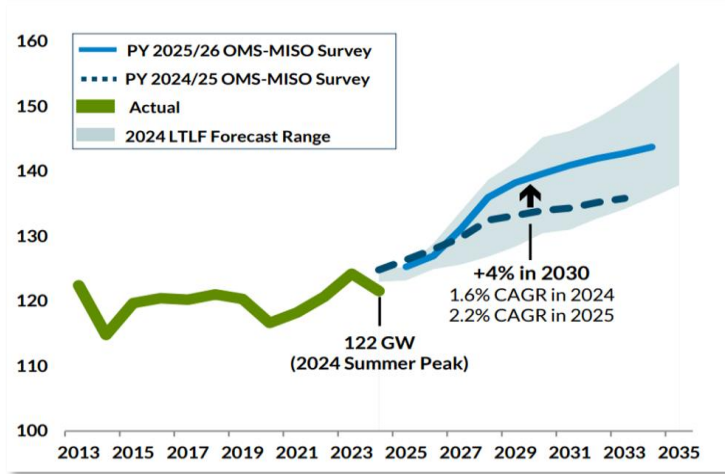
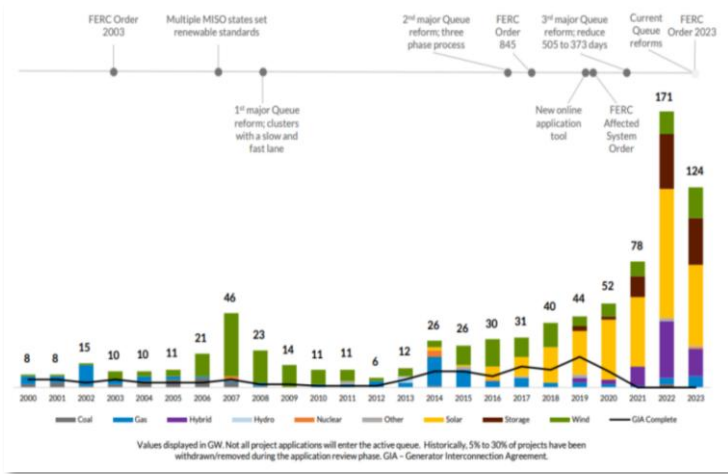

IBR penetration

IBR penetration: Exponential growth in wind, solar, and battery storage is fundamentally changing system dynamics.

Electronic loads

Rapid expansion of large data centers introduces fast-response, power-electronic interactions.





Generator retirements

Accelerating retirements of synchronous generation reduce inertia, fault current, and voltage support.





Traditional vs. Modern Power Grid Dynamics

As the grid transitions from machine-dominated to converter-dominated, stability shifts from mechanical inertia to control and electromagnetic interactions

Traditional Grid

-  **Resource Mix:** Synchronous machine-dominated generation
-  **Dominant Physics:** Electro-mechanical stability
-  **Key Dynamics:** Rotor angle, frequency, and voltage behavior
-  **Characteristic Time Scales:** Tens to hundreds of milliseconds (and seconds)

Modern Grid

-  **Resource Mix:** Power-electronic-interfaced resources and large electronic loads
-  **Dominant Physics:** Electromagnetic and control-driven stability
-  **Key Dynamics:** Fast control interactions, converter-grid coupling, resonance phenomena
-  **Characteristic Time Scales:** Microseconds to milliseconds (extending into sub-cycle dynamics)

MISO Strategic Plan - Capability Needed to Identify Emerging System Stability Risks

Emerging Converter-driven Stability Risk

What we assess:

Where the system is vulnerable to IBR tripping, ride-through failures, and large-load block tripping during disturbances



Why it matters:

Establishes our baseline risk so we can prioritize mitigation.

System Strength

What we assess:

Weak-grid conditions that amplify instability for both IBRs and large loads.



Why it matters:

Identifies where targeted engineering action is needed before new integration.

System Stability Oscillation

What we assess:

Early signs of control interactions, resonances, and converter-driven oscillations.



Why it matters:

Early detection prevents small disturbances from escalating into widespread tripping.

MISO Strategic Plan – 3 Layered Stability Strategy

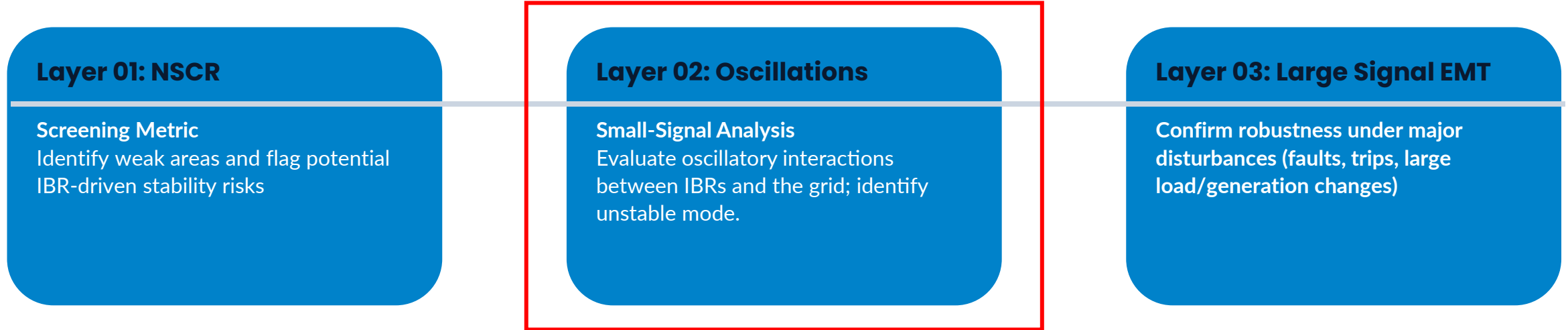

- **High IBR penetration necessitates a risk-based, multi-layer stability framework** that explicitly accounts for fast electromagnetic and control-driven phenomena.
- **Targeted analysis is essential:** not all locations or operating conditions warrant full EMT studies—system strength screening is used to prioritize and focus detailed assessment where risk is highest.
- **The strategy integrates planning, operations, and forward-looking readiness,** enabling early identification of emerging risks and proactive mitigation as the resource mix evolves.
- MISO’s layered approach enables **right-sized analysis, targeted mitigation, and reliable operation** in a high-IBR grid.

Oscillation Assessment Using Black-Box EMT Models (Small-Signal Assessment)

Operation	Planning
Operation-Point Risk Monitoring Assess oscillation risk under seasonal conditions and varying operating points.	Oscillation Risk Screening Identify regions prone to oscillatory instability, including low-frequency system and control-driven oscillations as well as fast converter-network control interactions.
Model Validation Support tuning of inverter control parameters to improve damping	Mitigation Prioritization Prioritize targeted mitigations and stability-driven reinforcements
Oscillation Awareness Inform operational procedures to avoid triggering unstable modes	Interconnection Robustness Support robust and stable converter interconnection design

Purpose / Key Idea

- Evaluate oscillatory interactions between inverter-based resources (IBRs) and the grid
- Identify poorly damped or unstable modes arising from converter-network interactions

Oscillation assessment tool extracts small-signal models from black-box EMT models of inverter-based resources and conduct small-signal stability analysis using SSAT.

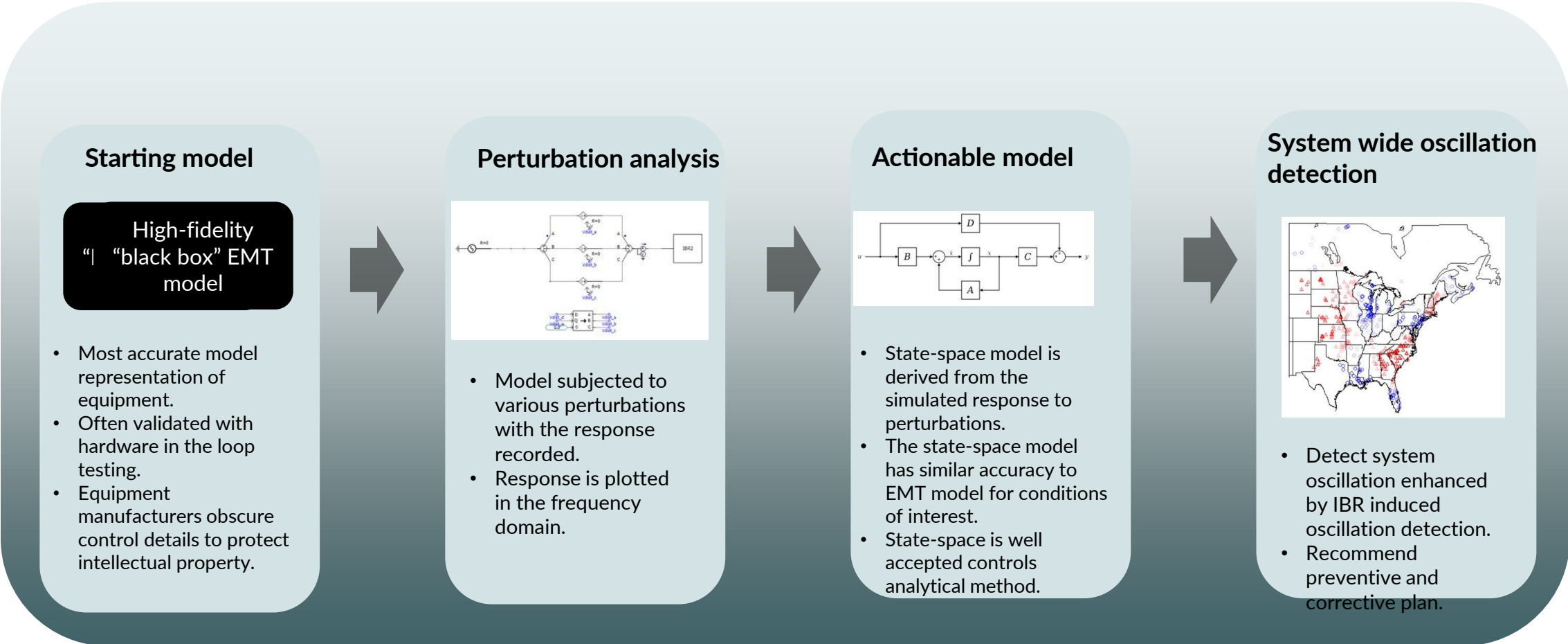

Small-signal Analysis with Black-box Models

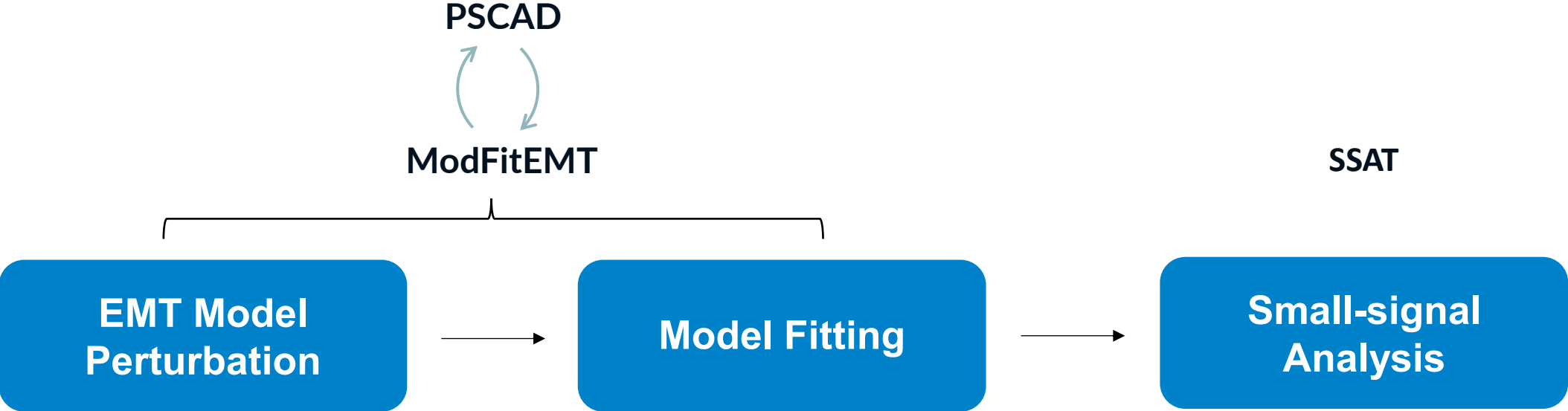

Offline:

- Scan black-box models in PSCAD
- Fit small-signal models to scan results

Online:

- Small-signal stability assessment:
 - Current conditions
 - Contingencies
 - Transfers

EMT Model Perturbation

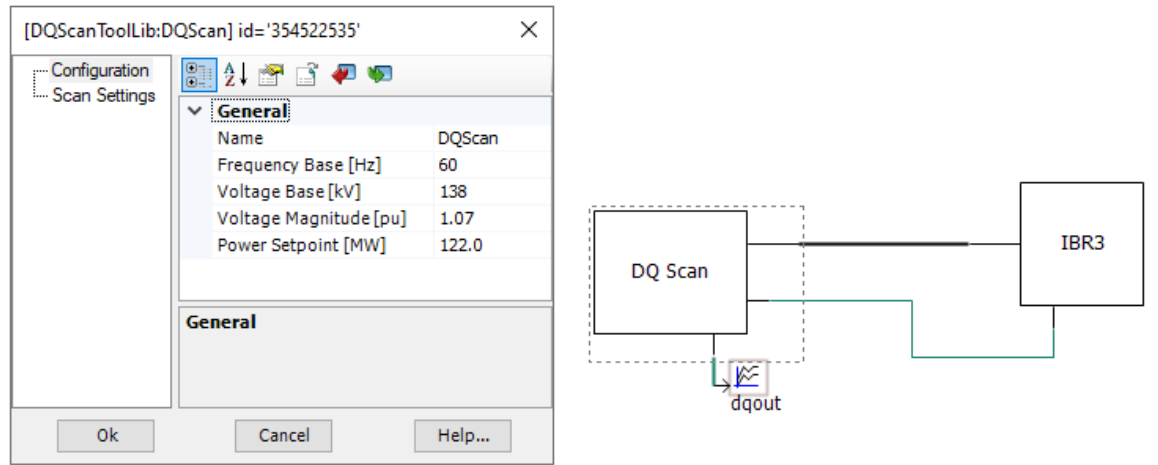

- PSCAD module applies small dq frame voltage perturbations
- Sequential sine and multi-sine perturbations are supported
- Scan can be applied to full plant (multiple IBRs + PPC) represented by black-box PSCAD models

Sequential sine

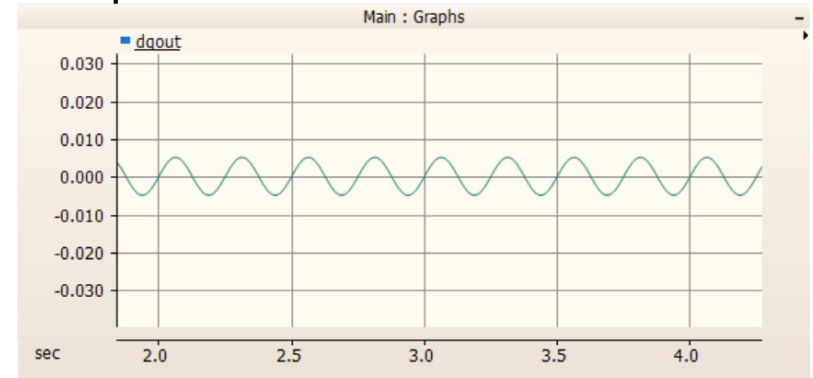

Multi-sine

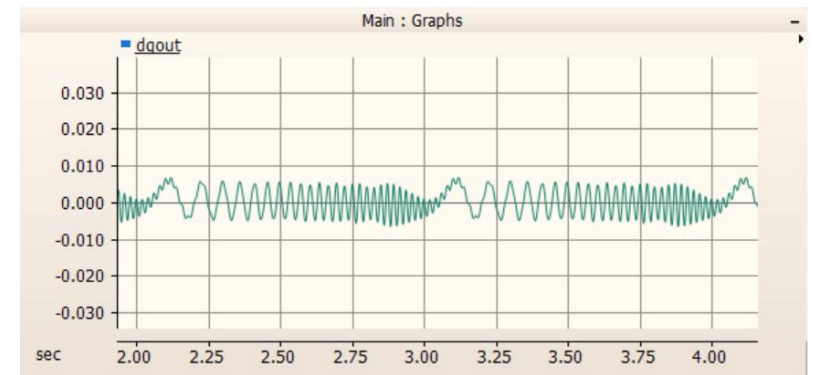

Small-signal Model Fitting

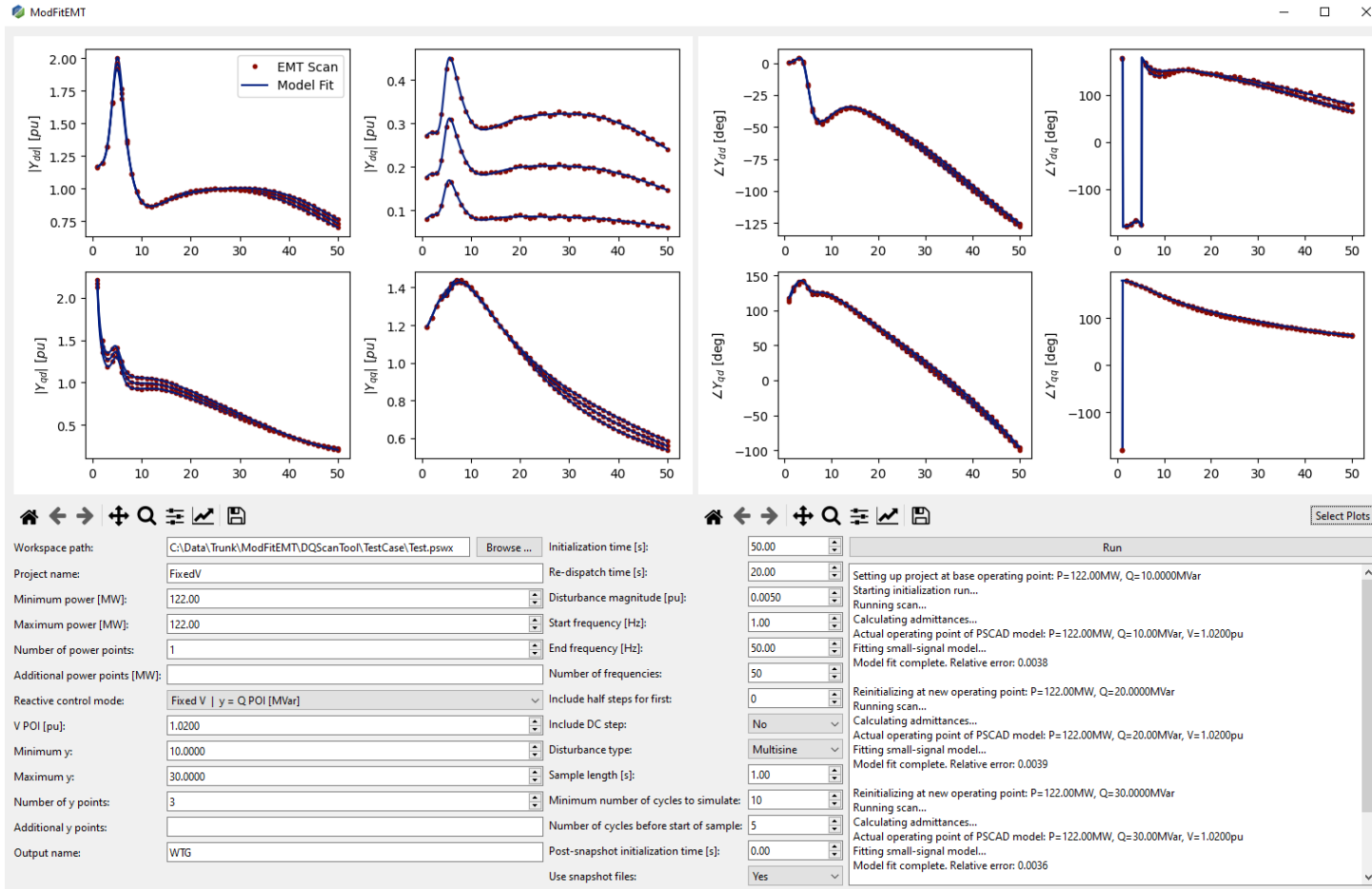

ModFitEMT is a stand-alone application to:

- Automate PSCAD model perturbation tests
- Fit a small-signal models according to perturbation results to be used in SSAT
- Model fits are created across a range of operating points to enable interpolation

dq frame admittance matrices are used to represent the dynamic response

$$Y(s) = \begin{bmatrix} Y_{dd}(s) & Y_{dq}(s) \\ Y_{qd}(s) & Y_{qq}(s) \end{bmatrix}$$

The **vector fitting algorithm** fits a small-signal model to the dq admittance response

$$Y(s) \approx \sum_{n=1}^N \frac{R_n}{s - p_n} + D$$

Application Example: Study Case

- Weak system pocket with 5 black-box PSCAD models
- Study area size:
 - PSCAD case: 240 buses
 - E-Tran+ parallelization
 - SSAT case: 713 buses
 - **SSR Mode** enabled to represent network dynamics
- 9 contingencies under study
 - Results show severe instability in base dispatch
- 6 dispatch scenarios evaluated in SSAT
 - Curtailment (multiple levels)
 - One IBR out (with / without curtailment)
 - Two IBRs out
- Only two IBRs out shows potential for secure operation
 - Other scenarios show unstable modes or PF non-convergence

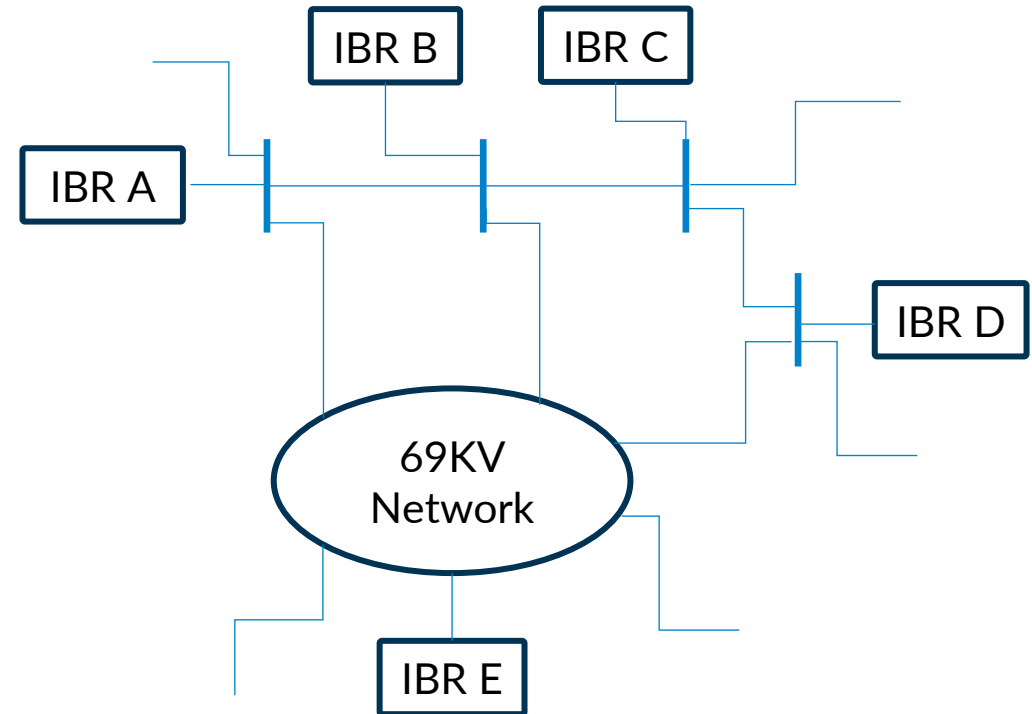

Application Example: Results

IBR A and IBR B Out Contingency 3

SSAT:

Frequency	Damping
26.26 Hz	-18.85 %

PSCAD:

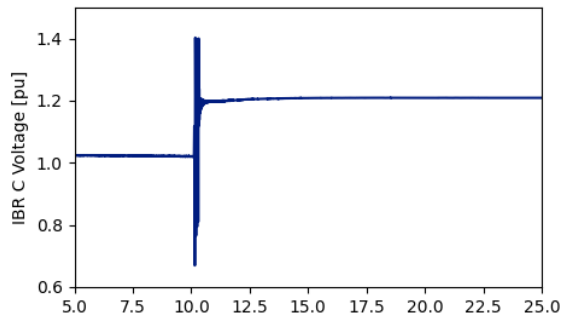

Brief 20 Hz oscillation,
then IBR C trips

IBR A and IBR B Out Contingency 5

SSAT:

Frequency	Damping
33.80 Hz	-7.81 %

PSCAD:

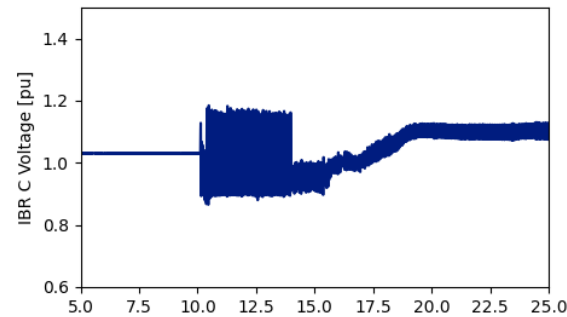

Sustained 30 Hz
oscillation

IBR B and IBR C Out Contingency 5

SSAT:

Frequency	Damping
43.67 Hz	14.21 %

PSCAD:

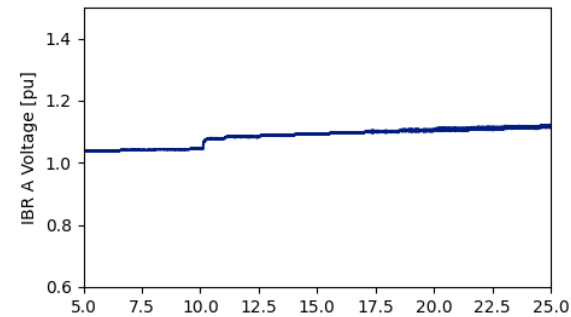

Computation Time Total

Impedance Scans: 59h28m

SSAT run (per ctg): **1.6s**

Total (6x9 ctgs): 59h30m

PSCAD run (per ctg): **3h38m**

Total (6x9 ctgs): 196h36m

Conclusion & Next Steps

- MISO recognizes evolving stability challenges with increasing IBR penetration.
- Ongoing efforts are focused on enhancing modeling, assessment methods, and risk identification.
- Collaboration with industry partners and stakeholders is key to addressing emerging risks.

Q&A / Discussion
