

Grid-Forming Control for Power System Oscillation Damping: Insights from Angle Stability before the Iberian Blackout of 2025

Prof. Dr.-Ing. Lijun Cai *University of Rostock, Germany*

ESIG Webinar April 22, 2026 11:00 am – 12:00 pm

Contents

1. General information

Affected area

System condition before the blackout

2. Power system oscillations

PMU measurements and major windows

Local oscillations

Inter-area oscillations

Countermeasures

3. Contribution of renewable generation

4. Possible control solutions

Contents

1. General information

Affected area

System condition before the blackout

2. Power system oscillations

PMU measurements and major windows

Local oscillations

Inter-area oscillations

Countermeasures

3. Contribution of renewable generation

4. Possible control solutions

Affected Area

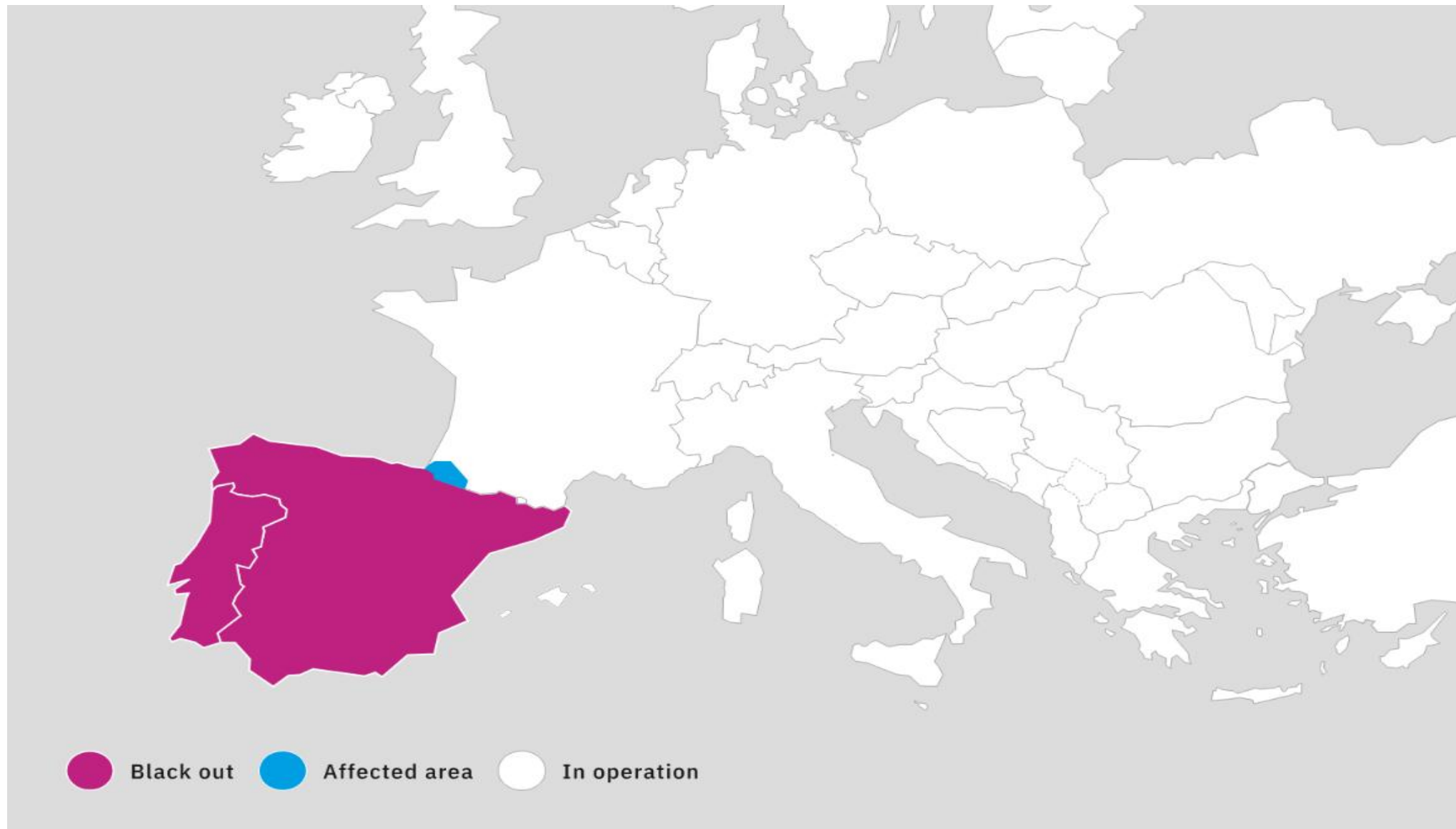

System Condition before 12:00

Voltage Fluctuations (400kV Nodes 09:00 – 12:00 CEST)

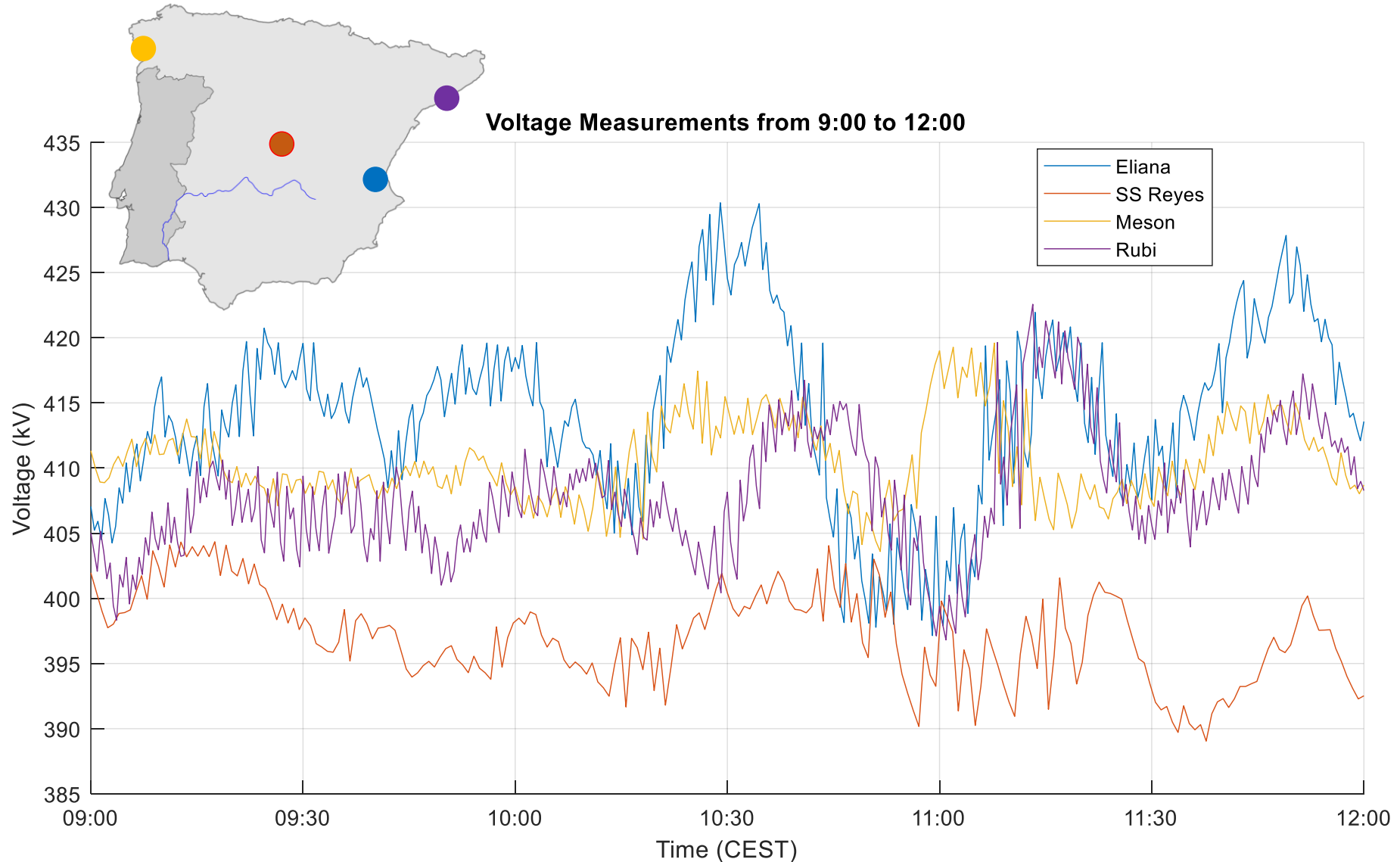

System Condition before 12:00

Voltage Fluctuations (220kV Nodes 09:00 – 12:00 CEST)

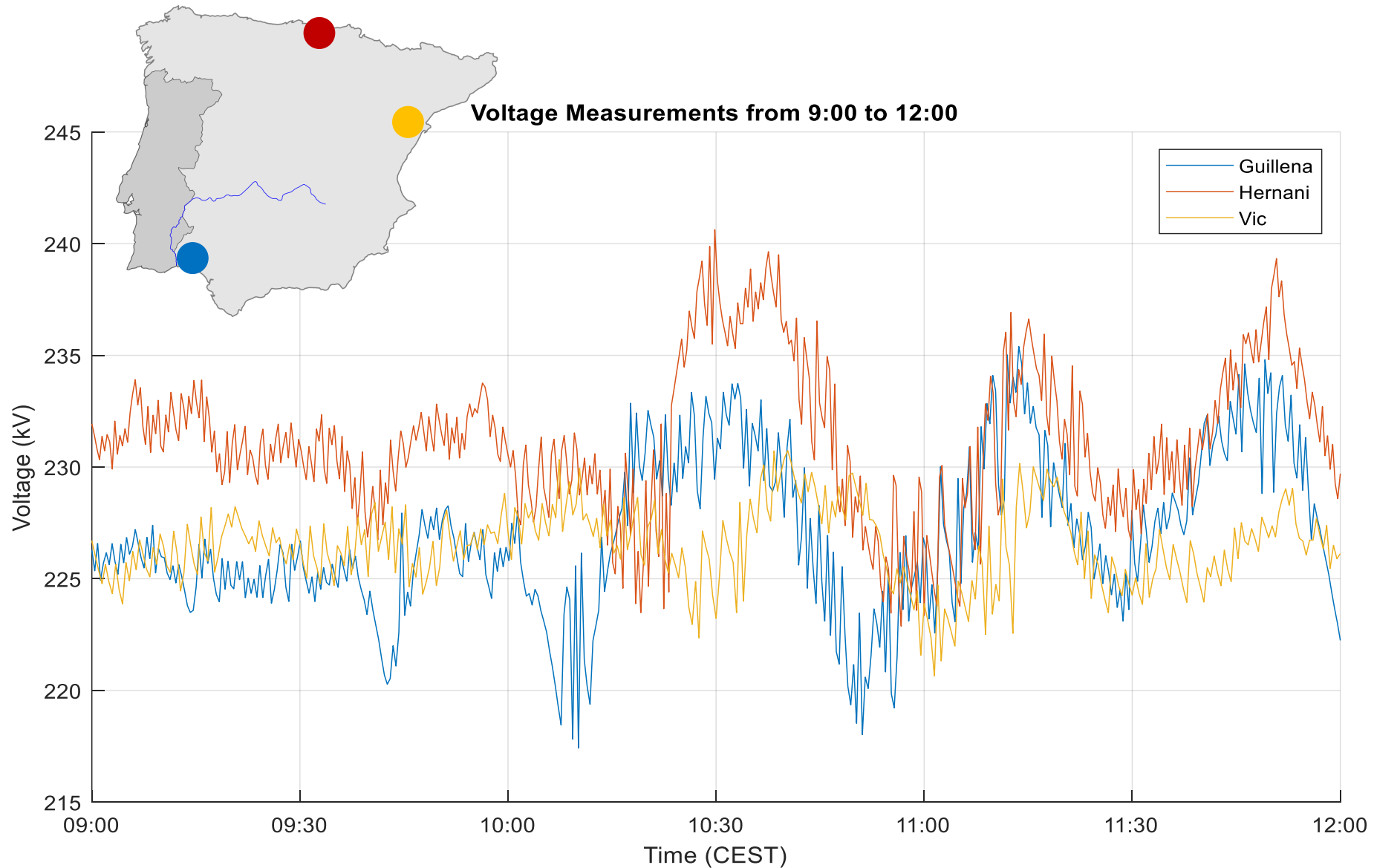

System Conditions

Heat maps of the 400kV Grid (p.u.) at 12:00

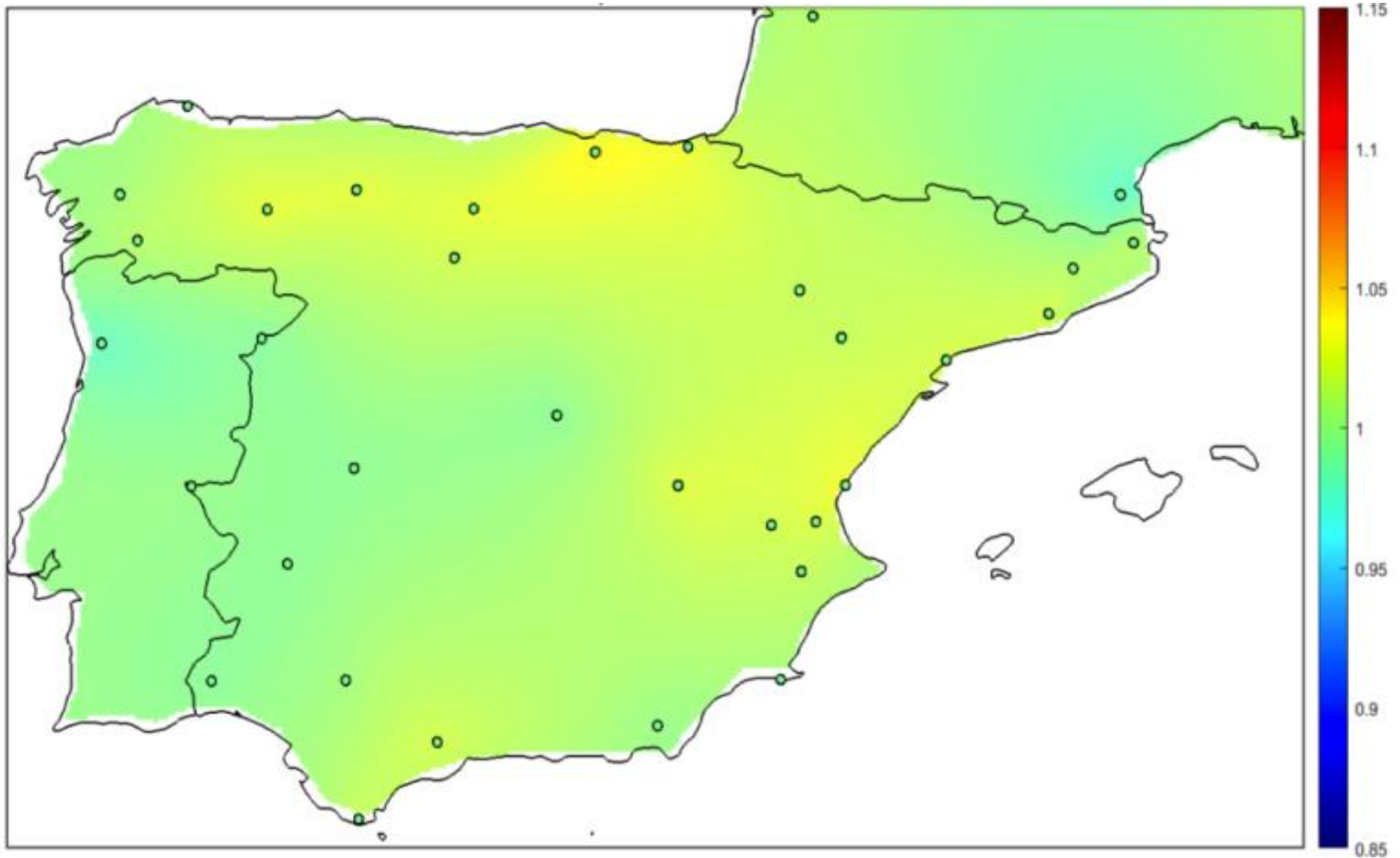

Contents

1. General information

Affected area

System condition before the blackout

2. Power system oscillations

PMU measurements and major windows

Local oscillations

Inter-area oscillations

Countermeasures

3. Contribution of renewable generation

4. Possible control solutions

Major Events

PMU Locations



Major Windows

From 12:03 to 12:50 CEST

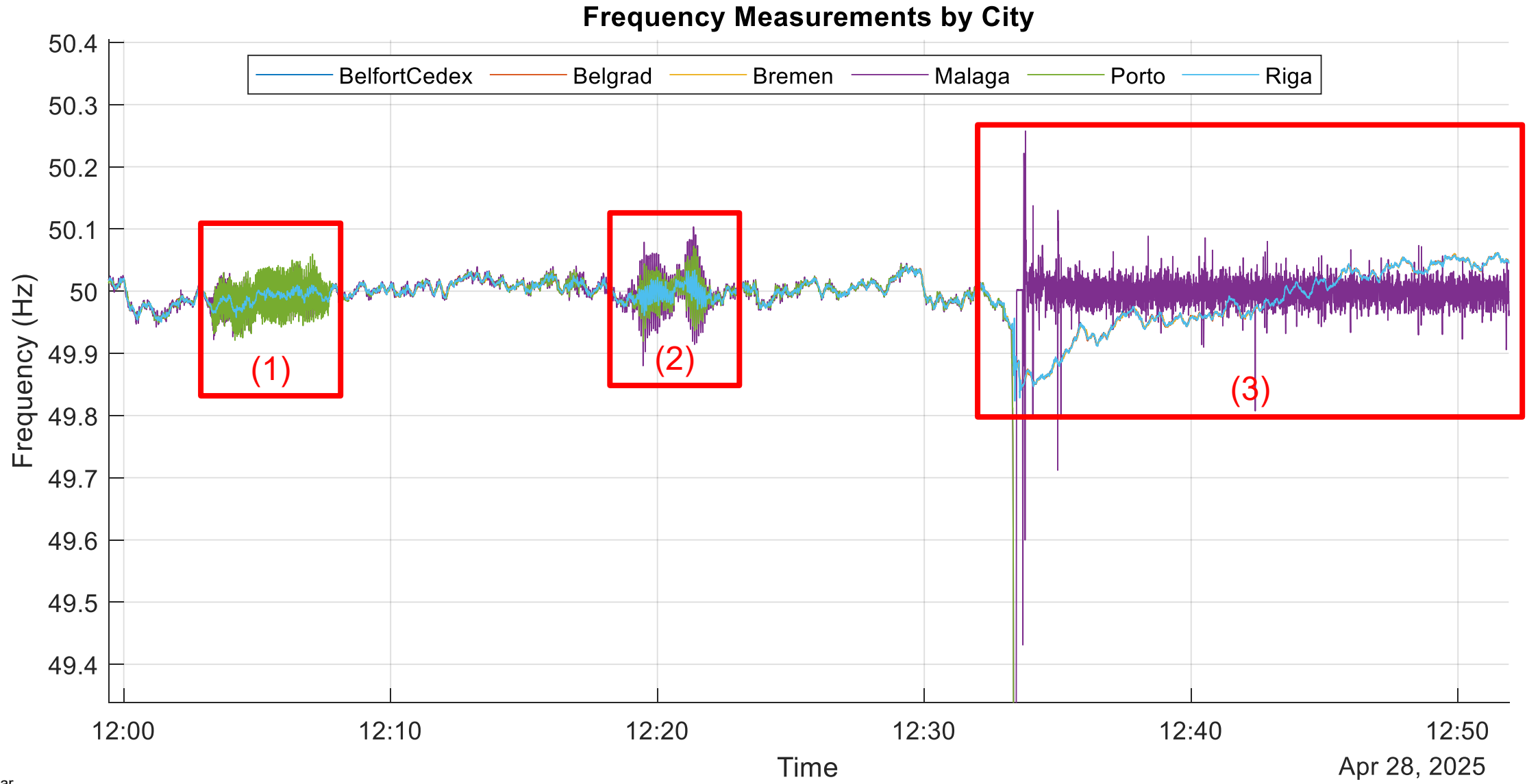

(1) Local Oscillations

From 12:03 to 12:07 CEST

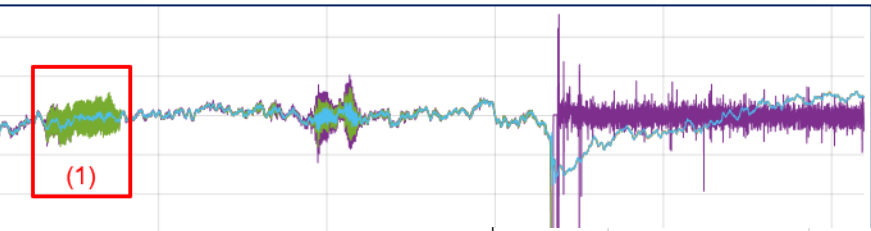

Frequency Measurements by City

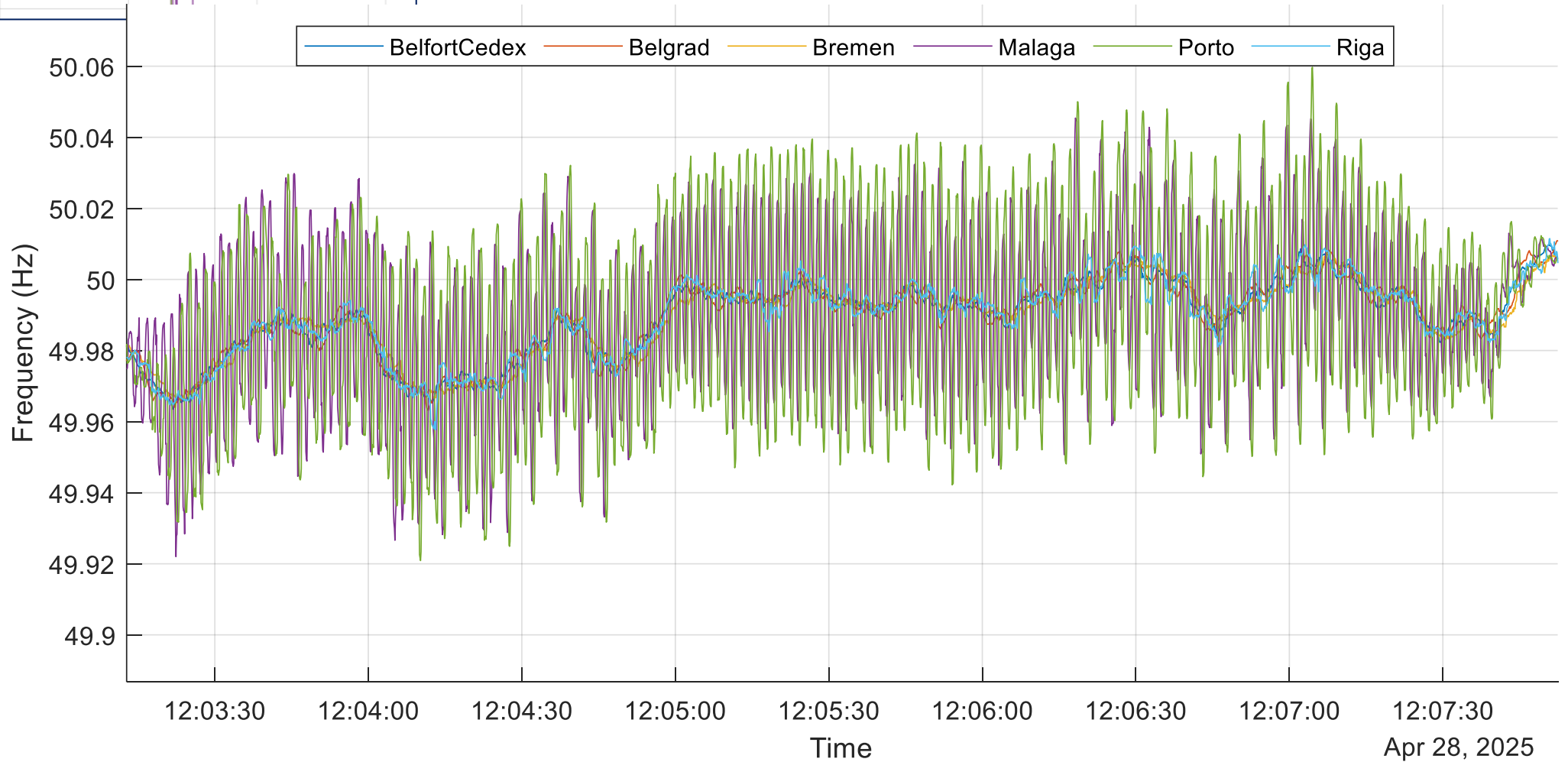

(1) Local Oscillations

From 12:03 to 12:07 CEST

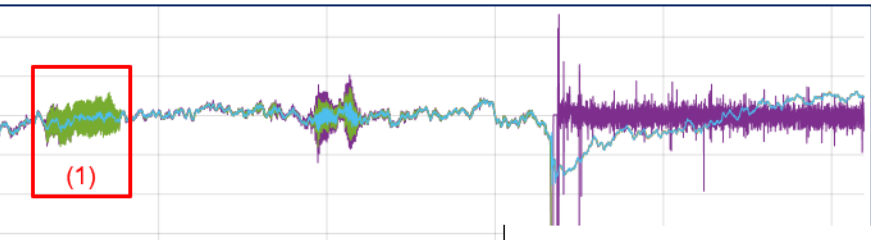

Frequency Measurements by City

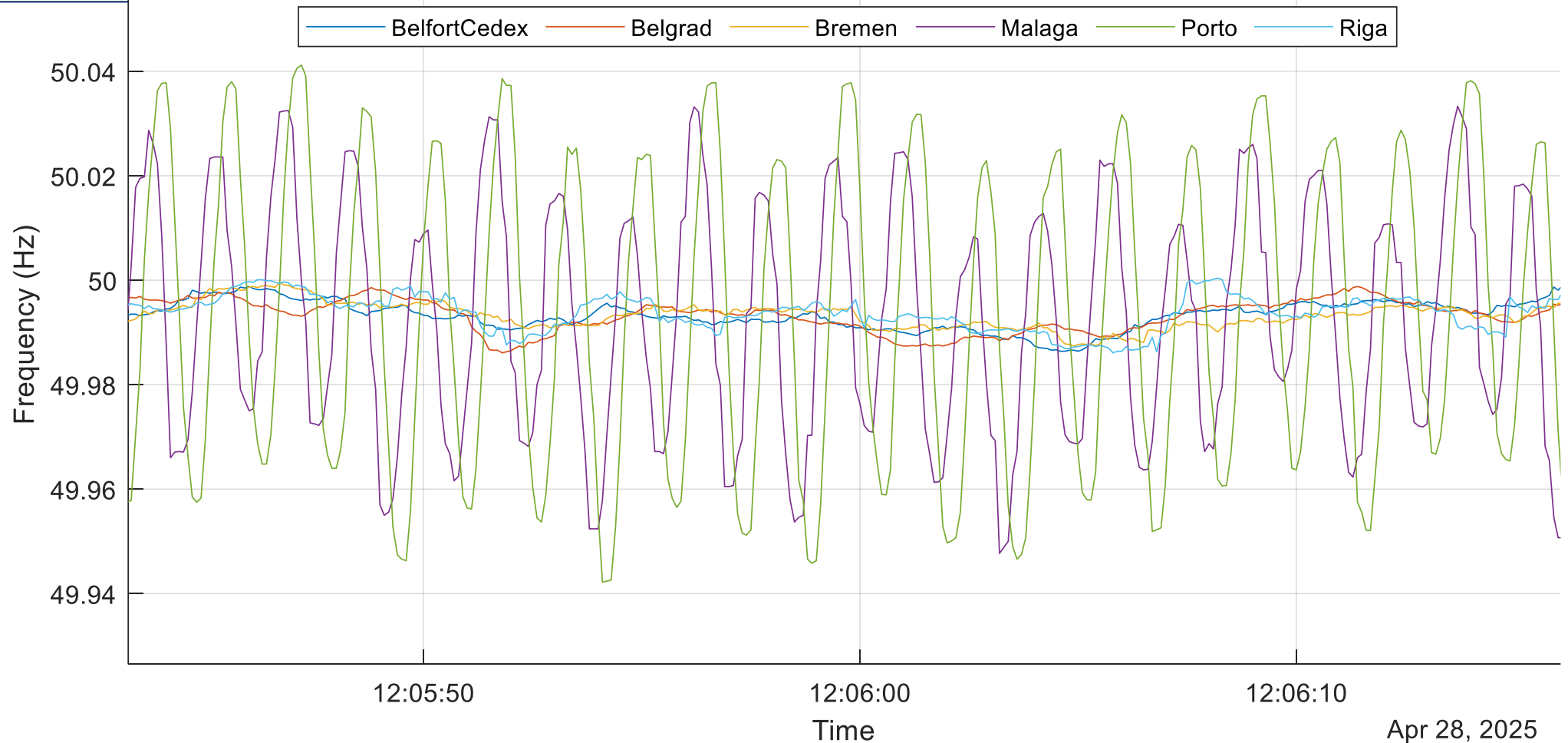

Modal Analysis

Local Modes - Eigenvalues

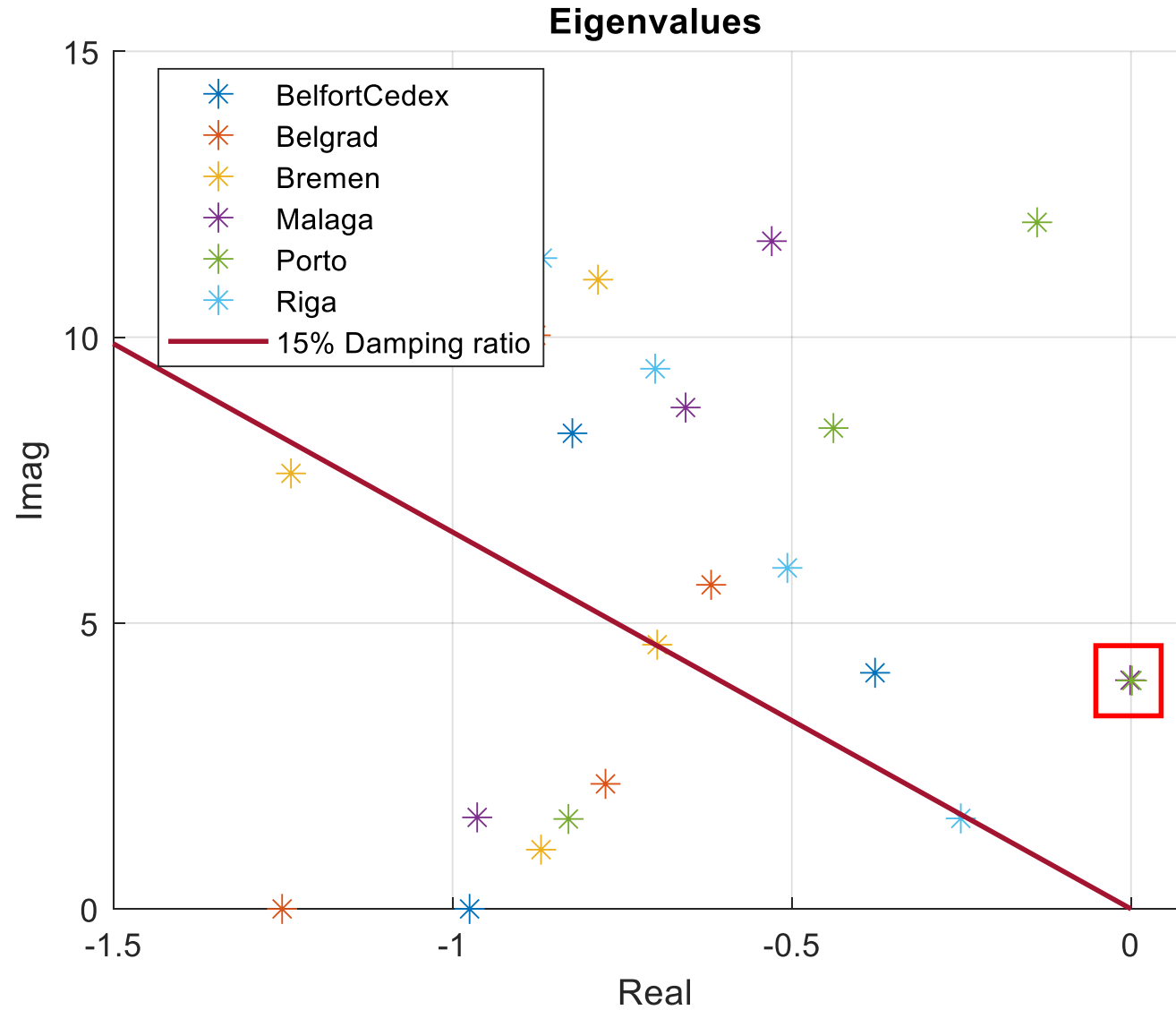

Modal Analysis

Local Modes - Eigenvalues

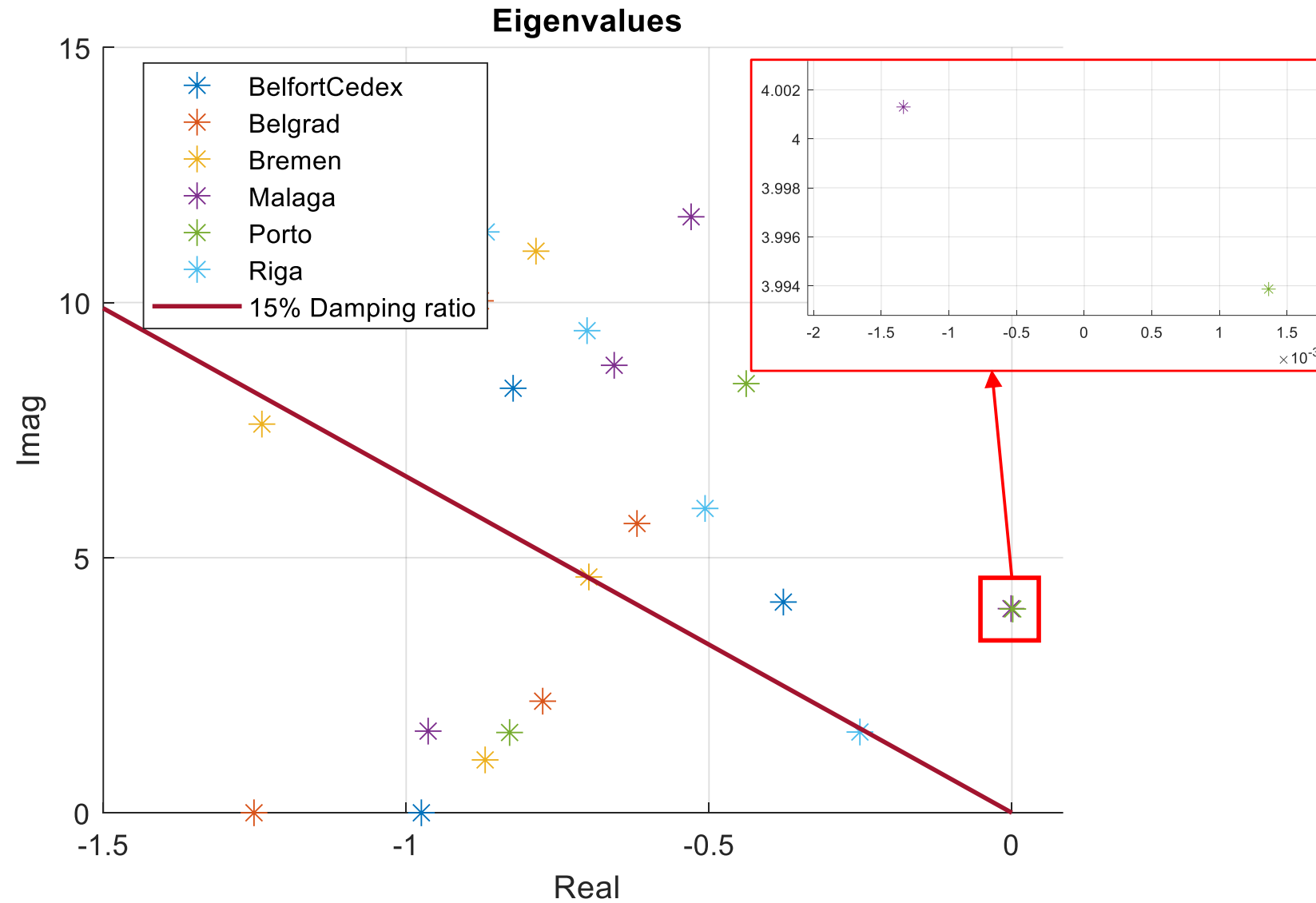

Modal Analysis

Local Modes - Eigenvectors

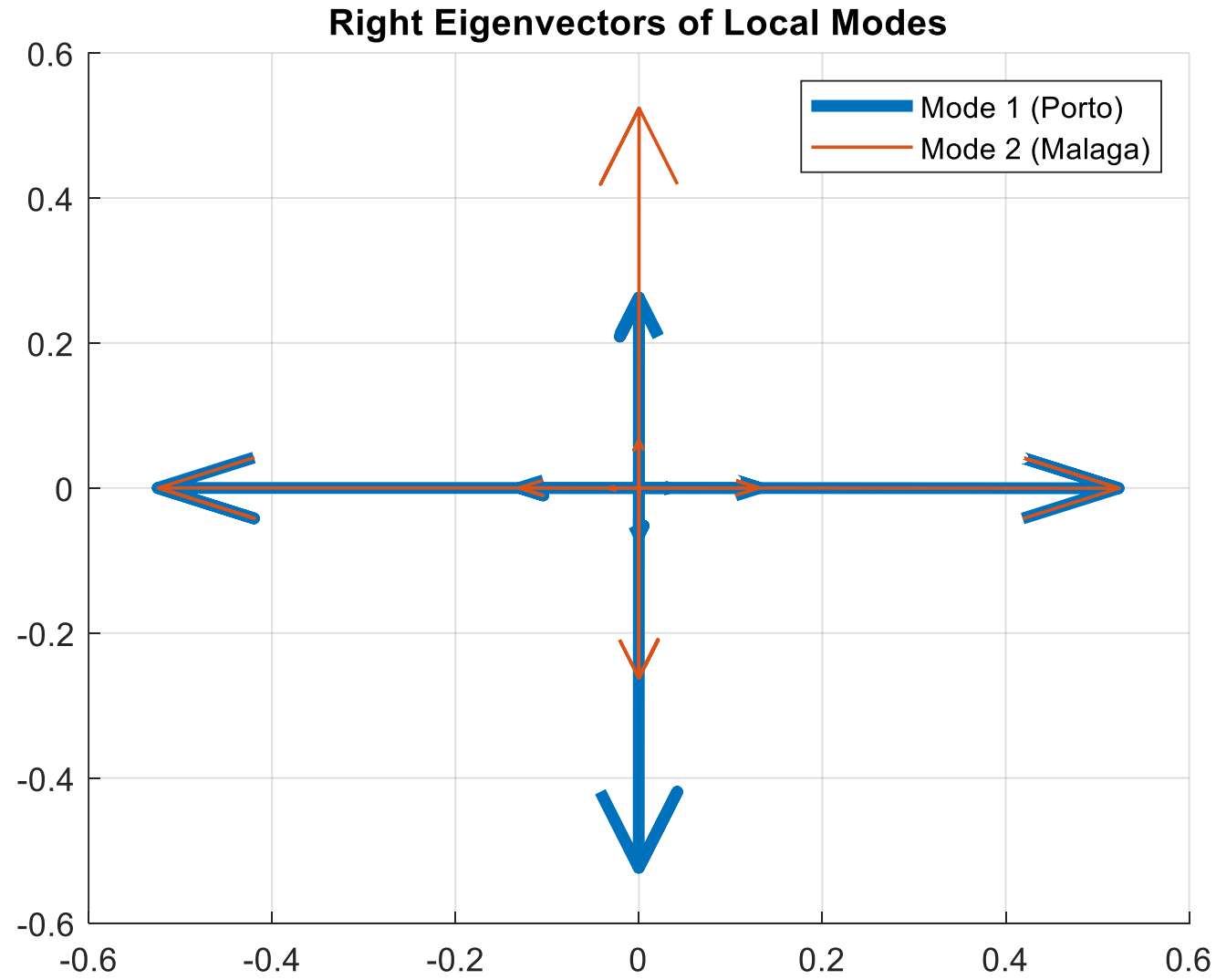

Countermeasures

For Damping Local Oscillations

- 1. Lines were switched on to decrease the system impedance and improve the stability**
- 2. Fixed power operation mode was set up on the HVDC link between Spain and France as this is an effective measure to mitigate oscillations**
- 3. The flow between Spain and France was reduced (as additional countermeasure to decrease Iberian center of inertia angle against the rest of the Continental Europe power system)**
- 4. Shunt reactors maneuvers were taken to recover voltage (that reached low values transiently during the oscillation)**

Effects of the Countermeasures

For Damping Local Oscillations

- 1. After this first action, the voltage angles of the system at 12:15 CEST came back to the values before the first oscillation due to an increase of exchanges between Spain and France, invalidating the previous countertrading action.**
- 2. The angle increase again created the conditions for the second oscillation.**

Effects of the Countermeasures

For Damping Local Oscillations

1. After this first action, the voltage angles of the system at 12:15 CEST came back to the values before the first oscillation due to an increase of exchanges between Spain and France, **invalidating the previous countertrading action.**
2. **The angle increase again** created the conditions for the second oscillation.

(2) Inter-area Oscillations

From 12:19 to 12:22 CEST

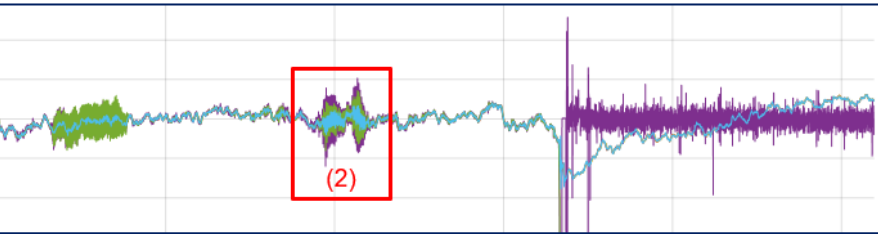

Frequency Measurements by City

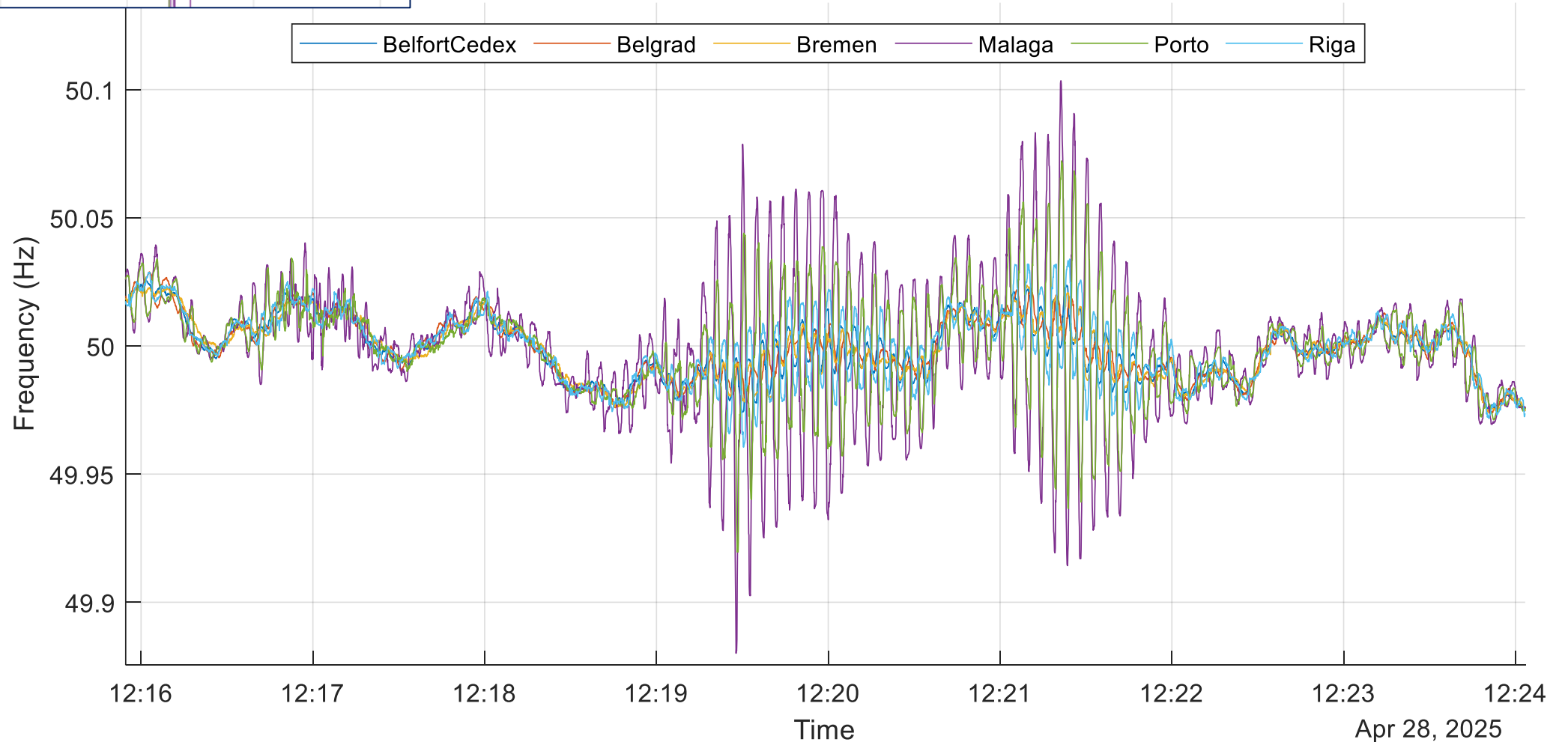

(2) Inter-area Oscillations

From 12:19 to 12:22 CEST

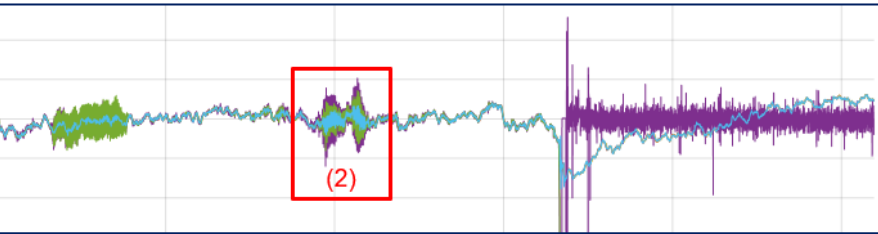

Frequency Measurements by City

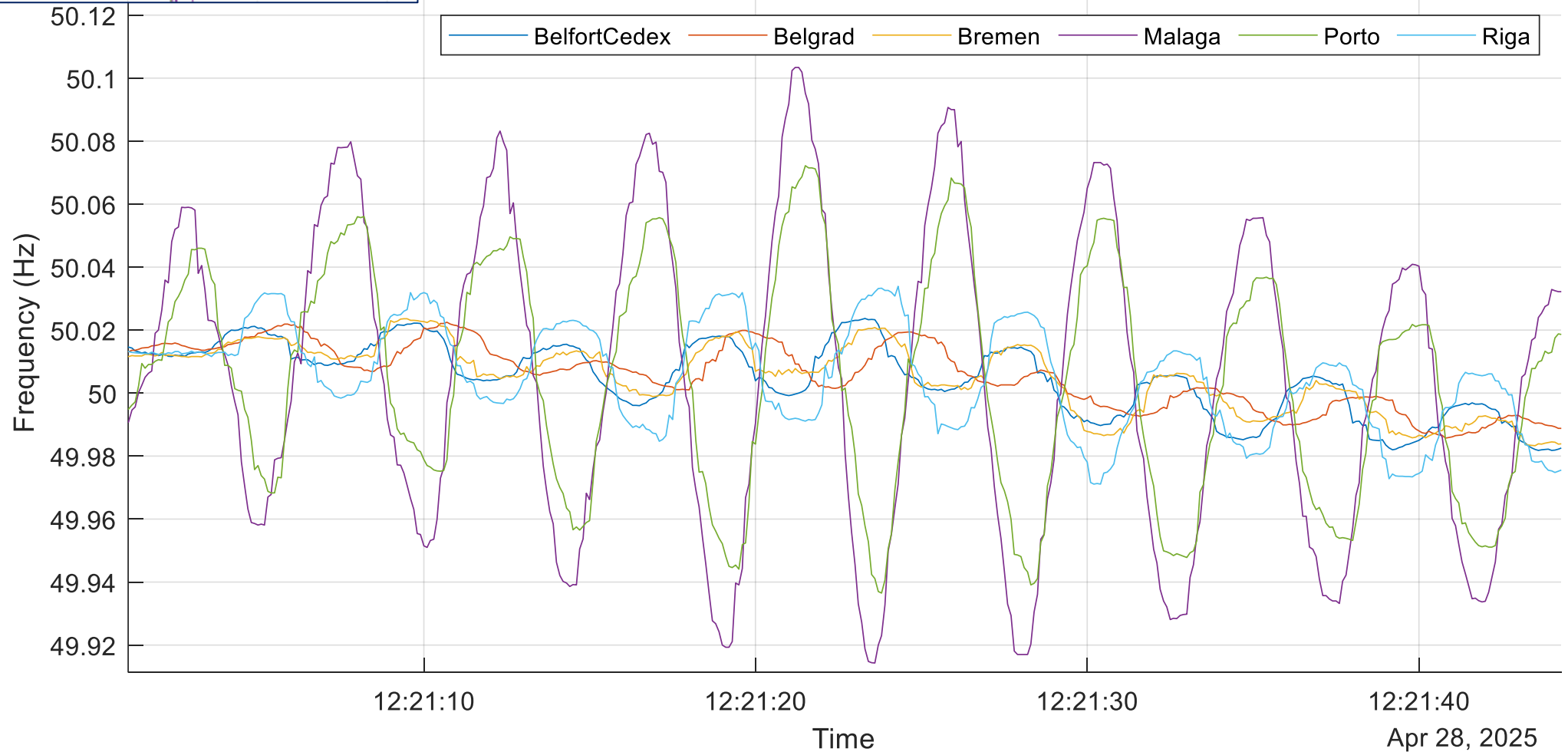

Modal Analysis

Inter-area Modes - Eigenvalues

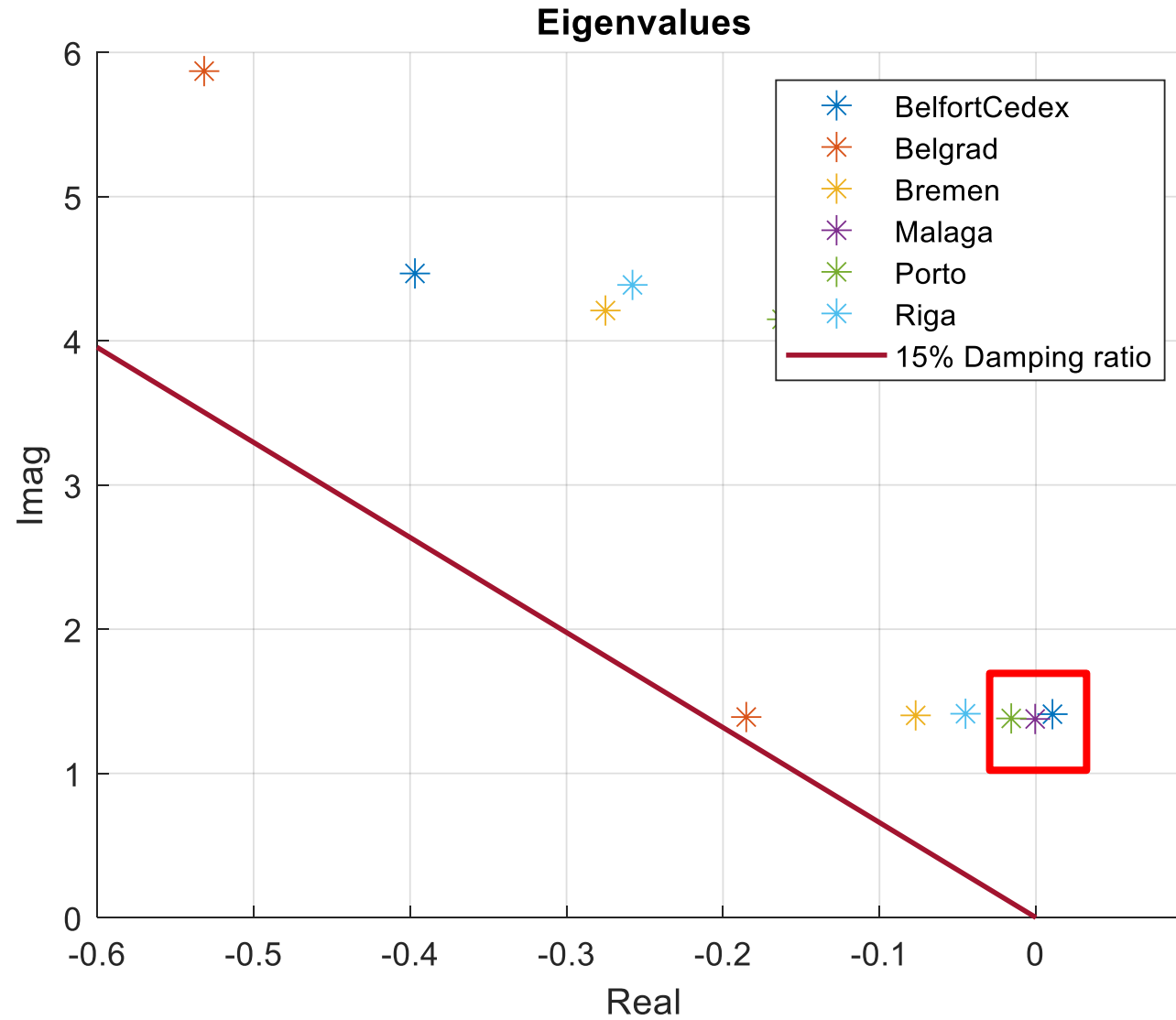

Modal Analysis

Inter-area Modes - Eigenvectors

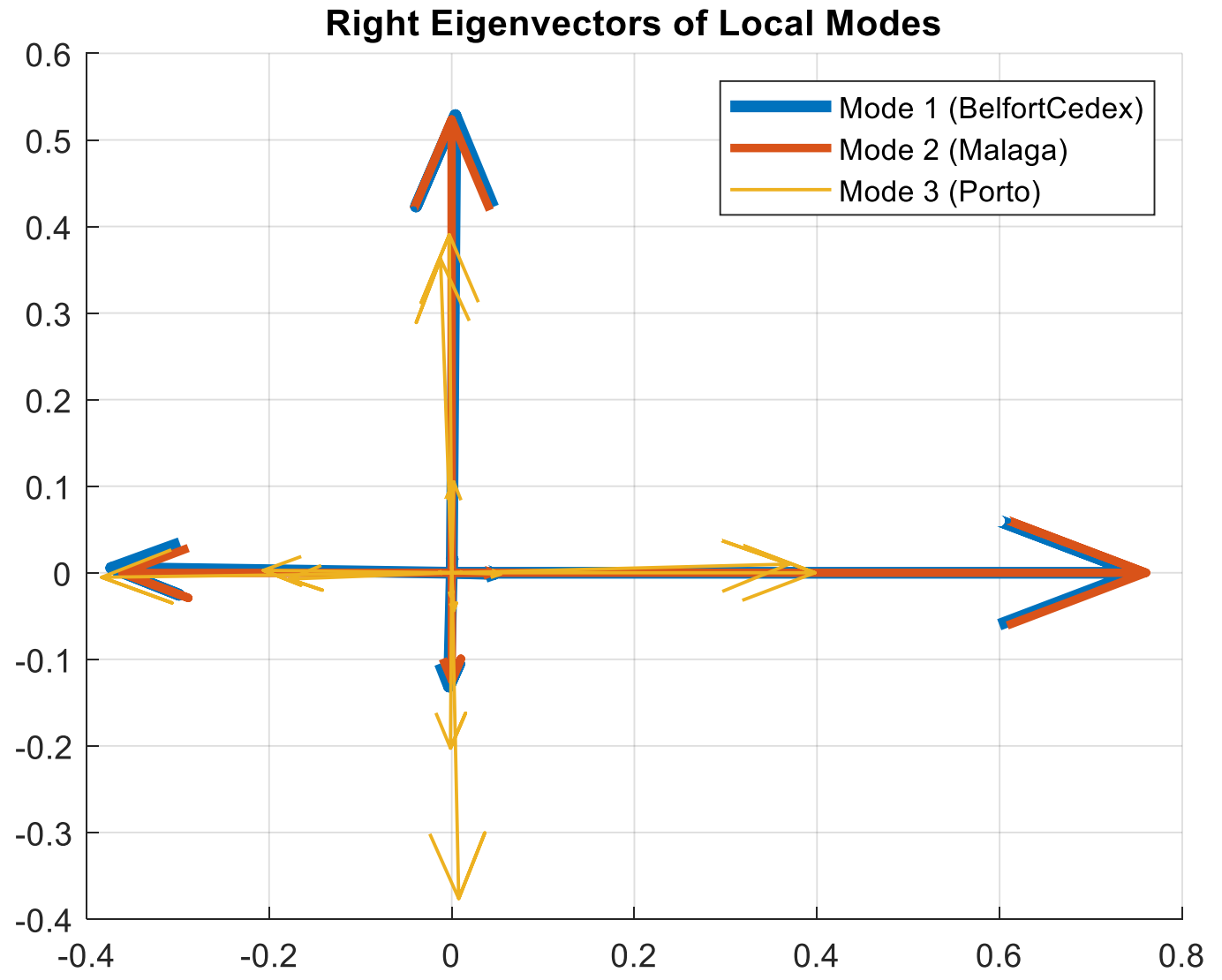

Countermeasures

For Damping Inter-area Oscillations

- 1. Further reduce power flows between Spain and France**
- 2. Coupling of the internal power lines in the South of Spain.**

Sequence of Events

Carmona Substation Voltage and Spain Power Exchange

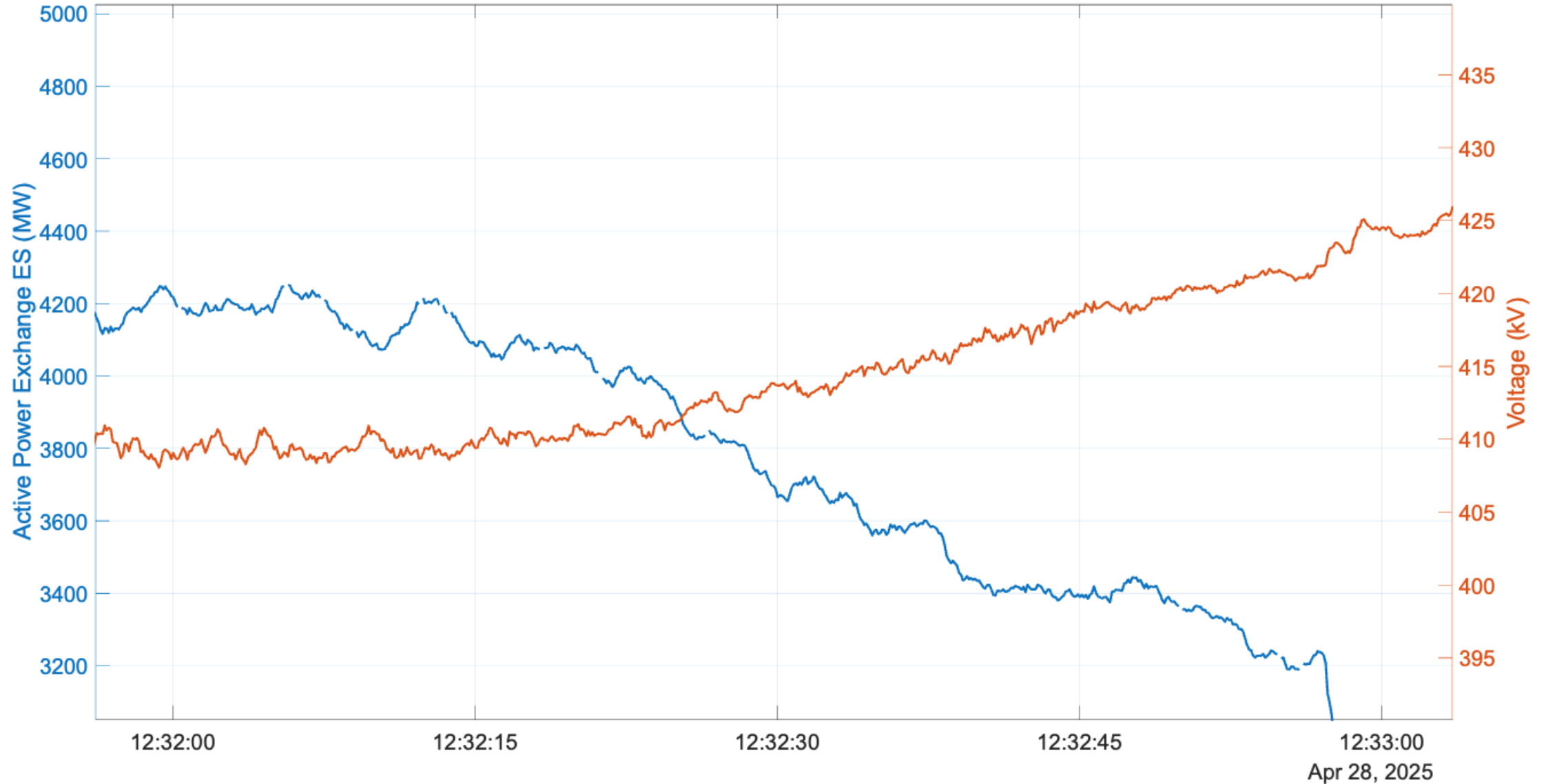

Before the Blackout

Spain Power Exchange

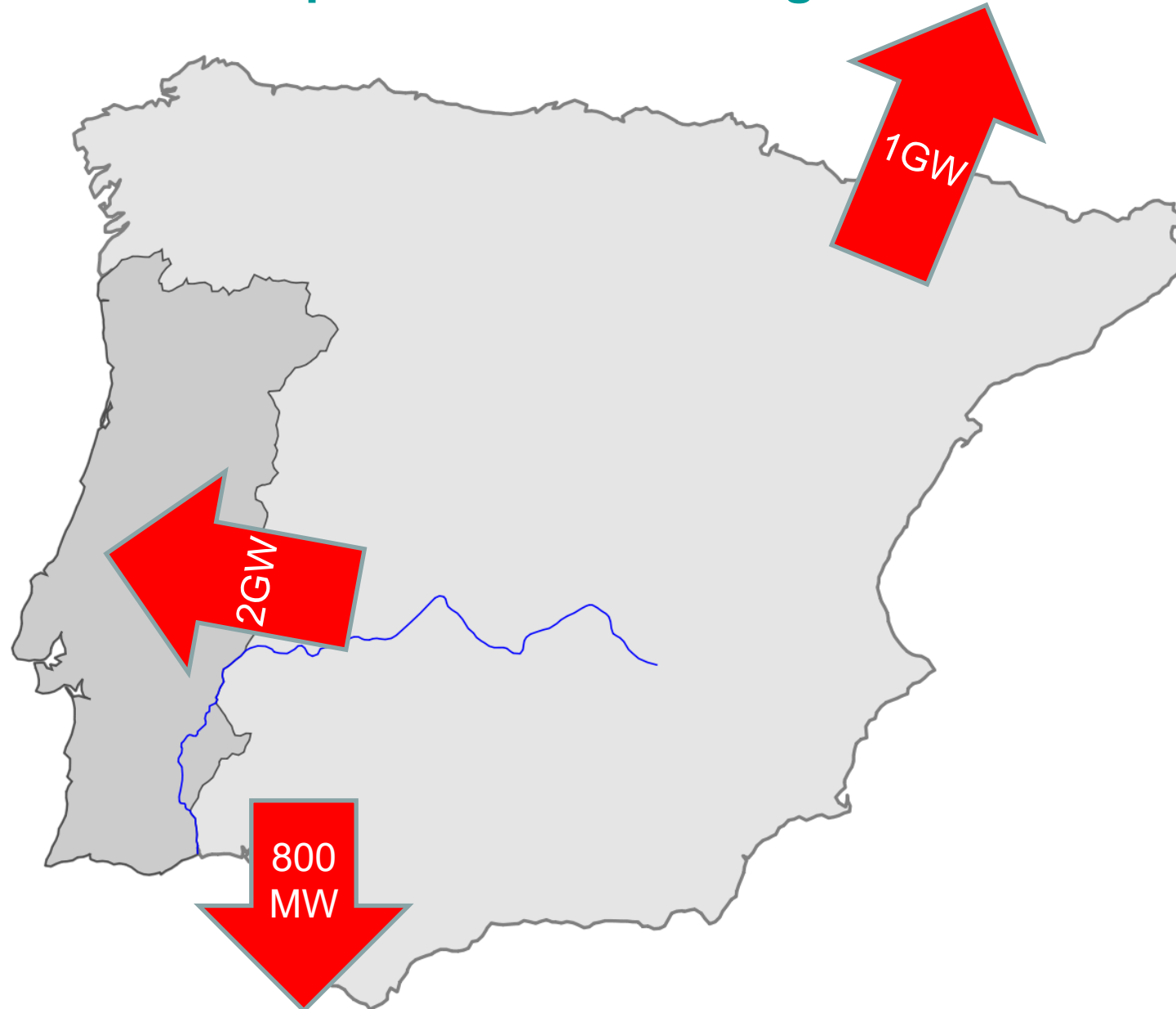

1. Event: 12:32:57

Loss of Generation of 355MW

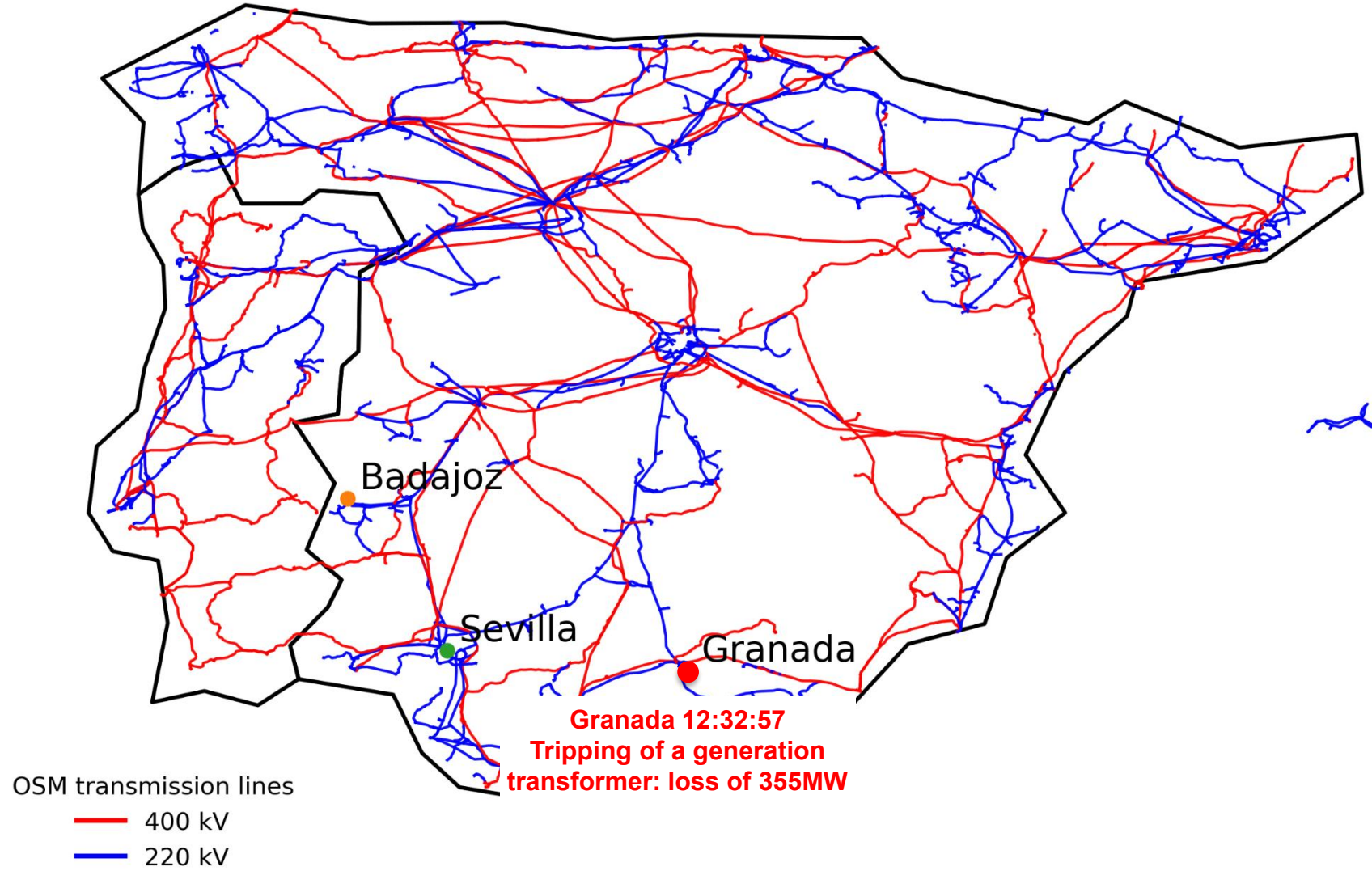

Voltage Profile after 1. Event

Heat Map of the 400kV Grid Voltage (p.u.)

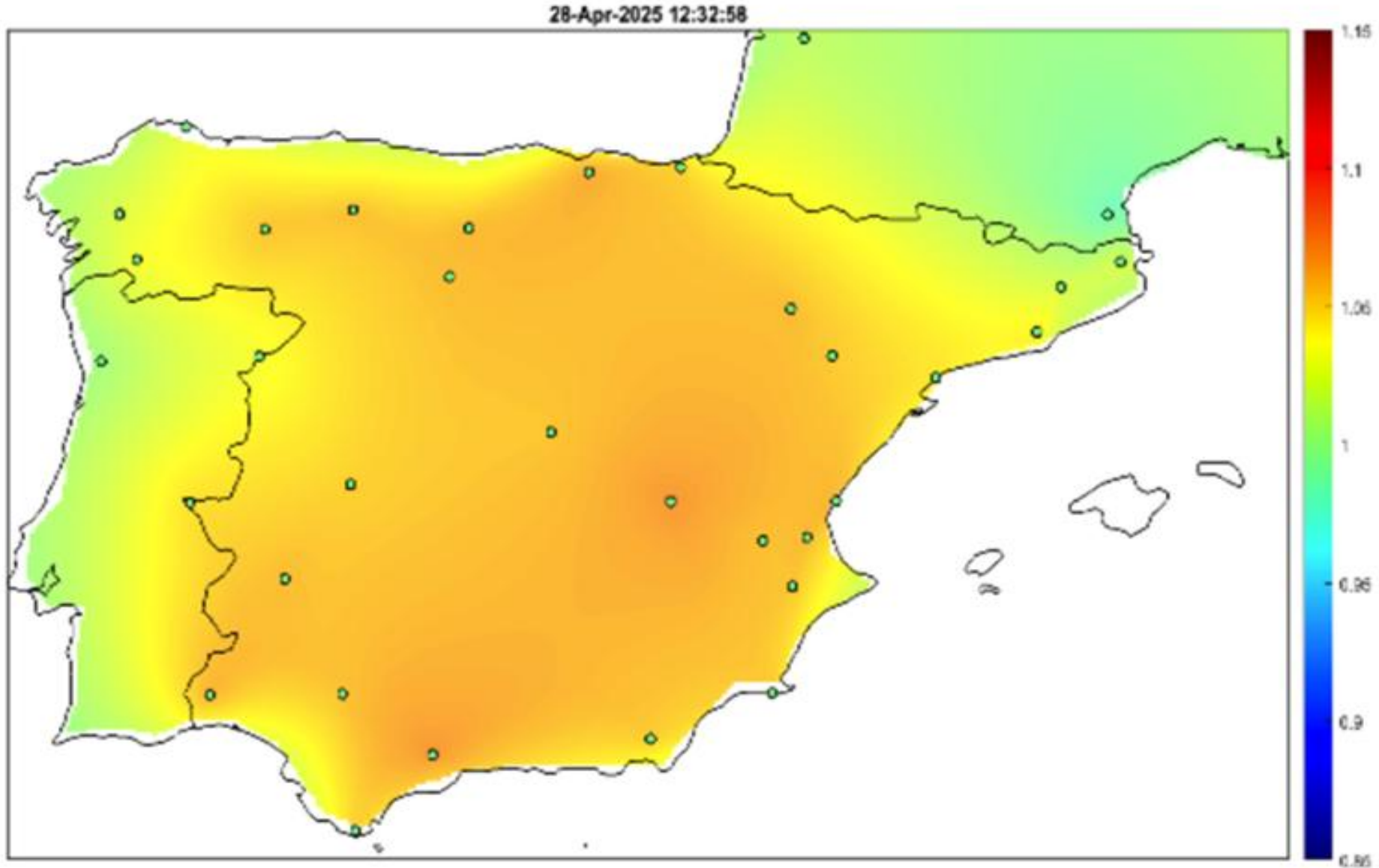

2. Event: 12:33:16

Loss of Generation of 720MW

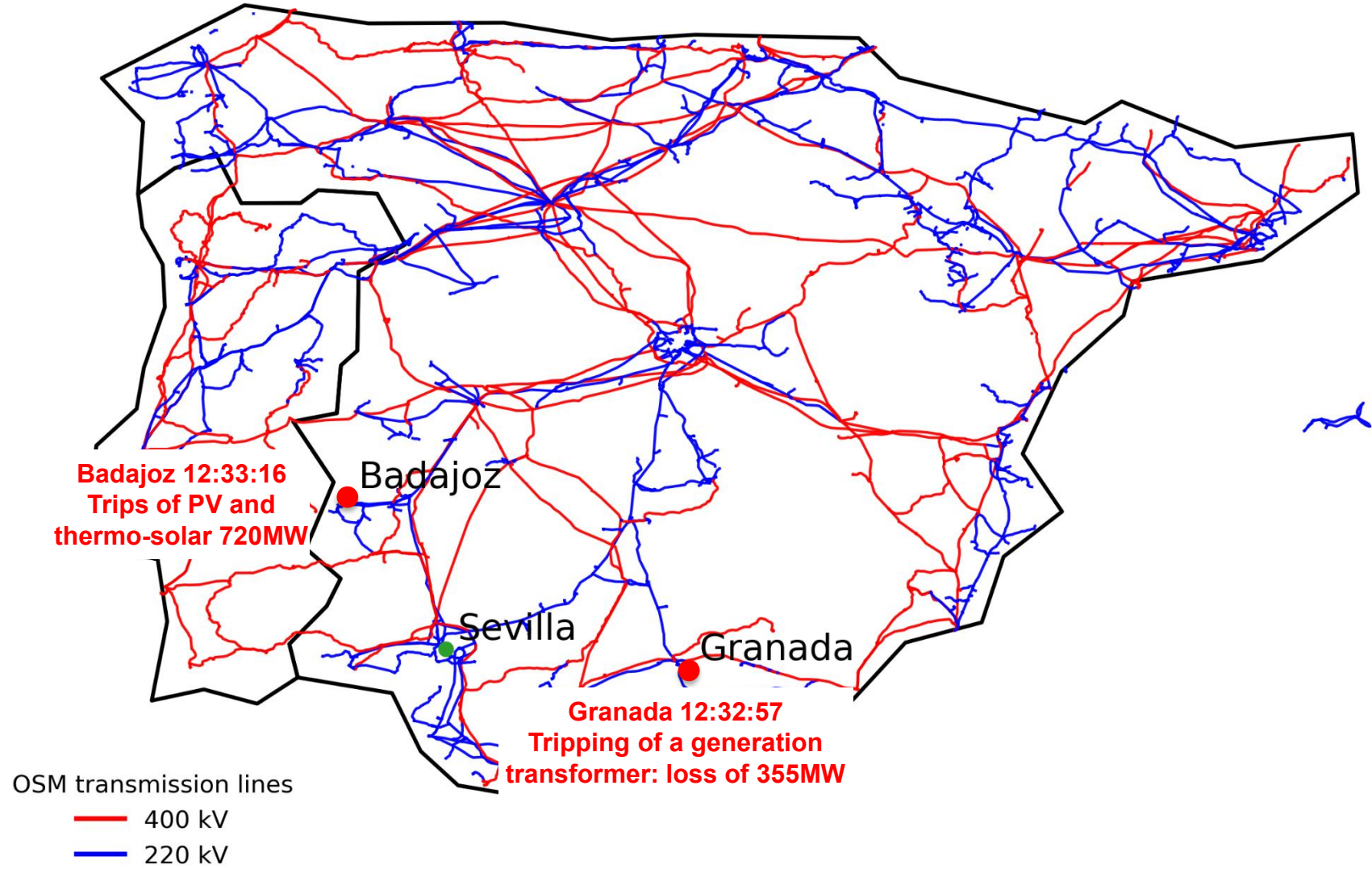

Voltage Profile after 2. Event

Heat Map of the 400kV Grid Voltage (p.u.)

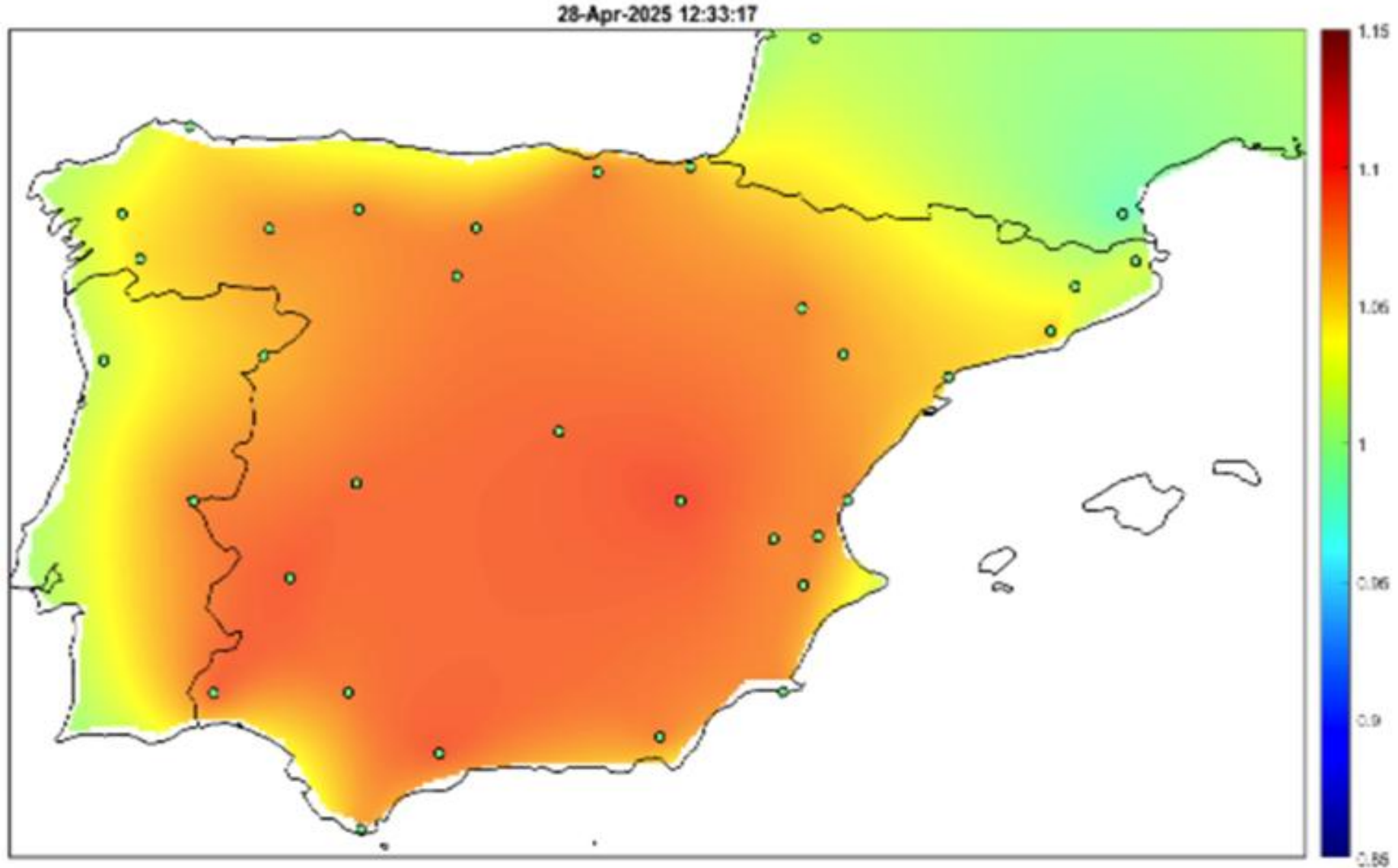

3. Event: 12:33:17

Loss of Generation of 1100MW

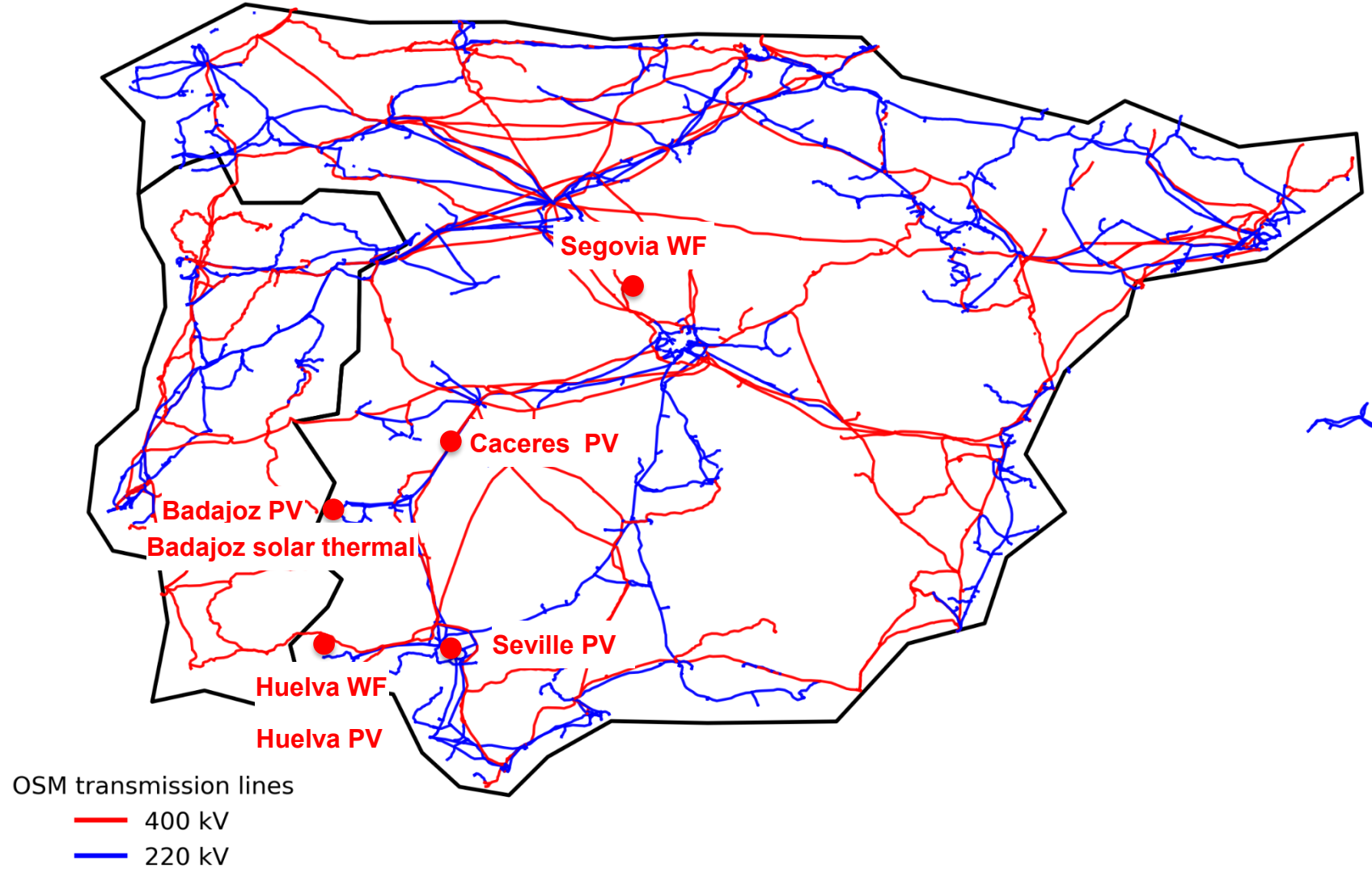

Voltage Profile after 3. Event

Heat Map of the 400kV Grid Voltage (p.u.)

28-Apr-2025 12:33:18

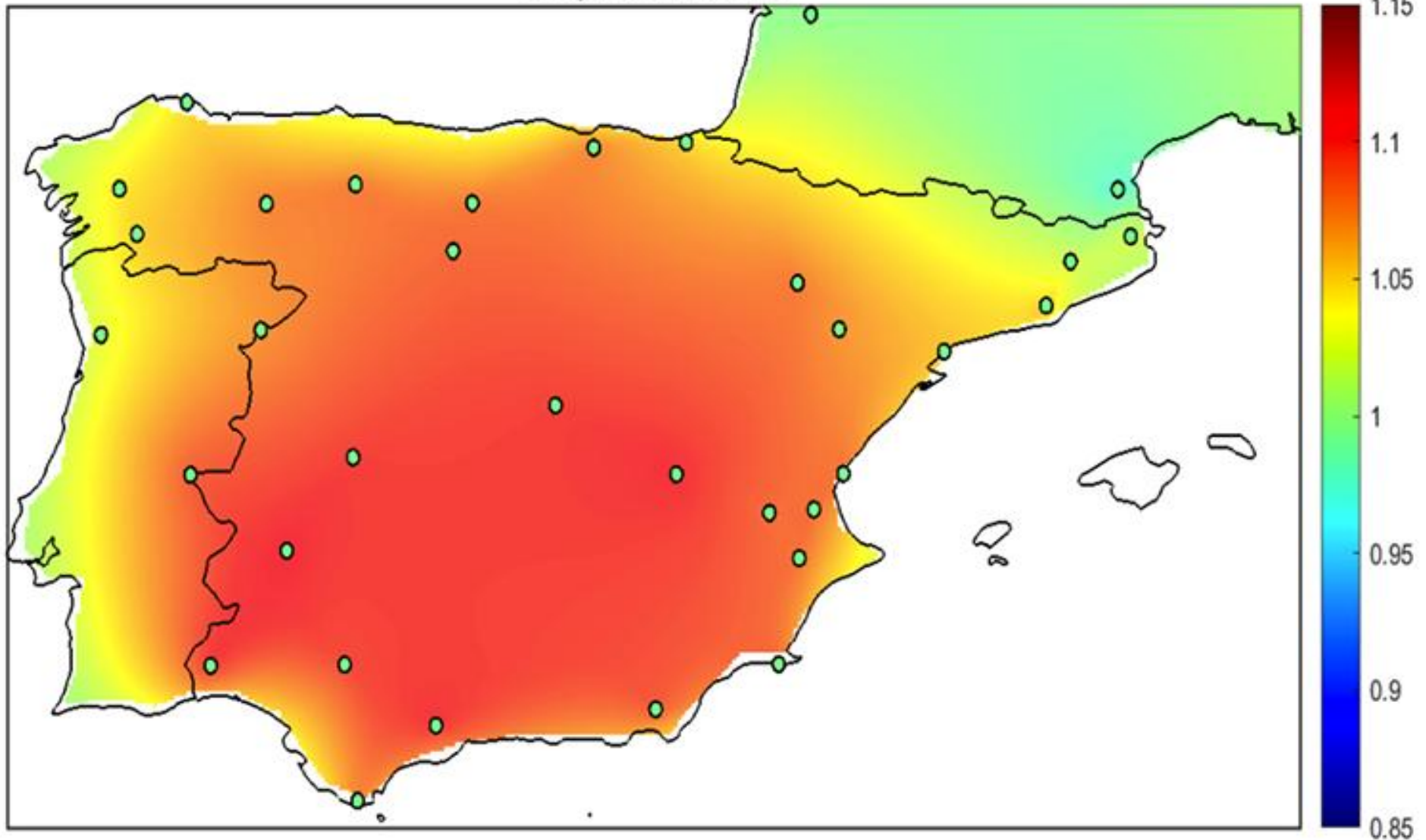

Contents

1. General information

Affected area

System condition before the blackout

2. Power system oscillations

PMU measurements and major windows

Local oscillations

Inter-area oscillations

Countermeasures

3. Contribution of renewable generation

4. Possible control solutions

Blackout in Spain and Portugal

Power Generations on 28 April 2025 12:25

Progressive cumulative generation and storage structure (MW) at 12:25 - 28/04/2025

Demand	25283	- (%)
Andorra export	-8	0 (%)
Morocco export	-745	0 (%)
Portugal export	-2818	0 (%)
France export	-778	0 (%)
Batteries		(%)
Pumping turbine	28	0,09 (%)
Nuclear	3391	10,43 (%)
Charcoal	228	0,7 (%)
Combined cycle	983	3,02 (%)
Cogeneration and waste	1402	4,31 (%)
Hydraulics	3207	9,86 (%)
Wind	3507	10,79 (%)
Solar photovoltaic	17888	55,01 (%)
Solar thermal	1505	4,63 (%)
Renewable thermal	377	1,16 (%)
Pumping consumption	-3038	0 (%)
Battery consumption	-8	0 (%)
Balearic link	-102	0 (%)
France imports		(%)
Portugal imports		(%)
Morocco imports		(%)

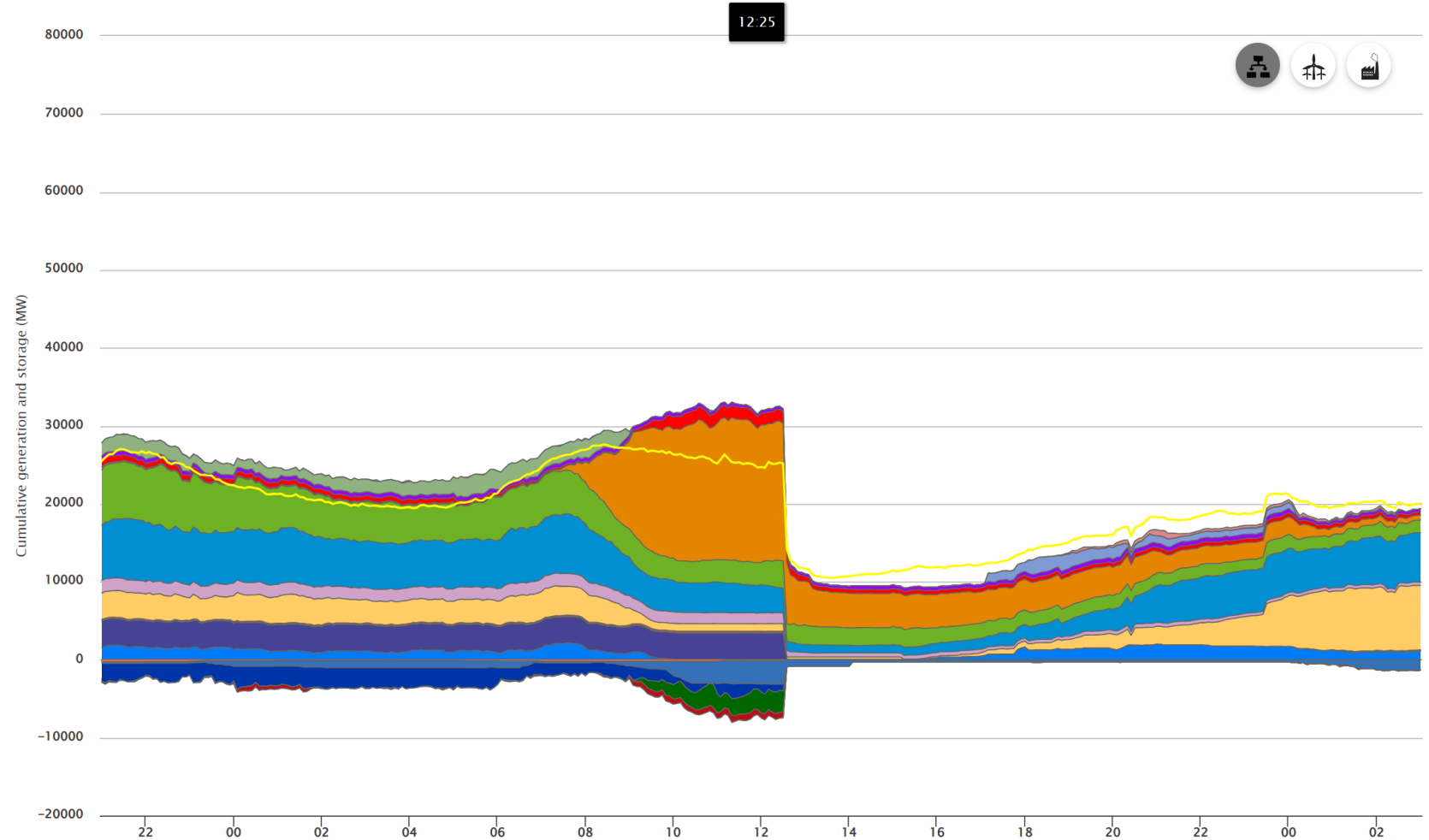

Blackout in Spain and Portugal

Power Generations on 28 April 2025 13:00

Progressive cumulative storage and generation structure (MW) at 13:00 - 28/04/2025

Demand	11654	- (%)
Andorra export		(%)
Morocco export		(%)
Portugal export	-1	0 (%)
France export		(%)
Batteries		(%)
Pumping turbine	28	0,25 (%)
Nuclear		(%)
Charcoal		(%)
Combined cycle	326	2,96 (%)
Cogeneration and waste	566	5,13 (%)
Hydraulics	1024	9,29 (%)
Wind	2525	22,9 (%)
Solar photovoltaic	5604	50,82 (%)
Solar thermal	598	5,42 (%)
Renewable thermal	356	3,23 (%)
Pumping consumption	-845	0 (%)
Battery consumption	-1	0 (%)
Balearic link		(%)
France imports		(%)
Portugal imports		(%)
Morocco imports		(%)

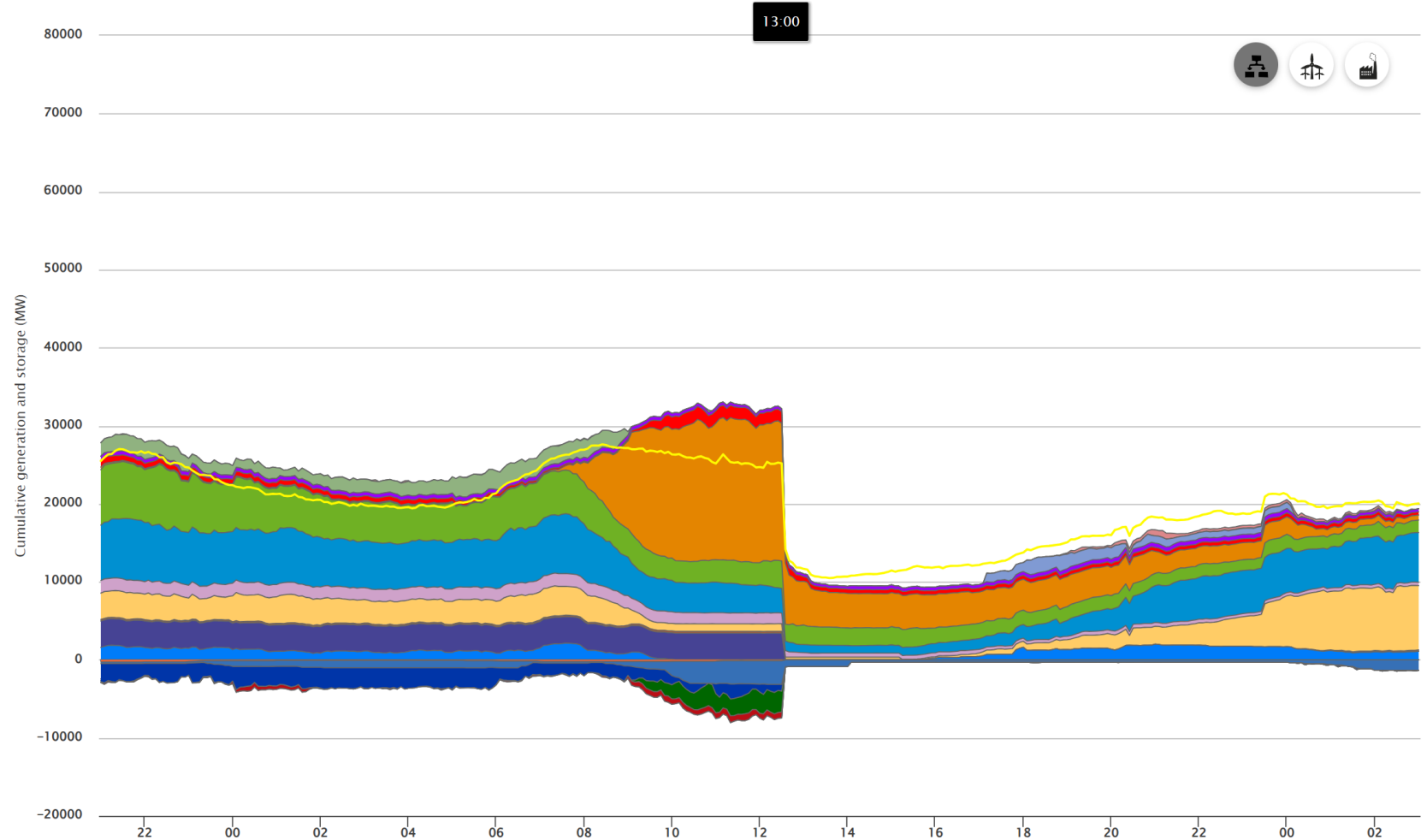

Blackout in Spain and Portugal

Power Generations on 28 April 2025 13:00

Progressive cumulative storage and generation structure (MW) at 13:00 - 28/04/2025

Demand	11654	- (%)
Andorra export		(%)
Morocco export		(%)
Portugal export	-1	0 (%)
France export		(%)
Batteries		(%)
Pumping turbine	28	0,25 (%)
Nuclear		(%)
Charcoal		(%)
Combined cycle	326	2,96 (%)
Cogeneration and waste	566	5,13 (%)
Hydraulics	1024	9,29 (%)
Wind	2525	22,9 (%)
Solar photovoltaic	5604	50,82 (%)
Solar thermal	598	5,42 (%)
Renewable thermal	356	3,23 (%)
Pumping consumption	-845	0 (%)
Battery consumption	-1	0 (%)
Balearic link		(%)
France imports		(%)
Portugal imports		(%)
Morocco imports		(%)

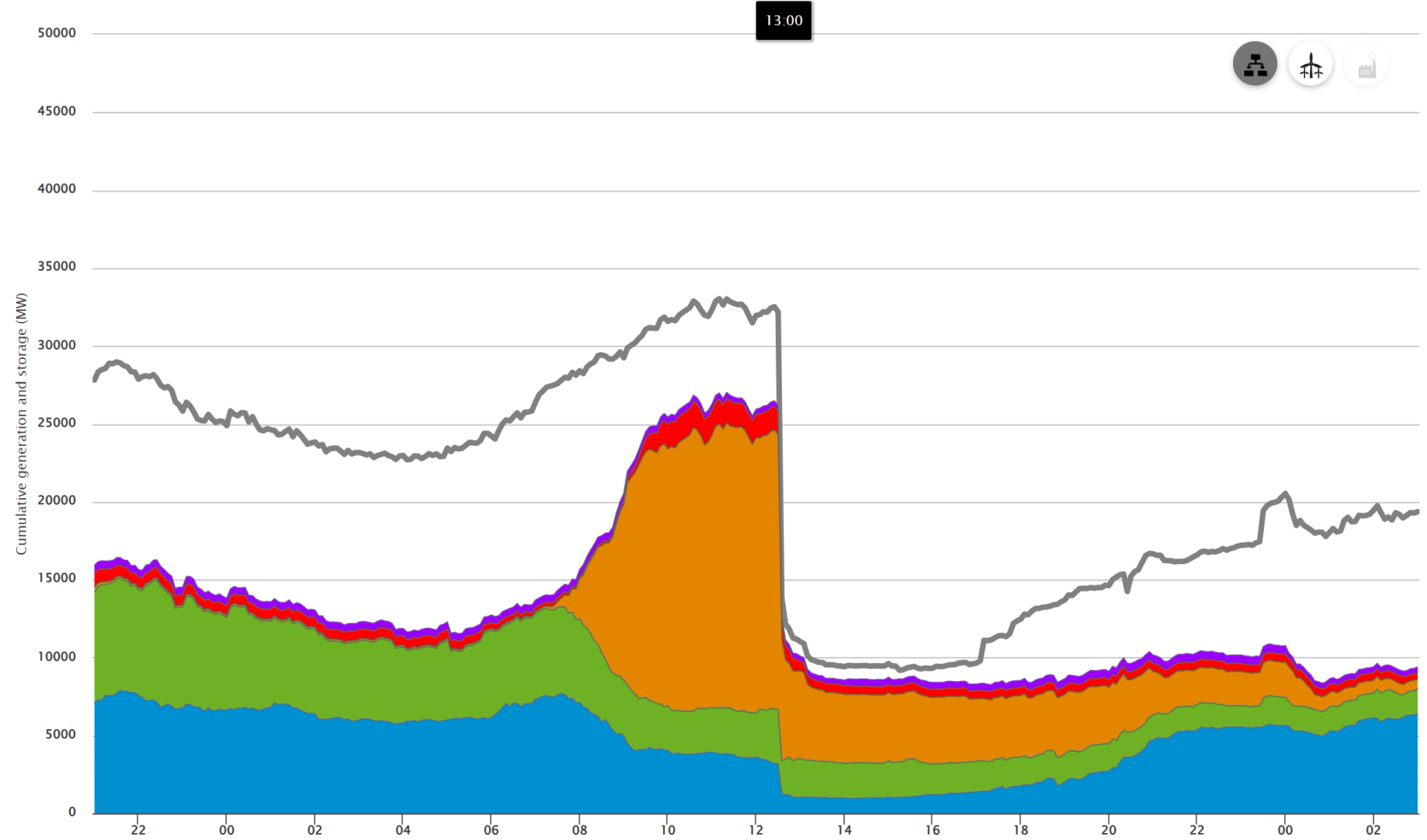

Blackout in Spain and Portugal

Power Generations on 28 April 2025 13:00

Progressive cumulative storage and generation structure (MW) at 13:00 - 28/04/2025

Demand	11654	- (%)
Andorra export		(%)
Morocco export		(%)
Portugal export	-1	0 (%)
France export		(%)
Batteries		(%)
Pumping turbine	28	0,25 (%)
Nuclear		(%)
Charcoal		(%)
Combined cycle	326	2,96 (%)
Cogeneration and waste	566	5,13 (%)
Hydraulics	1024	9,29 (%)
Wind	2525	22,9 (%)
Solar photovoltaic	5604	50,82 (%)
Solar thermal	598	5,42 (%)
Renewable thermal	356	3,23 (%)
Pumping consumption	-845	0 (%)
Battery consumption	-1	0 (%)
Balearic link		(%)
France imports		(%)
Portugal imports		(%)
Morocco imports		(%)

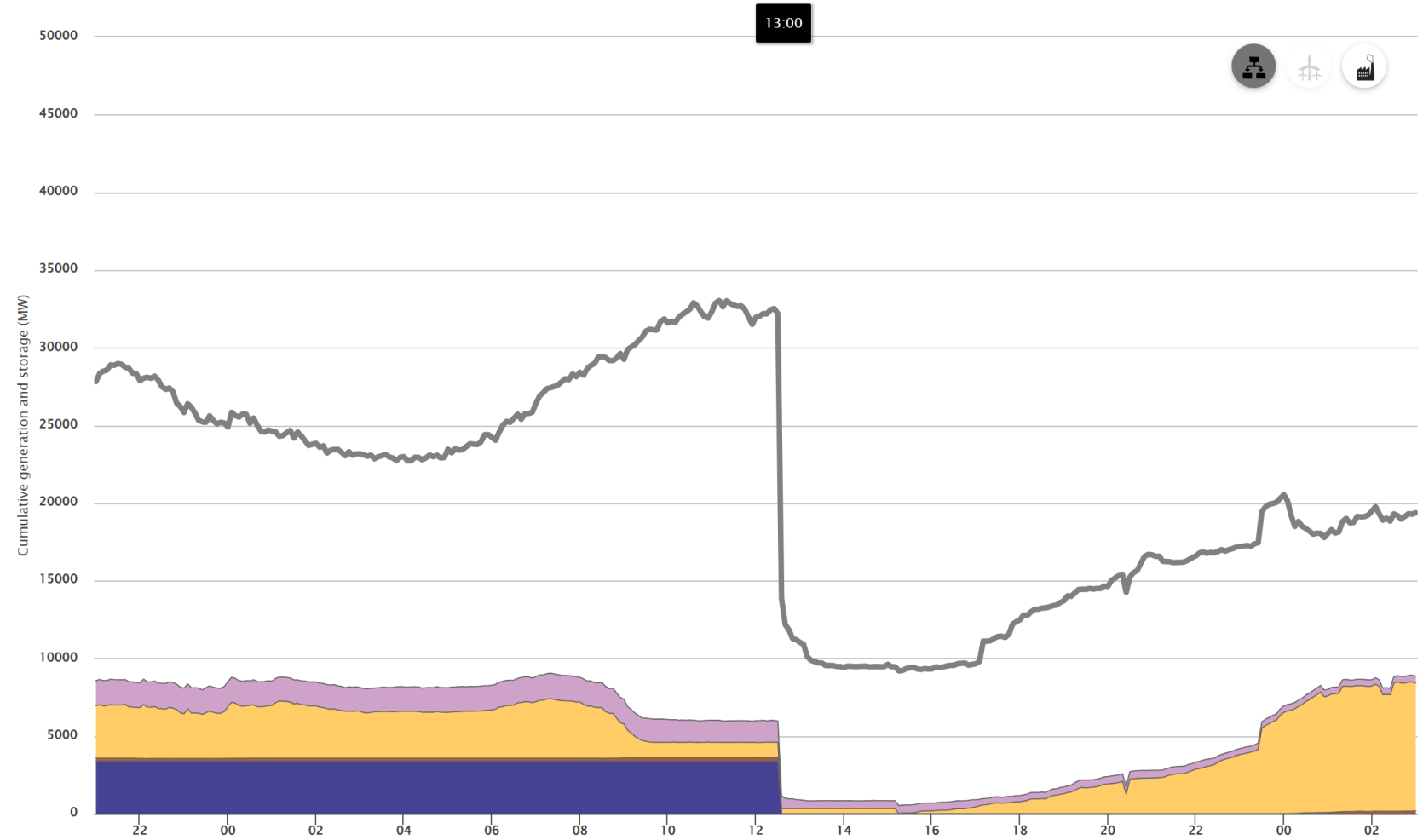

Blackout in Spain and Portugal

System Behavior after the Blackout

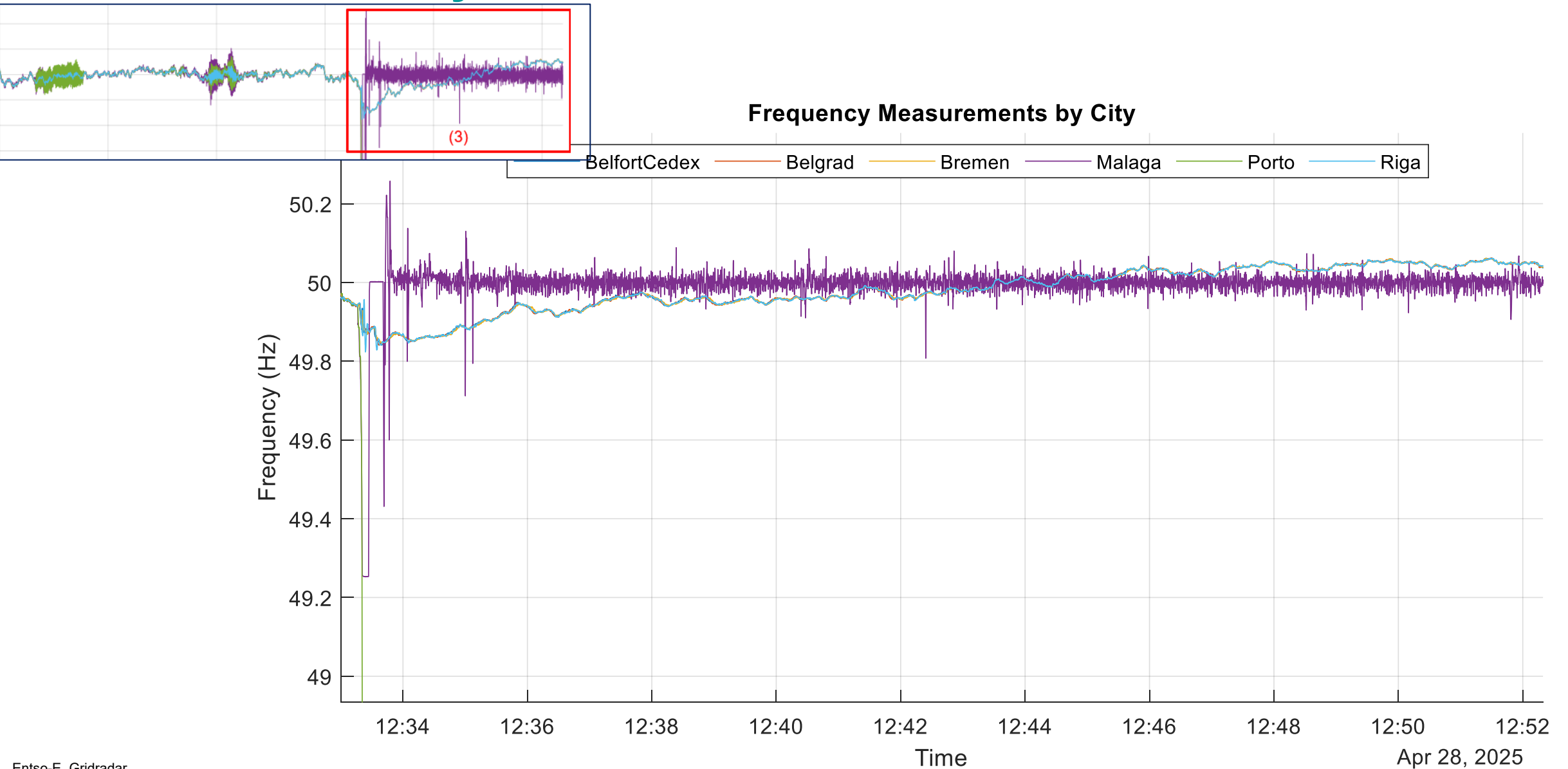

Blackout in Spain and Portugal

System Behavior after the Blackout

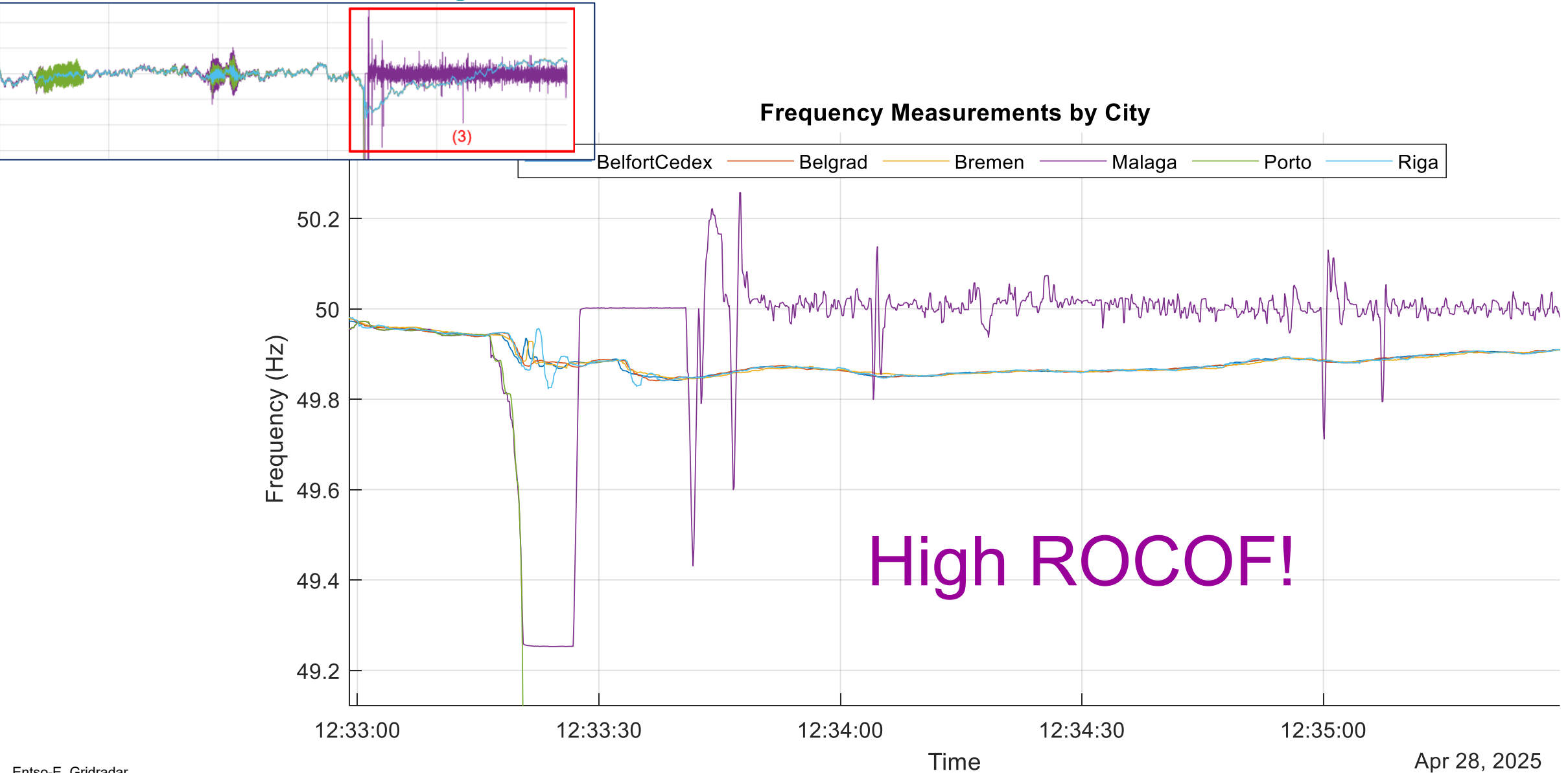

Contents

1. General information

Affected area

System condition before the blackout

2. Power system oscillations

PMU measurements and major windows

Local oscillations

Inter-area oscillations

Countermeasures

3. Contribution of renewable generation

4. Possible control solutions

Power System Stability

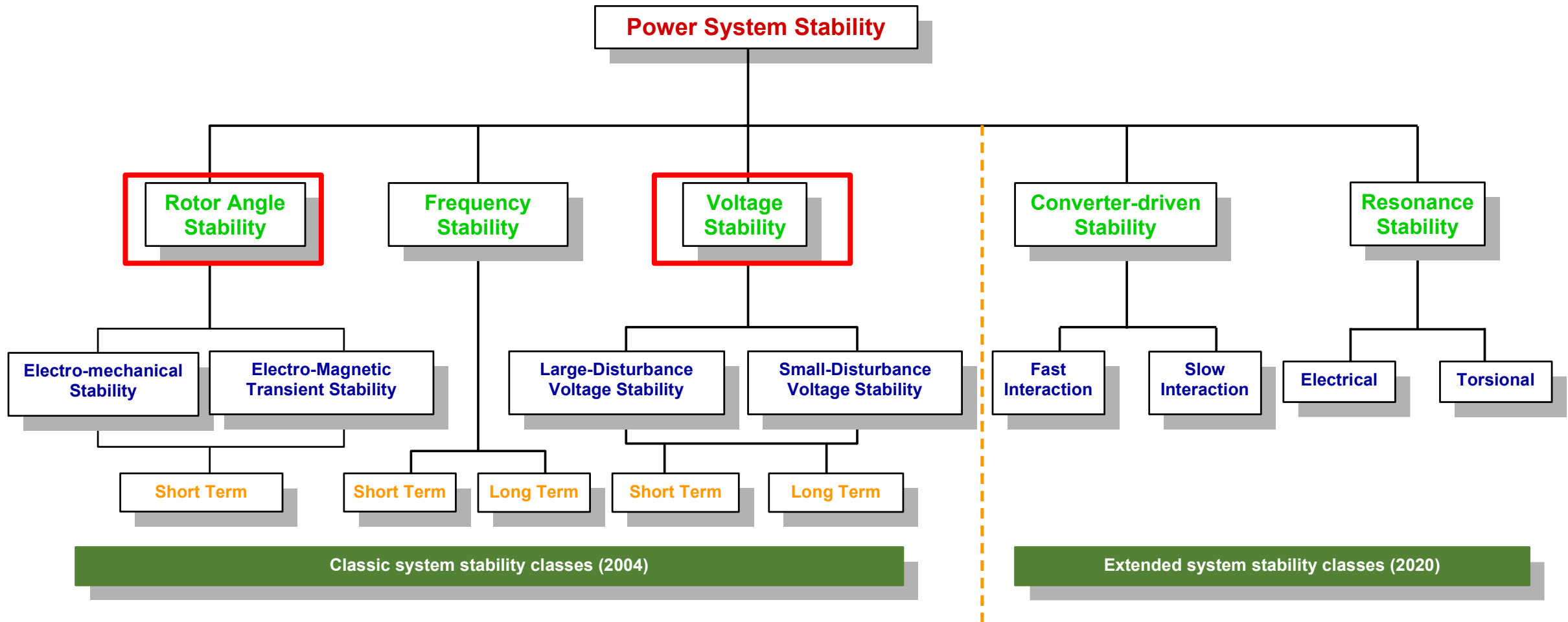

Small Signal Stability

Inter-area Oscillations in Europe 1997

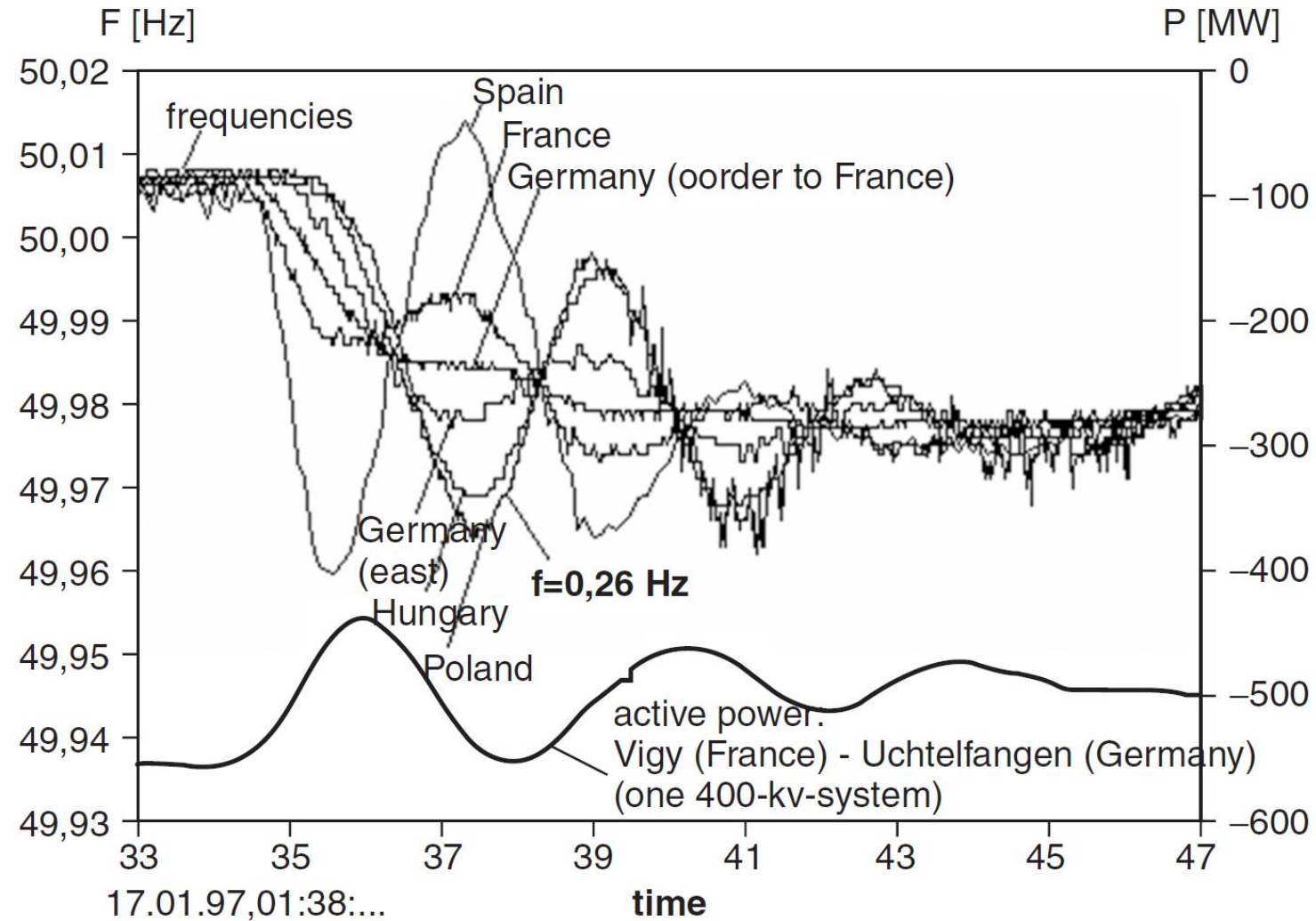

Research Areas

Inter-area Oscillation in Europe 1997

-Frequency 0.205 Hz

- Damping -2.8%

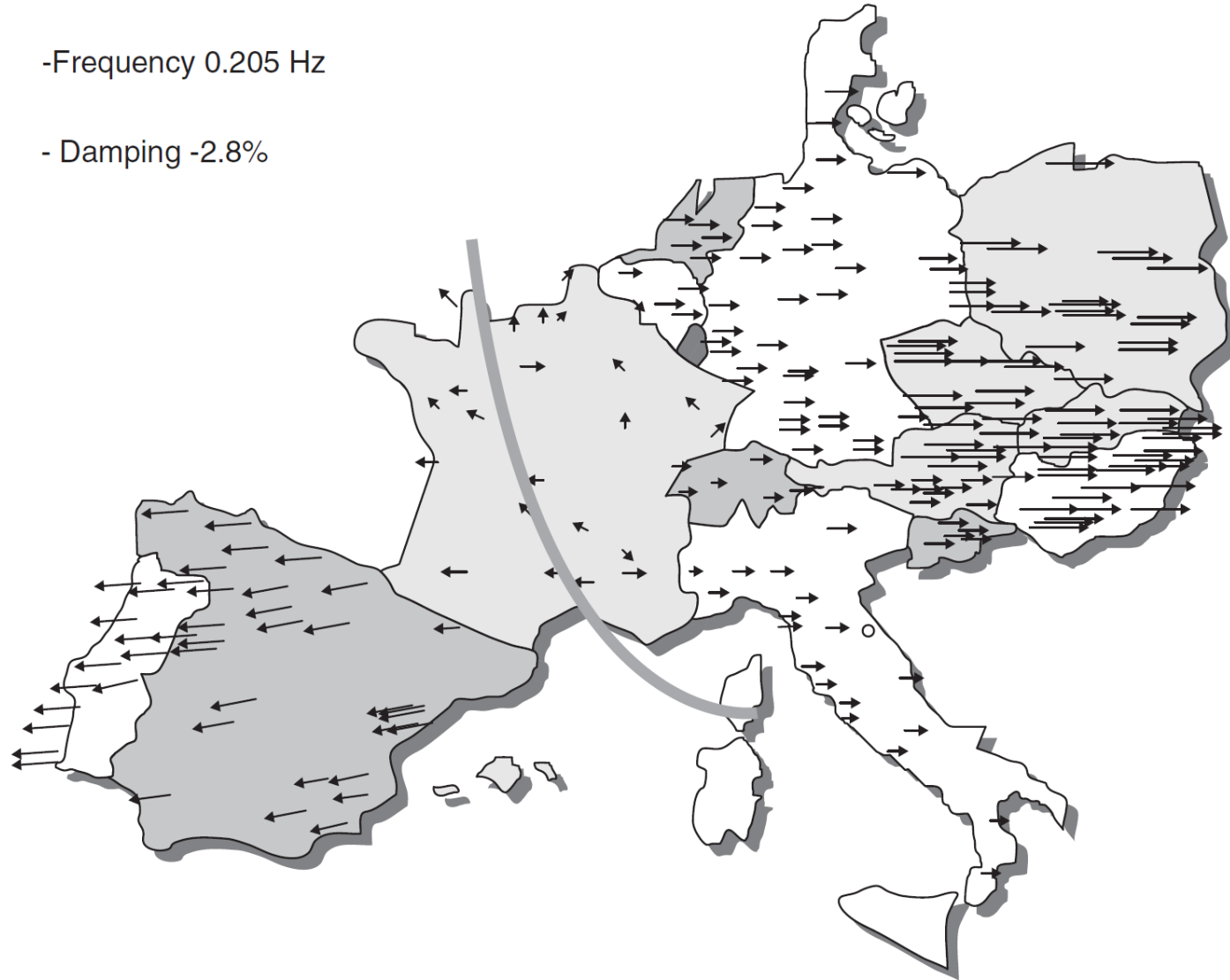

Small Signal Stability

Inter-area Oscillations of 1st December 2016

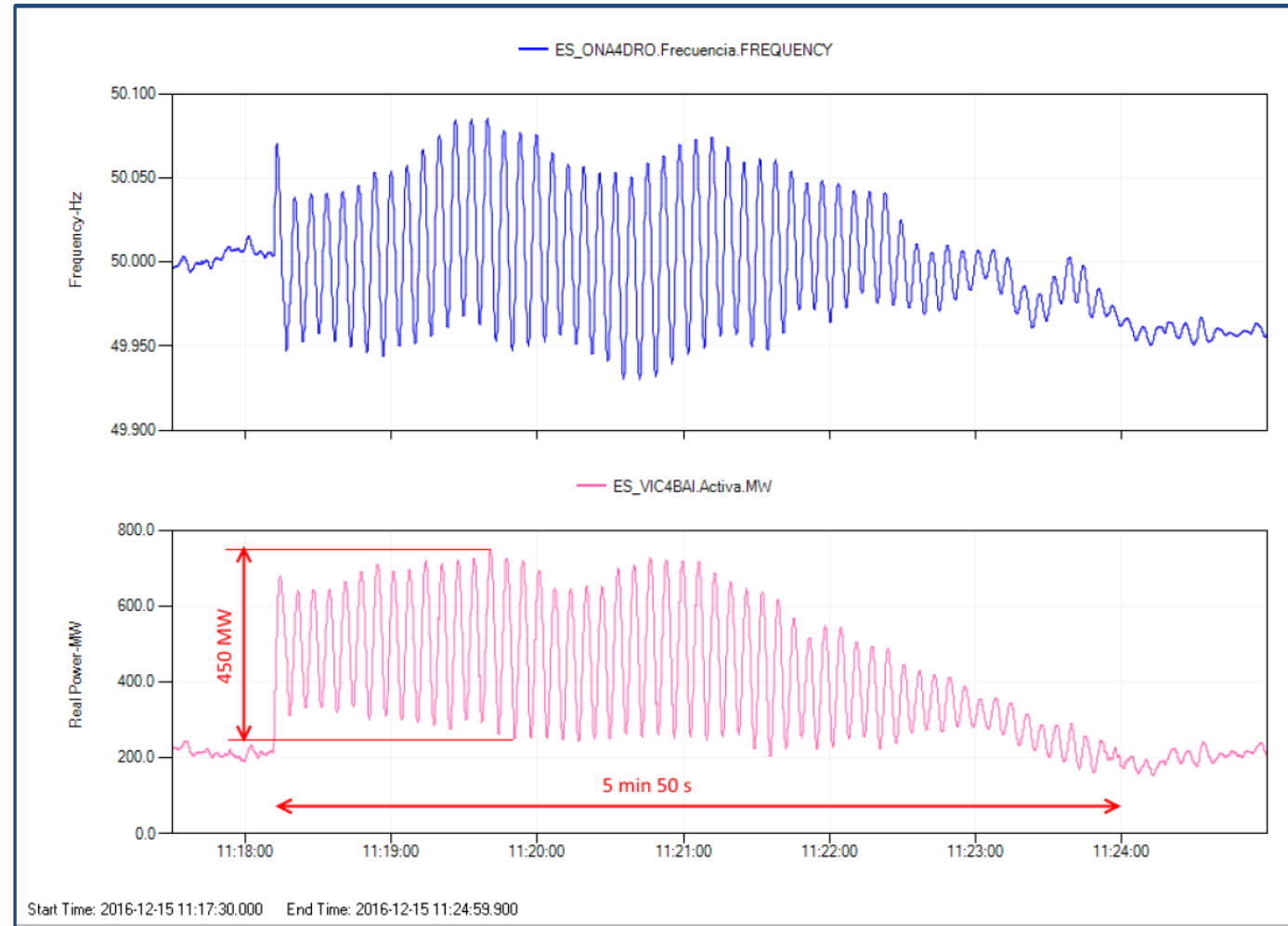
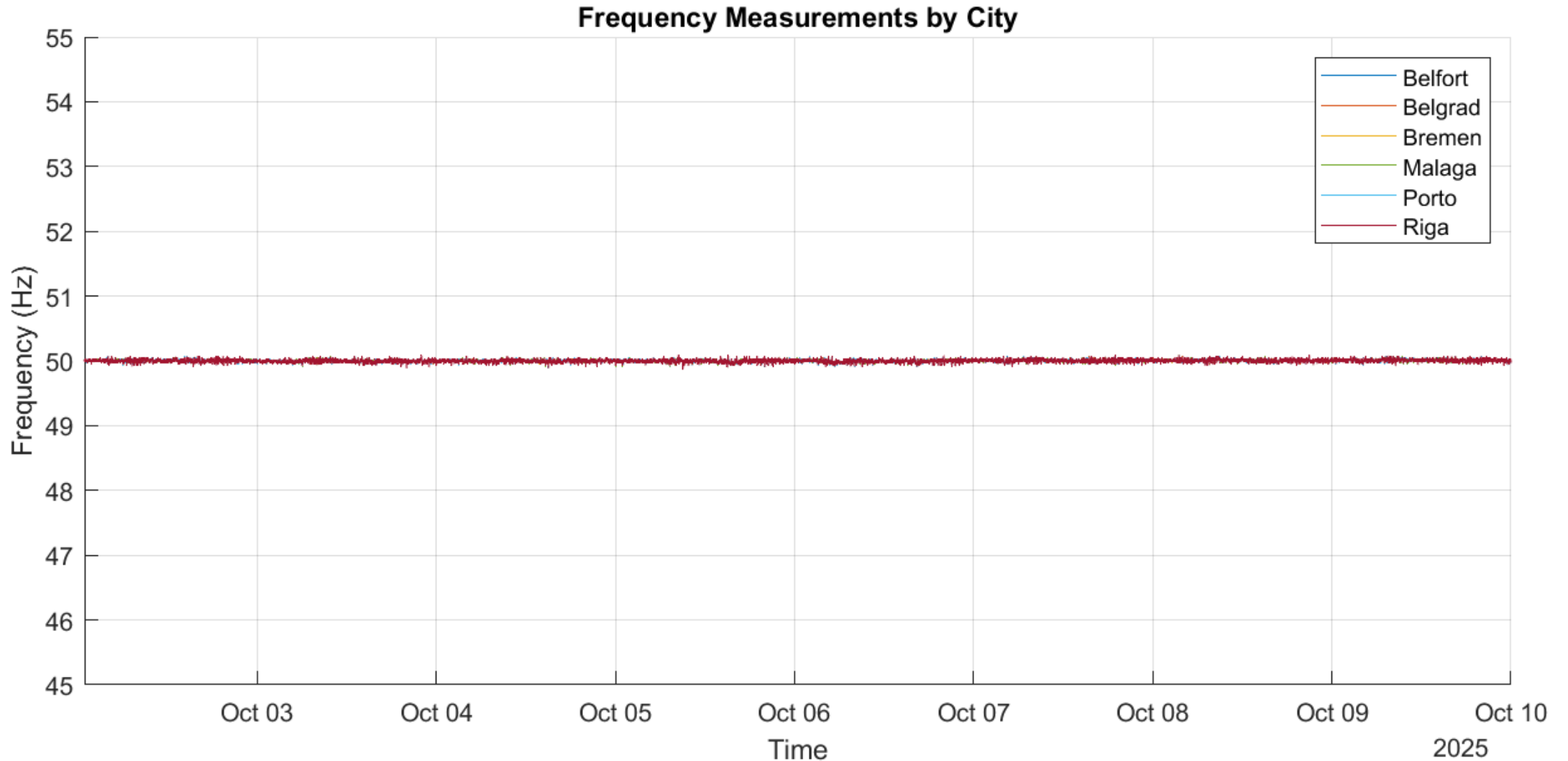

Figure 8. Frequency in Spain and active power through 400 kV Vic-Baixas tie line

Small Signal Stability

Frequency Measurements (4-10 October 2025)



Small Signal Stability

Frequency Measurements (3-10 October 2025)

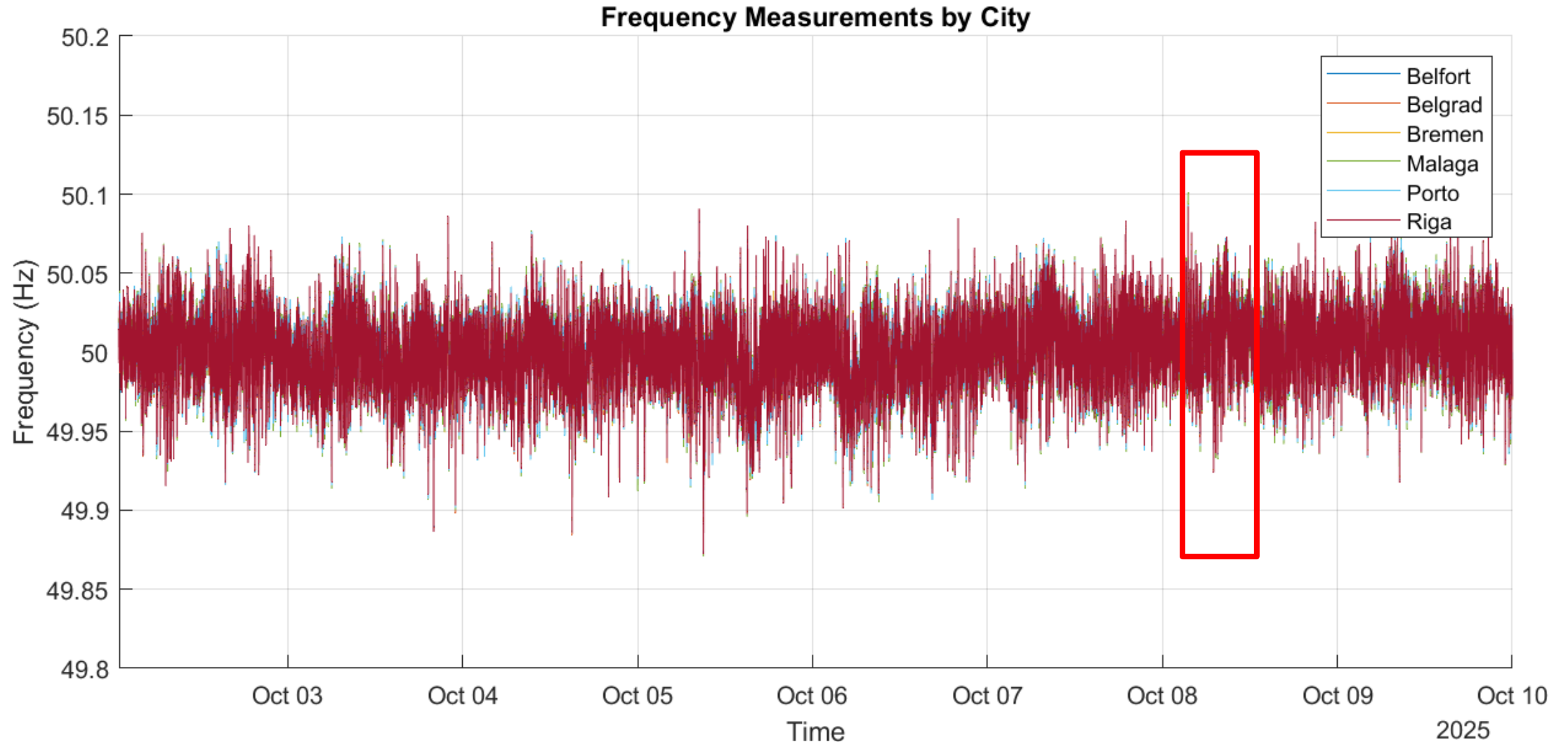

Small Signal Stability

Frequency Measurements (8 October 2025)

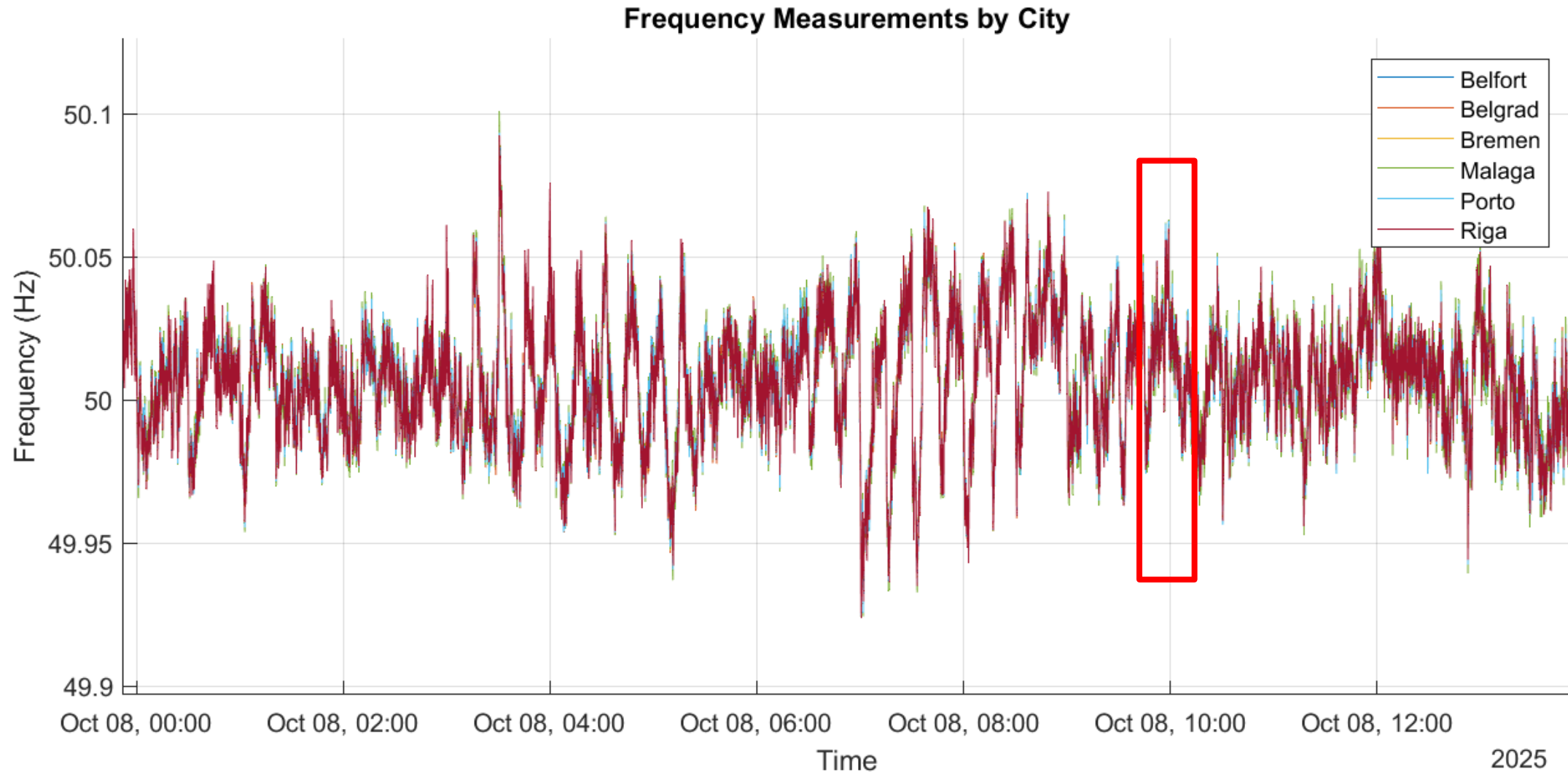

Small Signal Stability

Frequency Measurements (8 October 2025)

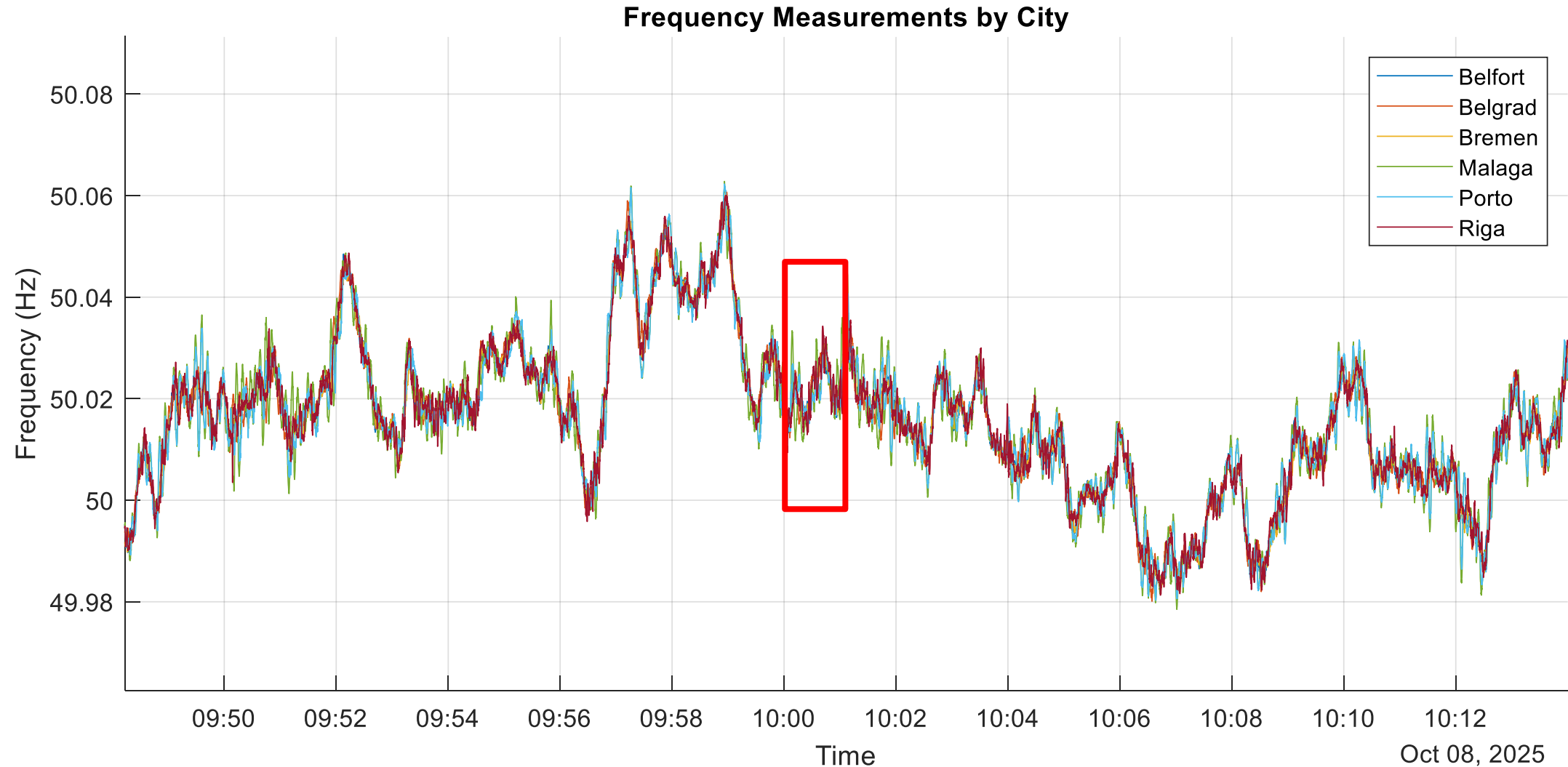

Small Signal Stability

Frequency Measurements (8 October 2025)

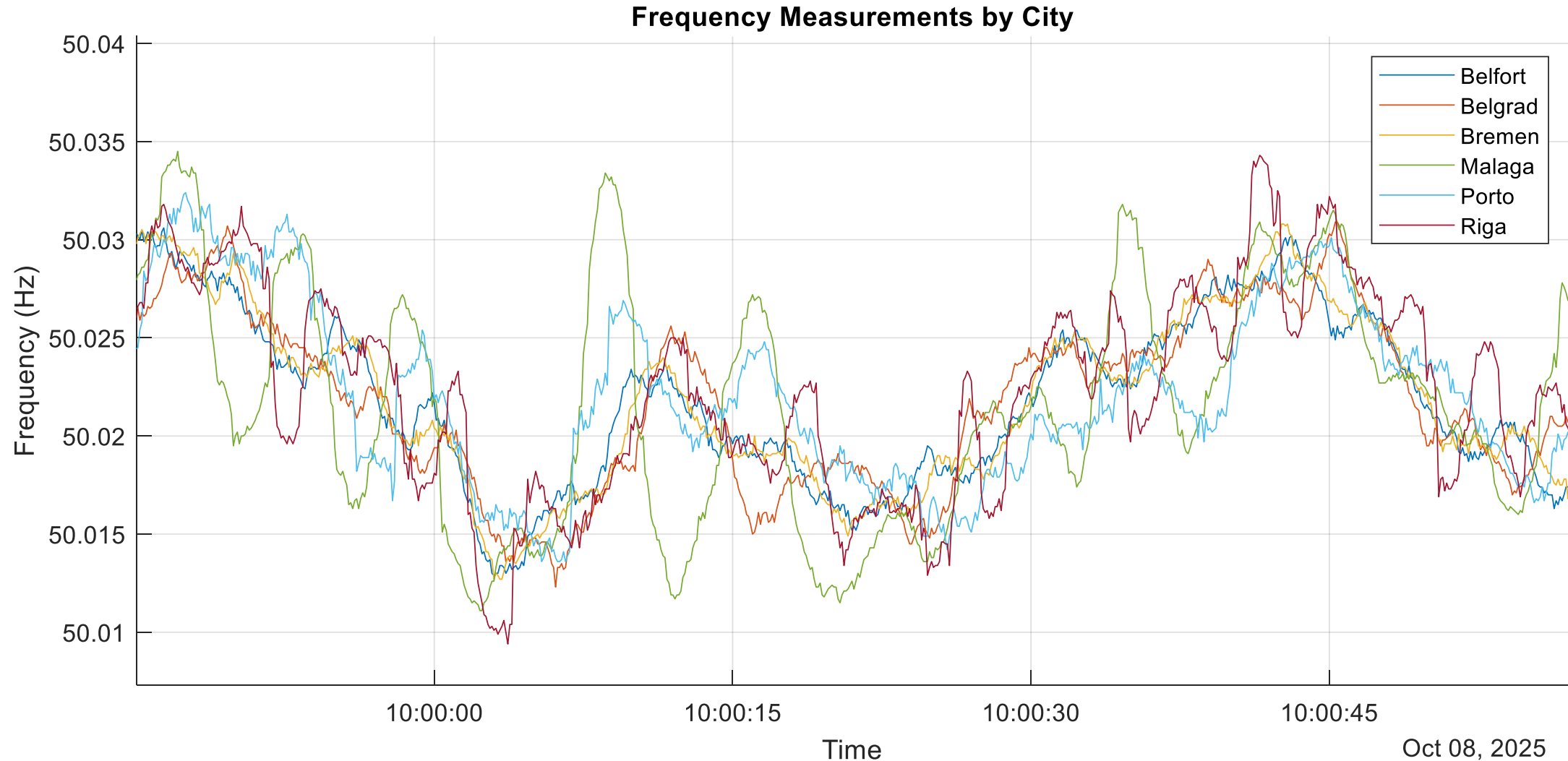

Solutions?

1. Reinforcement of the tie-lines (especially Spain-France)
2. Re-tune of the present PSSs
3. Grid-forming control for renewable generations: dynamic voltage stability controller^(1,2) and PSS
4. Blackstart capability: hydropower plant, gas turbines, battery storages and renewable generations⁽³⁾

(1) L. Cai, and I. Erlich, "Dynamic Voltage Stability Analysis in Multi-machine Power Systems", Paper published in 15th Power Systems Computation Conference, August 22-26, 2005, Liège, Belgium.

(2) L. Cai and I. Erlich, "Identification of the Interactions among the Power System Dynamic Voltage Stability Controllers using Relative Gain Array (RGA)", Paper published in Power System Conference and Exposition, Oct. 29 – Nov. 1, 2006, Atlanta, USA.

(3) <https://www.wemag.com/aktuelles-presse/wemag-batteriespeicher-testet-erfolgreich-schwarzstart-nach-blackout>

Solution: PSS in Renewable Generations

1. VSC-HVDC grid forming control
 2. Grid forming control of a large PV park
 3. Grid forming control of a large wind farm
- } Single large converter
- How many turbines should be grid forming and how many grid following?
 - Which grid forming control should master and which are slaves?
 - ...

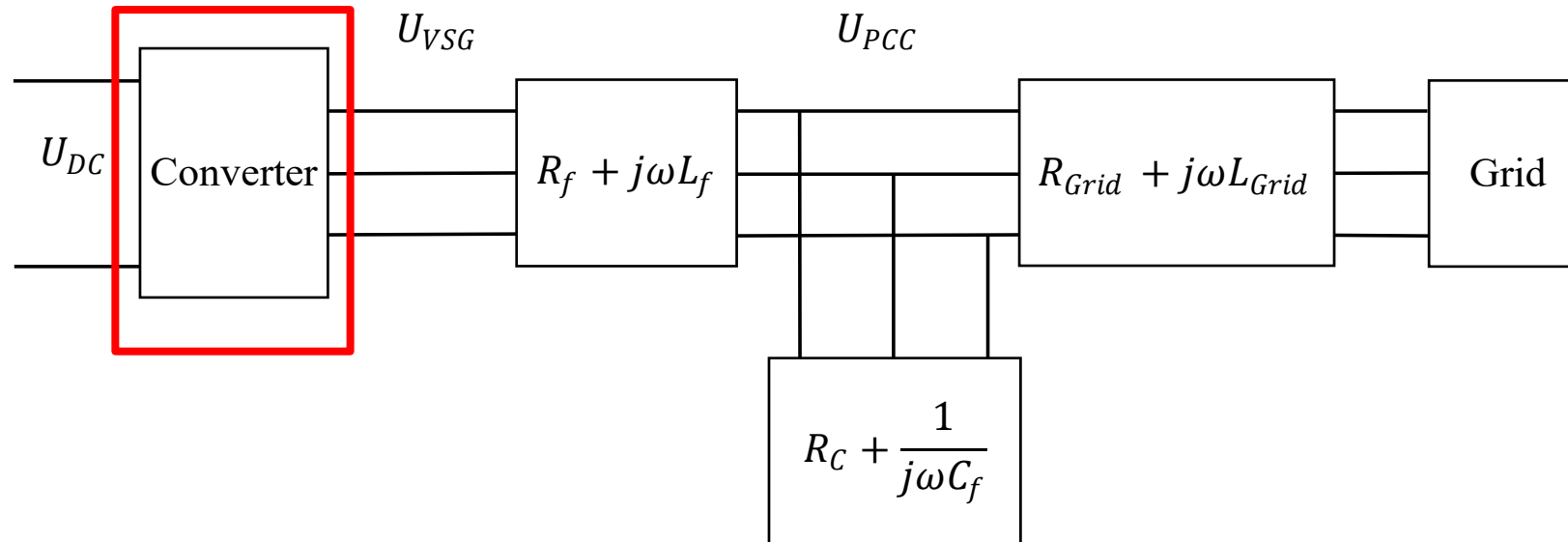

Solution: PSS in Renewable Generations

Grid Forming Control

51

1. Droop control (P/f- and U/Q-droops)
2. Distributed virtual oscillator control (dVOC)
3. Matching control (MC)
4. Virtual synchronous generator (VSG) control

Solution: PSS in Renewable Generations

Virtual Synchronous Generator (VSG) Control

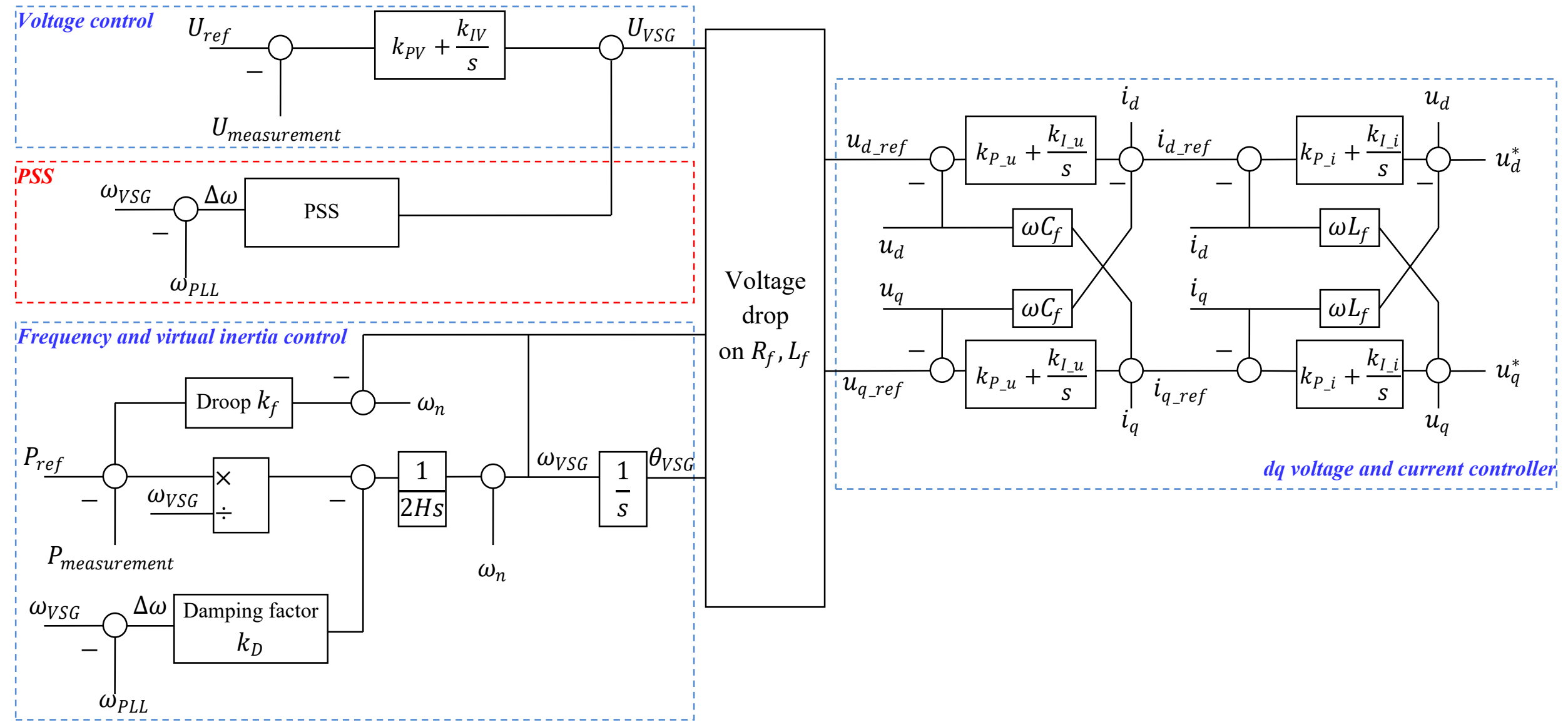

Solution: PSS in Renewable Generations

PSS Structure

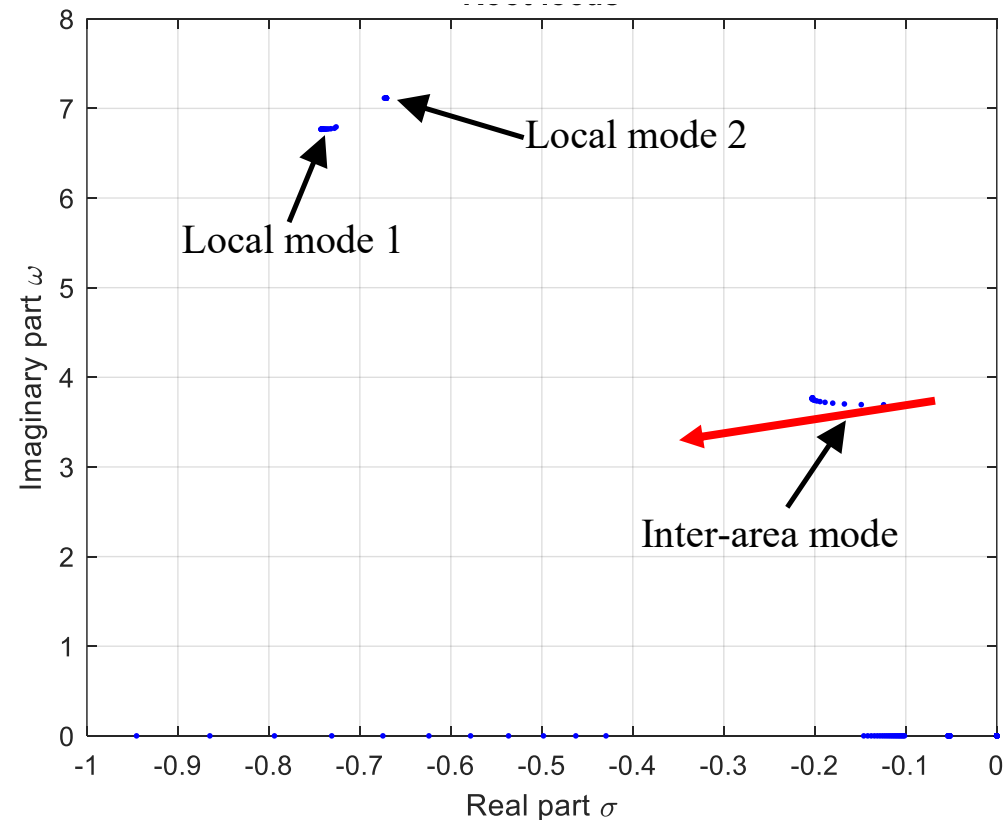
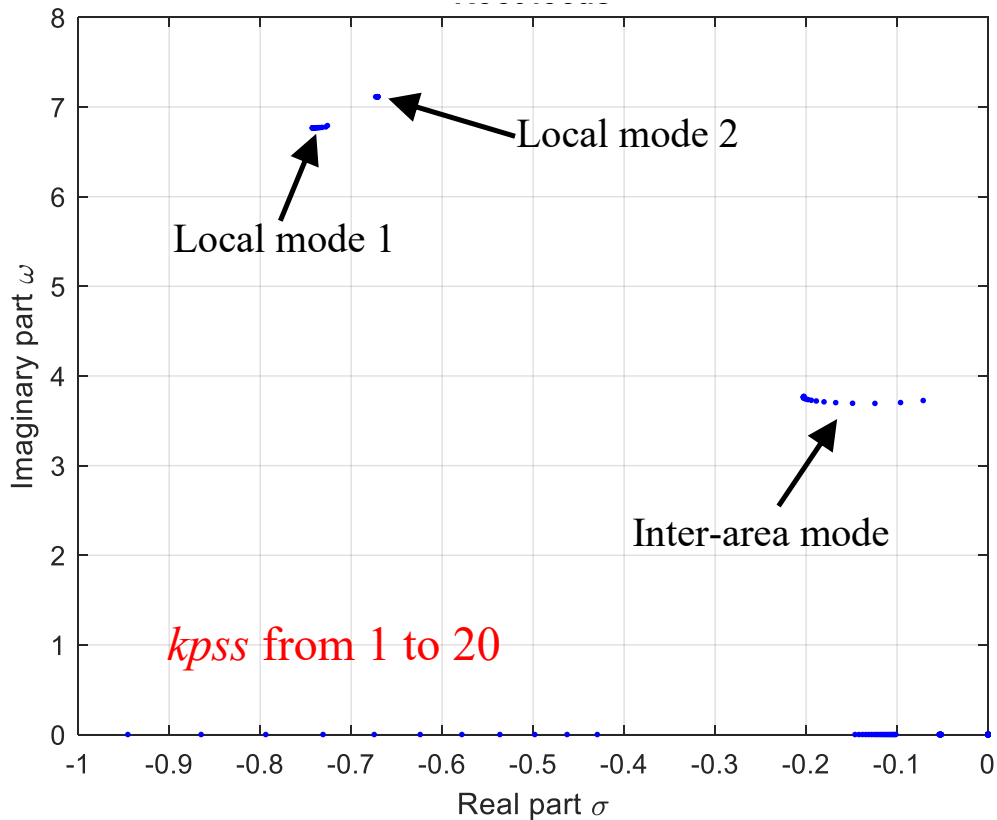
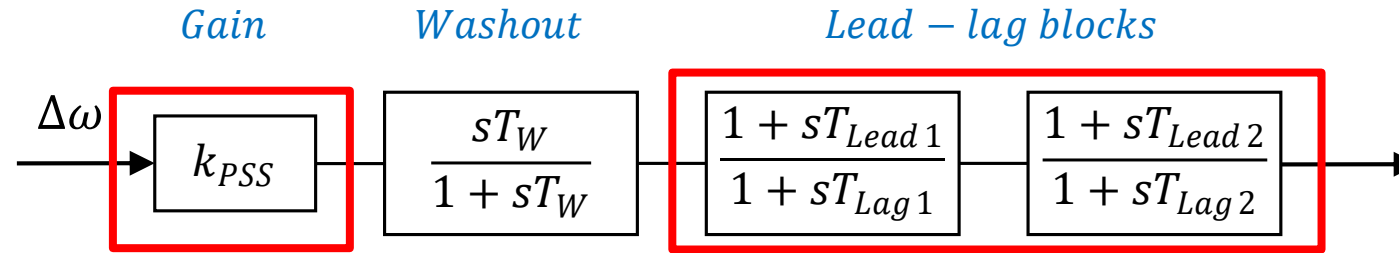

Solution: PSS in Renewable Generations

Power System with VSG-PSS

Power system model (modified Kundur system)

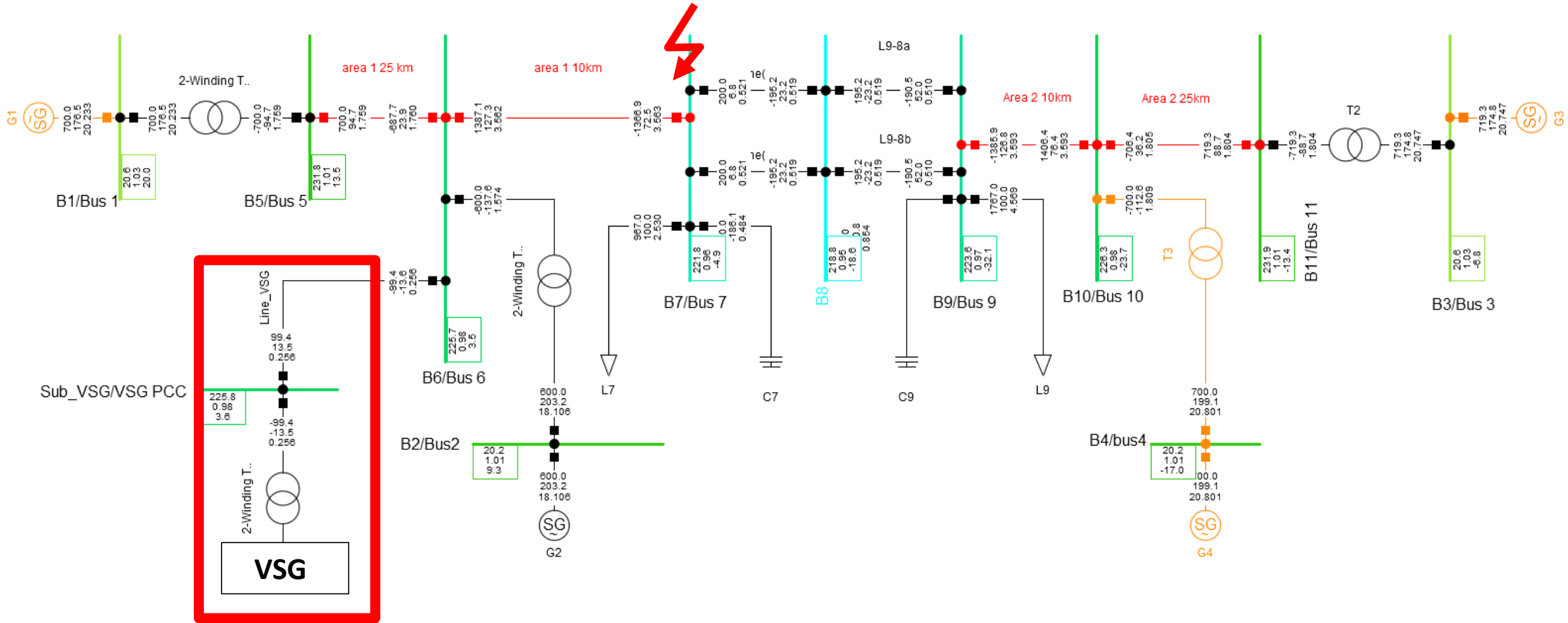

Solution: PSS in Renewable Generations

Simulation Results

55

Generator angles

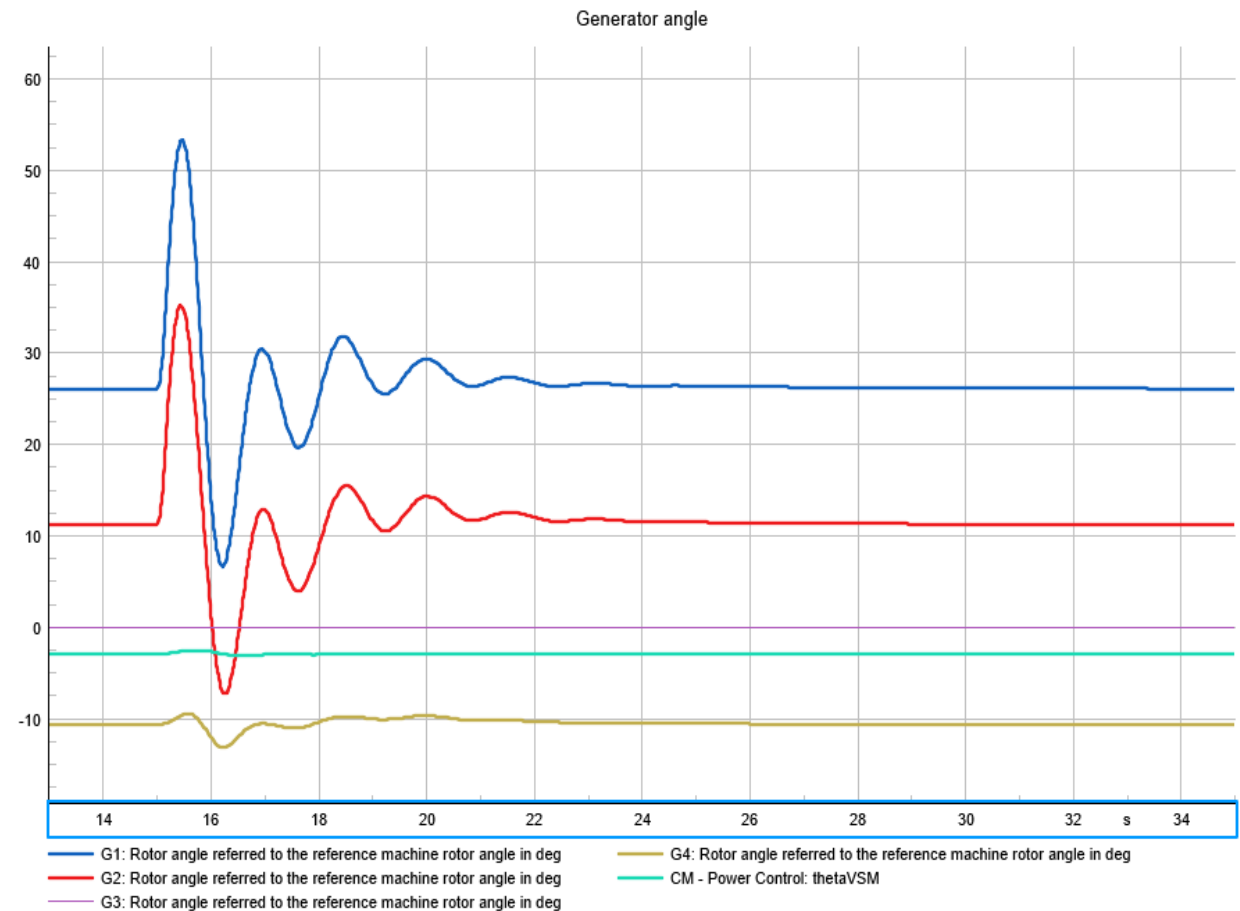
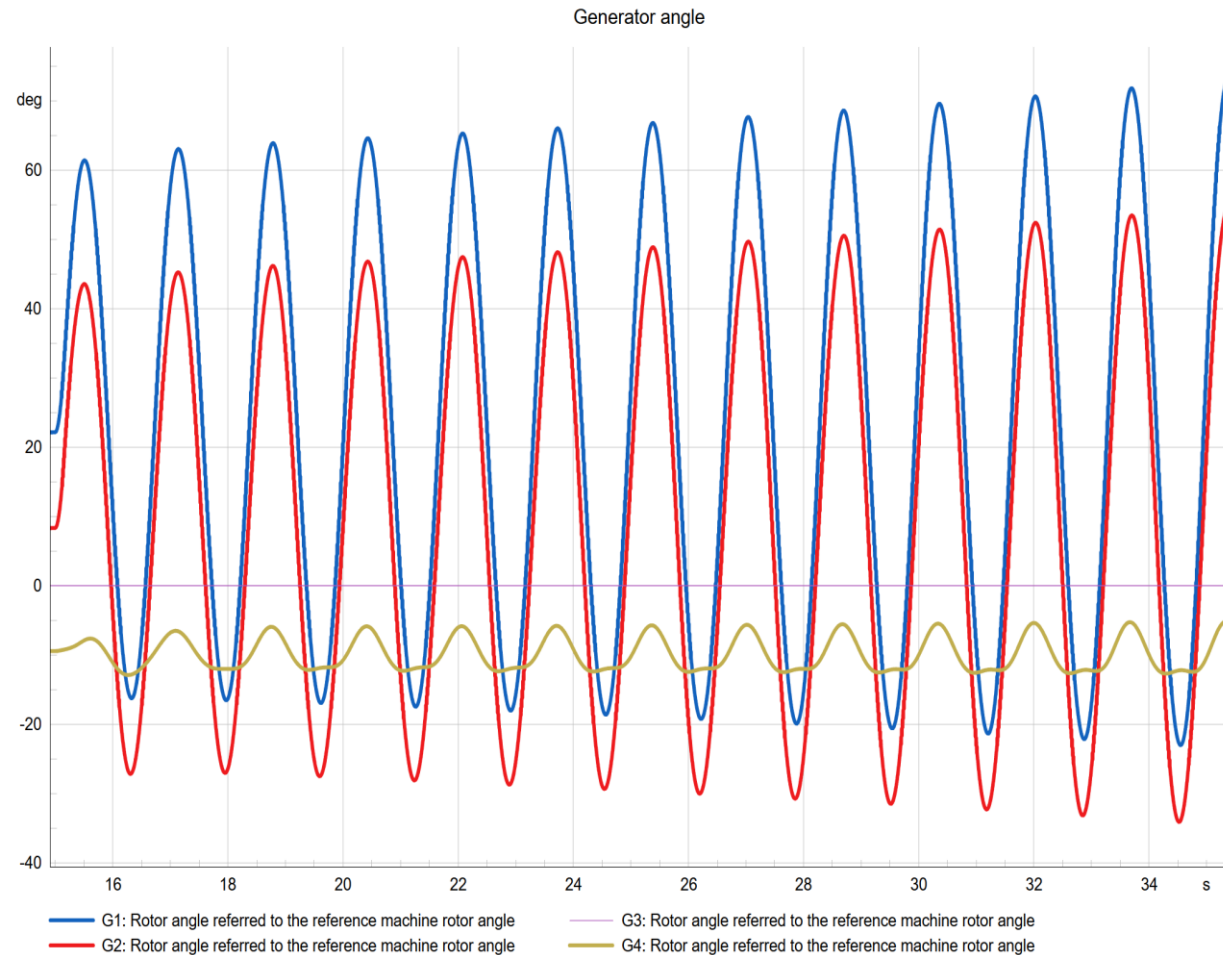

Conclusion and Future Work

1. Conclusions

- **VSGs can effectively participate/damping in inter-area and local mode of oscillations**
- **VSG control capability: the ability of VSGs to emulate inertia and incorporate PSS functionality makes them valuable for maintaining angle stability in systems with reduced synchronous generation**

2. Future work

- **Grid forming control in large wind farms**
- **PSS design in large renewable dominated power systems: re-tune of present PSSs (on synchronous generators), coordination of VSG-PSSs, etc**

Thank You for Your Attention!

In memory of:

**Prof. István Erlich
Dr. Prabha S. Kundur
Dr. Graham Rogers**

Grid forming requirements on loads:



Technische Anforderung für den Anschluss von Elektrolyseanlagen

Technical requirements for the connection of
electrolyser facilities

February 2024