

December 16, 2025 Virtual Meeting

IBR Plant Commissioning Best Practices II (~180 attendees)

Presentation recording and slides are available to download [here](#). Figure 1 shows the makeup of meeting attendees by industry sector:

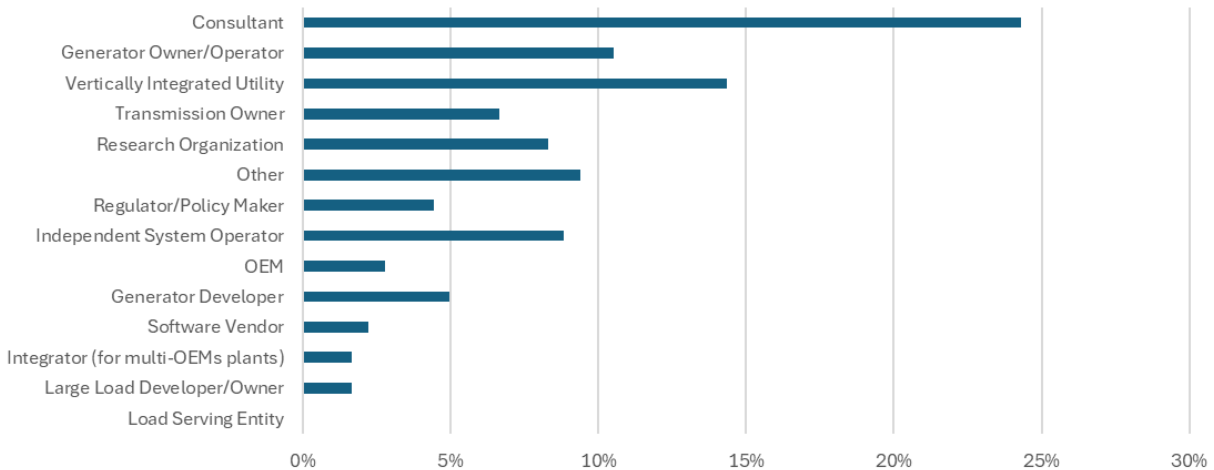

Figure 1: Meeting attendees by industry sector

This eighth meeting of Season 2 of the DOE i2X FIRST initiative focused on IBR plant commissioning best practices and experience from developers, OEMs, and system operators. IBR plant commissioning is the process configuring, integrating, testing, verifying, and validating that the equipment is installed correctly performs as required when connected to the grid. Its purpose is to demonstrate safe, reliable, and compliant operation before commercial operation is declared. Commissioning consists of a sequence of events that occur over a relatively short time period following construction and prior to COD. The process involves multiple parties and integrates prior interconnection process phases such as interconnection requirements, interconnection and modeling study results, OEM equipment acceptance testing, etc.

Once equipment is installed, site commissioning begins and is usually performed in a staggered manner for large IBR facilities. Initial activities may occur prior to energization such as “cold commissioning” which focuses on controls, communications, protection, and telemetry. As portions of the plant are energized, additional grid-connected “hot” testing is performed at increasing power levels. Plant-wide testing and final validation typically involve coordination with, and sometimes formal acceptance by, the transmission owner or grid operator.

Commercial operation occurs only after commissioning is complete and required performance has been demonstrated. The time between initial testing and commercial operation can range from weeks to months depending on project size, complexity, and regulatory requirements.

Presentations from this session included the following:

Zach Hammond and Rishi Maharaj, Engie

Zach and Rishi shared typical mandatory field commissioning tests for IBR plants in North America as well as observations, experience, and recommendations regarding these tests. IBR plant commissioning plays a critical role in determining whether a facility will perform reliably once it enters commercial operation. Although commissioning occurs late in the development lifecycle, it represents the final opportunity to verify and validate plant controls, protection systems, and operational behavior align with interconnection requirements and system reliability needs. Despite its importance, Zach and Rishi highlighted that commissioning practices across North America remain highly inconsistent.

Mandatory commissioning requirements vary widely by region and applicable grid authority. Some regions impose detailed test definitions, review procedures, and approval processes, while others have minimal or no formal commissioning requirements at all. A lack of mandatory requirements should not be interpreted as an indication that robust commissioning is unnecessary. Levels of oversight also vary significantly, ranging from active review and approval of test plans and results to simple receipt of a declaration that testing has been completed. Since NERC registration and compliance obligations for Generator Owners are only triggered at commercial operation, attention to demonstrating compliance with NERC standards is often overlooked during commissioning. This means that IBR plants are often commissioned without the rigor later expected under the NERC MOD and PRC standards.

Typical commissioning tests for IBR plants include automatic voltage regulator (AVR) testing, primary frequency response (PFR), active power control and curtailment capability, and capacity testing for BESS. While these tests are commonly referenced, test methodologies, scopes, and acceptance criteria differ substantially across transmission entities. This variability leads to inconsistent expectations and plant behavior, even for similar technologies.

The following are brief explanations of some of the common tests performed:

- **AVR testing** is often performed using voltage reference set point step changes to confirm that voltage control within the continuous operation region is enabled and that reactive power responds in the correct direction. More comprehensive testing evaluates whether the plant can deliver its full reactive capability at the POI under specified conditions and within required response times. However, important operating modes such as voltage support at zero active power generation (e.g., night VARs for solar plants) or idle operation for BESS are rarely tested despite their relevance to real-world grid conditions.

- **PFR testing** is typically conducted by injecting or simulating frequency offsets within the PPC and observing the IBR plant's response. Deadbands, droop settings, and performance criteria are usually defined, and wind or solar IBR plants are often required to demonstrate overfrequency response only (i.e., underfrequency response from curtailed state is usually not tested) while BESS are expected to respond to both under- and overfrequency events.

Other less common tests such as in-plant contingencies, hardware and communication failures, large disturbance behavior testing, etc., are not often performed but can help provide useful insights into how the IBR plant will respond to these abnormal conditions.

The fundamental objective of IBR plant commissioning should be to understand how the facility behaves under grid events, not merely to demonstrate compliance with minimum requirements. Wherever possible, IBR plants should be subjected to challenging but safe test conditions to uncover failure modes and unintended interactions. Many scenarios cannot be fully evaluated through simulation testing alone. These include hardware failures, communications failures, invalid command handling, controller redundancy and fallback behavior, and system re-initialization following abnormal conditions. Grid operator requirements should be viewed as complementary to owner-driven testing, not as a substitute for it.

Care must be taken to coordinate tests with the transmission operator, but limiting testing to narrow scenarios increases the risk of unanticipated behavior during real grid events. Additional areas that warrant attention include validation of external measurement devices, testing of night-mode voltage regulation for solar plants, and evaluation of frequency response from curtailed state and using realistic, time-varying frequency signals.

Many modern IBR plants are supported by EMT models developed prior to commissioning, yet significant challenges remain in using these models to replicate field behavior. Measurement devices and associated time delays are often simplified or omitted. On load tap changer (OLTC) logic and shunt switching behavior are rarely represented accurately in the models and require measurement-based validation. Aggregation of collector systems can obscure terminal voltage behavior at individual inverters, and PPC models may not fully represent limiters, fallback logic, or priority schemes implemented in the field. As a result, models may satisfy interconnection study requirements while failing to demonstrate the as-left, commissioned configuration. EMT models are most valuable when they are actively used to inform commissioning rather than treated as static interconnection artifacts.

Differences between modeling assumptions and field implementations are often most evident during parameter verification. Reactive power limits are a common example. Models may use fixed gross MVAR limits, while PPCs apply MW-dependent, net-of-loss limits at the POI. Direct translation of parameters between these frameworks can result in unintended behavior and discrepancies between simulated and measured performance. Active power limits present similar challenges. Gross inverter capability represented in EMT models must be translated to net power

at the POI after accounting for collector system and transformer losses. Failure to understand these distinctions can lead to unexpected results during commissioning, even when parameters appear to be “approved.”

Minimum commissioning requirements should be treated as a baseline rather than a target. The effort and cost required to correct deficiencies increase dramatically as a project progresses, and commissioning represents the last relatively straightforward opportunity to address design and control issues. Accelerating commissioning by reducing test scope often results in costly rework during commercial operations, additional operational risk to the IBR plant owner/operator, and long-term reliability challenges. Detailed commissioning plans are essential for understanding plant behavior, even when individual components have been extensively validated, and is especially critical when they have not.

Lars Johnson, Merit Controls

Lars shared perspectives of a PPC manufacturer that also touched on SCADA integration and networking considerations. He highlighted that effective commissioning of IBR plants extends well beyond inverter controls and system performance requirements. Reliable IBR plant operation depends on the successful integration of PPCs, SCADA systems, communications networks, and various field equipment. From initial scoping through long-term operations, commissioning must be treated as an end-to-end process that validates not only electrical behavior, but also data integrity, control pathways, cybersecurity, and operational readiness (see Figure 2).

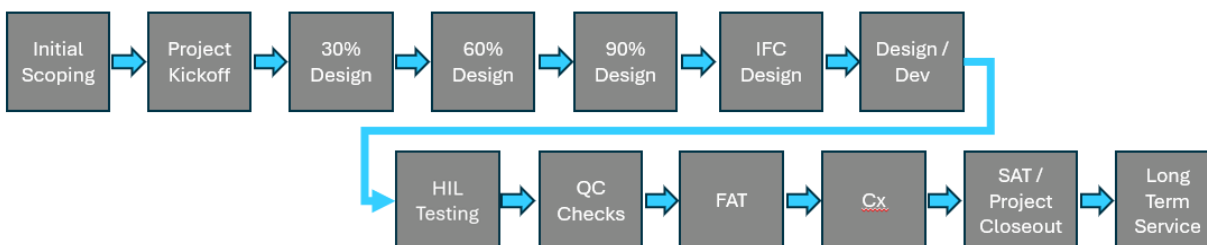

Figure 2: Overall Project Flow for IBR Plant PPC Design [Source: Merit]

A structured project lifecycle begins with initial scoping, during which project requirements are defined based on interconnection obligations, grid code requirements, equipment selections, functional features, and schedule constraints. These requirements flow into progressive design stages, typically at 30%, 60%, 90%, and Issued-For-Construction (IFC) levels, which serve as the foundation for system development and configuration. Design documentation captures control narratives, system architectures, data flows, network layouts, and test plans, providing a common reference for owners, integrators, and equipment vendors.

Early in the project lifecycle, integration meetings with inverter OEMs and other equipment suppliers are essential to clarify interfaces, communications protocols, data mappings, and

control requirements. For new or unfamiliar vendors, additional qualification activities are often required. These may include laboratory testing at the vendor's facility, point-to-point communications verification, setpoint and control testing, and characterization of inverter behavior through tests and emulator-based environments. These efforts reduce integration risk later in the project, including at commissioning.

System configuration builds upon standardized templates and automation, allowing project-specific parameters to be applied consistently across PPC logic, SCADA tag databases, network devices, and server infrastructure. Configuration activities include development of SCADA displays, I/O mappings, communication drivers, PPC parameter sets, and networking equipment configuration. Template-based approaches improve repeatability while allowing for site-specific customization.

Hardware-in-the-loop (HIL) testing is often used as additional quality assurance. Real-time simulation environments combining grid models, inverter models, and control system logic allow verification and validation of IBR plant response, particularly for scenarios that are not practical to test in the field (e.g., voltage and frequency ride-through events, faults, etc.). HIL testing supports early tuning of control parameters and validation of edge-case behavior prior to site deployment. EMT models of the PPC and master controller logic are maintained and updated throughout the project. These models are validated and benchmarked against phasor domain transient models and used to confirm consistent response to voltage, frequency, and setpoint changes.

Before equipment is shipped to the site, factory acceptance testing (FAT) is performed following internal quality control checks. FAT environments replicate the site architecture as closely as possible including SCADA servers, PPC hardware, network switches, firewalls, fiber networks, and plant emulators representing meters, inverters, trackers, etc. FAT validates networking and cybersecurity configuration and serves as a customer-witness activity confirming readiness rather than discovering new issues. Equipment is then shipped as fully integrated, pre-tested systems intended for quick field deployment.

Site commissioning proceeds in phases including, but not limited to, the following:

- **SCADA rack installation**
- **Field fiber network enclosure installation**
- **Cold commissioning** prior to energization to verify networking configurations, telemetry, data integrations with the utility and ISO(s), meter data quality and scaling, time synchronization, control point confirmation, etc. (see Figure 3)

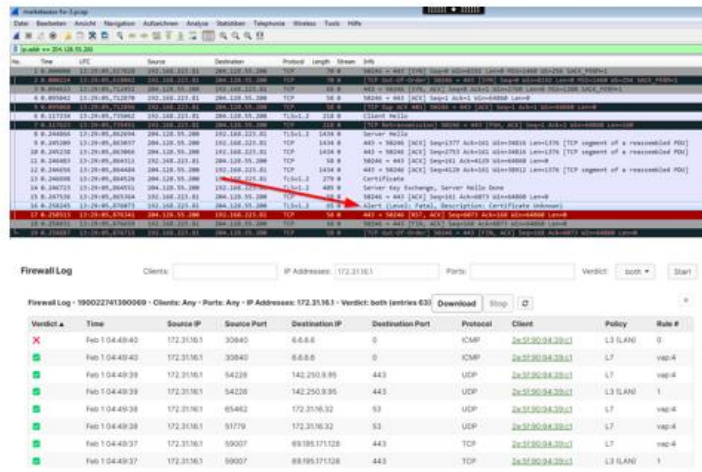
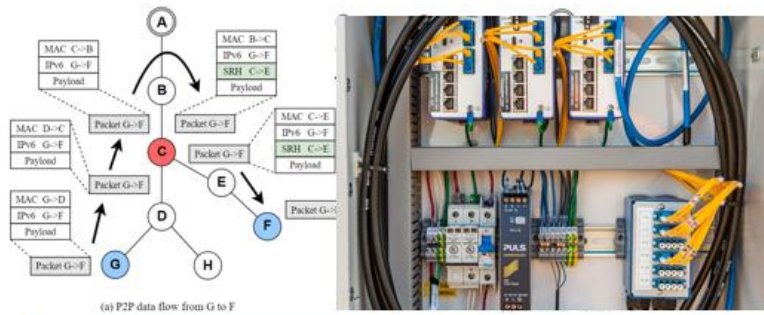

Figure 3: Visualization of Cold Commissioning Checks [Source: Merit]

- Hot commissioning** once initial test energy is available (typically less than 20 MVA connected to grid) including initial synchronization, live data verification, communications checks, validation of inverter and other auxiliary data, etc. Functional testing progresses from manual start/stop commands and active and reactive power set points to closed-loop automatic control within defined limits. Plant metrics, counters, aggregation logic, and high sustained limit (HSL) calculations are verified, along with telemetry delivery to external entities. Data logging functions required for standards and reliability reporting are confirmed.
- Site acceptance testing (SAT)** is performed once confidence in the integrated system has been established. SAT validates plant-wide manual and automatic controls, capacitor bank integration, aggregate active and reactive power performance, and overall system stability. Response tests against established performance requirements are often performed at this phase. SAT is a contractual milestone and precedes, rather than replaces, ISO or utility commissioning tests, though overlap may occur.
- Coordination with the transmission operator, ISOs, and site commissioning managers** is often needed for large power changes and full capability testing. These tests may include full-power and zero-power operation, ramp rate verification, PFR response, power factor capability testing, four-quadrant operation for BESS, and automatic voltage control. Voltage step tests may be initiated through controller setpoints, simulated

measurements, or utility-driven network changes. Remote control and telemetry tests are often conducted concurrently to validate external commands.

- **Retesting** may be needed if grid conditions are restrictive and limit testing procedures – this is sometimes unavoidable. Grid voltage conditions, equipment outages, unavailable capacitor banks, insufficient inverter availability, telemetry errors, or misunderstandings of utility acceptance criteria can all necessitate additional (re)testing. Weak grid conditions further increase the likelihood that tests will not pass on the first attempt, requiring tuning or other workarounds.
- Formal handoff to operations involves delivering final documentation, SAT reports, model validation data, and recording of final “as-left” parameters. Training is provided for operators and operations and maintenance teams, and remote access arrangements are transitioned to long-term service providers.

Several recurring challenges have emerged across IBR plants. Scheduling disruptions caused by construction delays, weather, and shifting priorities can complicate resource planning and coordination. Compressed timelines with fixed commercial operation dates increase risk. Issues outside the PPC or SCADA scope (often related to third-party equipment or site infrastructure) frequently surface during commissioning and must be resolved before progress can continue. Weak grid conditions, late-emerging requirements, and discovery of design gaps late in the project further increase complexity.

Experience consistently shows that early preparation, thorough requirements gathering, extensive pre-deployment testing, and disciplined commissioning practices are essential for success. Addressing integration, controls, and network challenges early in the project lifecycle significantly reduces rework, delays, and operational risk once the IBR plant enters service.

Phillip Hiusser, Independent Electricity System Operator (IESO)

Phillip shared ISO perspectives regarding IBR plant commissioning and checks that the transmission provider can do to verify and validate the performance of newly connecting IBR plants. Commissioning IBR plants is a critical component of the connection assessment and approval process in Ontario and designed to ensure that new IBRs enter service without introducing reliability risks to the grid. Growing levels of IBRs in Ontario are increasing the importance of robust commissioning processes that verify performance, validate models, and confirm operability before facilities are approved to connect.

Figure 4 illustrates a high-level connection review process used by IESO. The connection process begins with preliminary assessments based on proposed equipment ratings, capabilities, and models. At this stage, models are often hypothetical or based on typical parameters, and numerous assumptions are required to assess compliance with technical requirements. As a result, conclusions drawn during early studies are inherently tentative, and approval to connect is conditional on successfully demonstrating performance during commissioning.

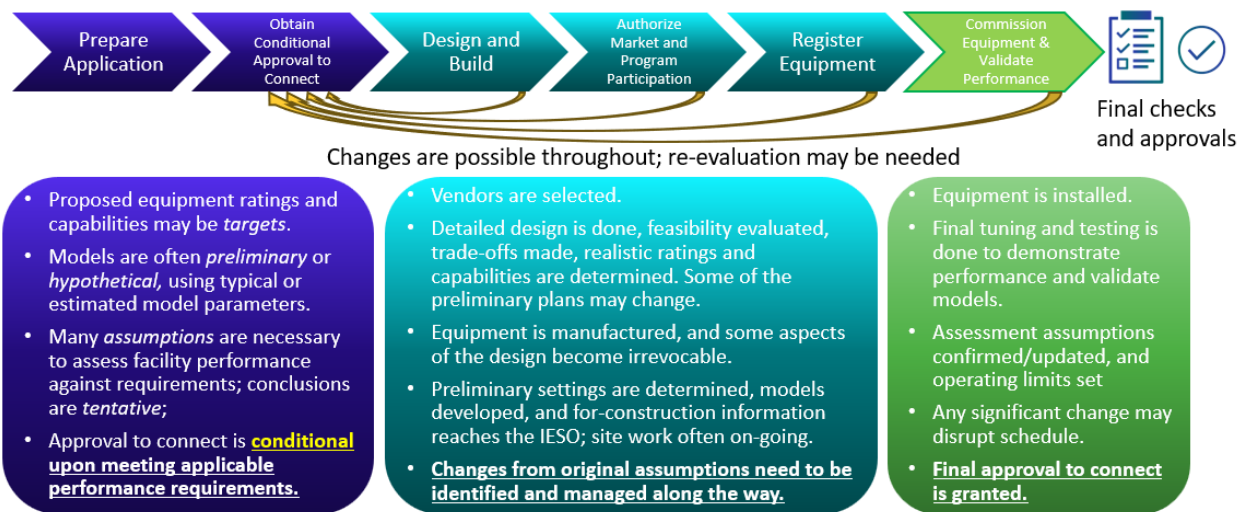

Figure 4: Connection Process and Conformity Checks in Ontario [Source: IESO]

As projects progress, vendors are selected and detailed designs are finalized. Equipment capabilities are refined, trade-offs are evaluated, and realistic ratings are established. Some aspects of the design become fixed once equipment is manufactured, while others remain adjustable through configuration and tuning. Preliminary settings are developed, models are updated, and for-construction information is submitted. Throughout this phase, deviations from original assumptions must be identified, tracked, and managed to avoid late surprises.

Once equipment is installed, commissioning activities focus on final tuning, testing, and demonstration of performance. Test results are used to confirm or update earlier assumptions, establish operating limits, and validate models. Significant changes at this stage can disrupt schedules, underscoring the importance of early alignment between studies, design, and expected field behavior. Successful completion of commissioning leads to final approval to connect.

Commissioning workflows involve coordinated responsibilities between applicants and the system operator (see Figure 5). Commissioning guidelines are used to demonstrate compliance with applicable NERC, Northeast Power Coordinating Council (NPCC), and market rule requirements, while project-specific requirements may be identified during interconnection studies and carried forward into IBR plant commissioning. Because IBR plants are complex, additional testing or data submissions may be required to confirm operational behaviors such as switching sequences, start-up and shut-down behavior, and responses to equipment failures.

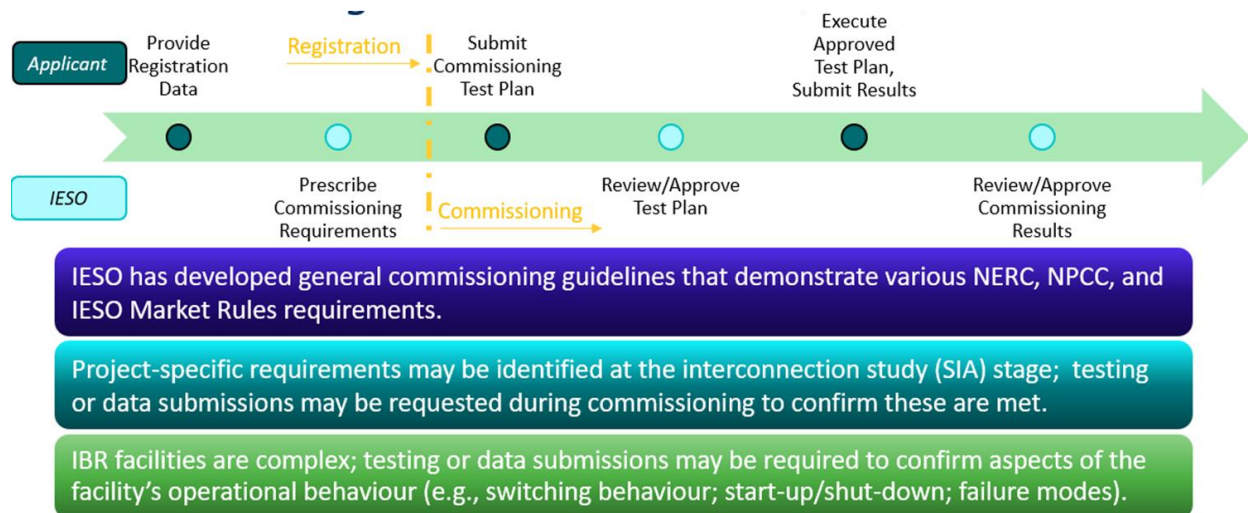

Figure 5: Commissioning Workflow in Ontario [Source: IESO]

The overarching objective of commissioning is to 1) ensure equipment connected to the grid has the performance required to maintain reliability (meet applicable requirements and not exhibit objectionable behavior), and 2) show the models and other data provided to IESO accurately reflect the site and support IESO planning and operations decision making processes. Both objectives are equally important, as accurate models are essential for anticipating system behavior beyond the specific conditions tested in the field.

Performance and model confirmation rely on a combination of benchmarking, verification, and validation. Benchmarking compares positive-sequence dynamic models (generic and user-defined) against validated EMT models. Verification focuses on ensuring that final “as-left” configurations and settings are accurately reflected in models, using evidence such as configuration files, screenshots, photographs, and documented parameter values (see for verification check examples). Validation involves direct comparison of measured responses from staged tests or ambient operation against simulated responses to confirm acceptable agreement.

Steady State and Dynamic Capabilities and Models	Protection System Checks	Other Common Checks
<ul style="list-style-type: none"> • Real & Reactive Power Capabilities • Reactive Power/ Voltage Control Performance • Active Power/ Load Control Performance • Power Flow models • Dynamic models • EMT models 	<ul style="list-style-type: none"> • Coordination • Ride through • Loadability • Security during recoverable swings • NPCC Design Criteria • Trip timing • Reclosing behaviour • RAS performance (timing) 	<ul style="list-style-type: none"> • Reactive device switching • Responses to abnormal conditions, such as: <ul style="list-style-type: none"> • loss of transmission supply, • loss of service supply, • loss of communications, • etc. • Islanding behaviour • Start-up/shut-down behaviour (timing) • Disturbance Monitoring Equipment (DME) functionality and configuration

Figure 6: Examples of IBR plant Verification Checks [Source: IESO]

Key observations and recommendations IESO has collected over the years include the following:

- **Managing requirements is a recurring challenge.** Applicable obligations arise from numerous sources, including reliability standards, market rules, interconnection studies, protection requirements, and transmission-specific criteria. These requirements are often complex and region-specific. Process complexity should be minimized where possible, and developers benefit from clear guidance on expectations and common pitfalls. Successful projects typically employ systematic processes to track requirements to completion, engage experienced vendors and service providers, and maintain frequent, clear communication with relevant authorities.
- **Project scoping and scheduling present additional challenges.** Ambitious commercial operation dates often conflict with the sequential nature of interconnection and commissioning processes. Site construction is rarely the final step before commercial operation, and failure to account for remaining dependencies can result in unrealistic schedules, time pressure, rework, or compromised technical scope. Clear articulation of process steps and timelines, combined with realistic scheduling and active management of schedule changes, improves project outcomes.
- **Change is inevitable during commissioning.** Unforeseen issues frequently arise, particularly in weak or complex grid conditions or under unusual operating scenarios. While digital control systems offer flexibility to address such issues, changes can invalidate prior assumptions and introduce unintended consequences. EMT studies are especially valuable for identifying potential oscillations or performance problems under reasonably foreseeable conditions. Effective change management requires clear documentation, defined communication protocols, and guidance on which changes necessitate re-studies. Ensuring resources are available to update analyses when needed can significantly reduce delays.
- **Fundamental engineering discipline plays a critical role in commissioning success, particularly with respect to base values and unit consistency.** Power system analysis relies on numerous per unit base quantities, including those embedded in controllers, relays, transformers, facility ratings, and simulation models. Mixing quantities on different per unit bases is common and can easily lead to errors. Best practices include explicitly documenting per unit bases, listing values in engineering units as well as per-unit or percentage form, confirming the reference base for all normalized values, and minimizing manual calculations through automation. Attention to related pitfalls such as primary versus secondary measurement quantities and phase versus phase-to-phase measurements is equally important.

Together these practices reinforce the role of IBR plant commissioning as a critical reliability stage gate. Thorough performance testing, disciplined model validation, proactive change

management, and strong engineering fundamentals are essential to ensuring that IBR facilities integrate successfully into Ontario's evolving power system without introducing avoidable operational or reliability risks.

Q&A and Interactive Group Discussion

How common is it that the studied/modeled parameters used during the interconnection process get implemented in the field during commissioning without any modification? Is it more common that generic PPC/IBR unit parameters are installed and models need to be updated?

This issue does occur quite often, and it is important to test the entire IBR plant as a whole system. OLTC settings, capacitor bank switching logic, hybrid plant configuration and controls, communications network latencies and delays, etc., all require additional testing during IBR plant commissioning. Capacitor banks are very commonly custom-implemented for the specific site and thus lack standardized design and settings. Thus, this becomes an integration challenge with the OLTC and PPC in terms of deadbands, dwell times, and other settings. Sometimes, the IBR plant must be detuned to handle these considerations.

In general, some model updates are almost always required. This is especially true once the IBR plant is connected to the actual grid. Fundamental limitations of simulation models prevent 100% accuracy. However, it is important not to "start from zero" in this effort. Maintaining models as accurately as possible throughout the interconnection process can help ensure that the starting point for commissioning-based true-up is closer to the actual and therefore less likely to cause delays in commercial operation.

Can you share the process of getting models updated around commissioning and COD? What happens when models do not match reality? Is COD delayed? Or are models updated after COD? How is this managed during this crunch time?

IESO shared that commissioning is completed once fully verified and validated models (based on commissioning testing) are attained. At least the settings and expectations for the IBR plant models should be agreed to at this point. There may be some lingering paperwork to true up documentation after COD. It is rather common for last-minute re-studies to be performed with the updated parameters/settings, and these are required before COD is achieved for the IBR plant. Changes need to be evaluated before COD; however, IESO allows for some documentation to be updated later.

Lars shared that escalations with very fast timeframes near the end of commissioning are quite common but did recognize that the changes are usually rather small in terms of impact to the site and models.

Engie agreed that the timelines are quite compressed and that updates often do occur after COD, if at all. In jurisdictions where a parameter verification report is not required, it is most common

that anything that changed during commissioning will not be reflected back into the models. The models get submitted but no changes are reflected. Often times, the “as-built model” is just resubmitting the old model and the checks completed on the transmission owner/operator side are inadequate to flag these issues.

Updating the models during commissioning may be very challenging and cause long delays; however, getting accurate and verified models is important. If no one is overseeing this aspect of commissioning, it is often overlooked in the interest of reaching commercial operation on time. The closer the pre-commissioning model can be to reality, the easier it is to work through this process of change effectively.

It was mentioned that overfrequency response for wind/solar IBRs is checked (operating with no headroom) but should underfrequency be checked for wind/solar to ensure it behaves correctly to max available power? What about curtailed operation to verify performance if ever curtailed?

It is good practice to test PFR across all operating conditions and in both directions, including PFR behavior during curtailment. This should also be tested at different active power operating conditions for wind resources, in particular. It can be rather difficult to get a conclusive response from OEMs on this topic and thus should be adequately tested.

It is important to ensure that the EMS system is operating correctly. ERCOT published resources regarding issues with the HSL, and transition between curtailed and non-curtailed operations can also be problematic with the PPC. These are rather easy things to test in the field, but difficult to test in a laboratory environment.

For AVR testing, what tests should be conducted to verify the combined response of the PPC, shunt devices, and OLTC, as this equipment does not activate at the same time?

This can include a combination of static and dynamic tests. In terms of static tests, this can include reactive power capability testing of the IBR plant at the POI, exercising equipment at various voltage levels, moving OLTC tap positions across a range of voltages, etc. From a dynamic test perspective, this includes voltage reference step changes, switching shunt devices in and out of service, measuring stability, overshoot, damping, etc. In some cases, the OLTC settings may be slow and coordination with the PPC may not be a factor; in other cases, the OLTC may operate in more dynamic timeframes and need closer coordination.

Longer-term testing of changes in terminal conditions can watch the overall longer dynamics of the IBR plant move to new set point values, which may not be reflected in the dynamic models but is good to understand from an operational perspective. The AVR testing can be done using lower resolution SCADA data (1-2 second resolution). This may not capture fast transients, overshoot, response time, and other characteristics. PMU or DFR data is generally required for validating these faster dynamics in the phasor domain and EMT models.

Can you share guidance on types of data for various commissioning tests for IBR plants?

The IESO asks for 1 sample per cycle data (e.g., PMU-type data) for dynamic tests, and some tests require this resolution of data. PMU-type monitoring data is required at the high-side of the main power transformers and recommended at the low side as well. The IESO also sees that it is relatively common for high-speed recording devices to be able to be configured to capture collector system measurements and also possibly IBR unit-level data, and this is now common practice in IESO footprint.

For evaluating AVR tests where a step change to the voltage reference is initiated, should the plant's response times be evaluated based on MVAR or voltage? Are there specific settling bands that the plant should maintain?

The IBR plant is not solely responsible for establishing voltage at the POI; rather, the PPC is commanding a MVAR set point value and this is used as the evaluation measurement to a change in reference signal. There are not universal requirements for settling time across all IBR plants and this may be evaluated on a case-by-case basis. This test can be helpful in uncovering site issues that affect operational performance.

Are there any recommendations you have for shaping contractual agreements with OEMs that ensure developers capability to execute rigorous testing during commissioning

The “gold standard” is to define precisely what you need as an IBR plant developer in terms of what you want tested, how to test it, and what the pass/fail criteria is. And then take that information to the OEM(s) and add that as a contractual obligation around commissioning. The key point here is to bring this to the OEM as early as possible. If these details show up later in the process (e.g., right before commissioning), it is very unlikely that they will get implemented. As an IBR developer/owner, you need to know exactly what the requirements/expectations need to be and communicate that early.

Key Themes

- **Commissioning as a Critical Reliability Stage Gate:** Commissioning is the last practical opportunity to confirm that an IBR plant will operate reliably once it enters service. Issues discovered after commercial operation are significantly more difficult and costly to correct. Treating commissioning as a formality rather than a reliability stage gate increases both operational and grid reliability risk.
- **Inconsistent Requirements Drive Uneven Commissioning Rigor:** Commissioning requirements and oversight vary widely across regions and transmission providers, leading to inconsistent testing practices and expectations. In some cases, minimal requirements result in insufficient verification and validation of IBR plant configuration, settings, capabilities, and operational performance. The absence of mandatory NERC requirements does not reduce the need for robust IBR plant commissioning as

comprehensive verification and validation efforts at commissioning set the IBR plant up for compliance once COD is attained.

- **Standard Tests Alone Do Not Capture Real-World Plant Behavior:** Common commissioning tests such as AVR, PFR, and curtailment are necessary but often insufficient to fully understand plant performance. Important operating conditions such as zero-power operation, communications system failures, and other failure scenarios are frequently under-tested. Expanding test scope to include realistic and challenging scenarios provides far greater confidence in plant behavior.
- **Models Must Be Actively Aligned with As-Commissioned Reality:** While EMT and phasor domain models are widely used during the interconnection study process, they often diverge from actual field implementation. This is partly attributed to a lack of model verification and validation around the time of commissioning. Models provide the most value when they are treated as living tools that inform commissioning and reflect the final “as-left” configuration, and should be maintained throughout the lifecycle of the facility.
- **End-to-End Integration Is Essential for Successful Commissioning:** Reliable IBR operation depends on the coordinated performance of controls, SCADA, communications networks, telemetry, and supporting infrastructure. Commissioning must therefore be approached as an end-to-end process, beginning early in the project lifecycle and continuing through handoff to operations. Early preparation, clear requirements, comprehensive contractual agreements, disciplined testing, and proactive change management consistently reduce risk, delays, and rework.