



ERCOT AGS-ESR Adoption and Proposed Requirements

Yunzhi Cheng
ERCOT Operations Support

ESIG Benefits of GFM BESS Taskforce Meeting
Nov. 7, 2024

ERCOT Team Support

Operations: Fred Huang, Yunzhi Cheng, Amro Quedan, Ali Yazdanpanah, Hamzeh Davarikia
Planning: Sun Wook Kang, John Schmall, Jonathan Rose, Scott Zuloaga

The ERCOT Region

The interconnected electrical system serving most of Texas, with limited external connections

- 90% of Texas electric load; 75% of Texas land
- 85,508 MW peak, August 10, 2023
- More than 54,100 miles of transmission lines
- 1250+ generation units (including PUNs)

ERCOT connections to other grids are limited to ~1,220 MW of direct current (DC) tie capacity

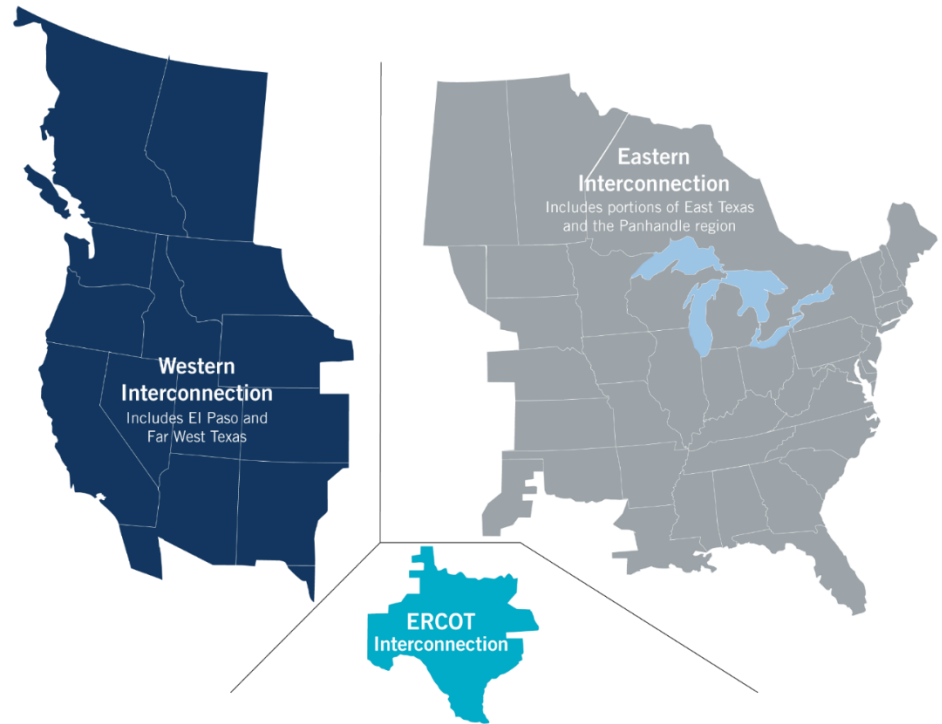

ERCOT Quick Facts

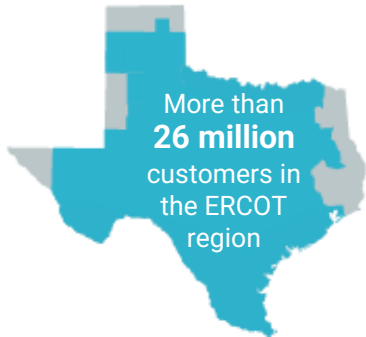

90% of Texas Load

75% of load is competitive choice customers

1 MW of electricity can power about 200 Texas homes during periods of peak demand

1,250+

generating units, including PUNs

54,100+

miles of high-voltage transmission

103,609+ MW

of expected capacity for summer 2024 peak demand

\$3,3 billion

transmission projects endorsed in 2022

1,873+

active market participants that generate, move, buy, sell or use wholesale electricity

85,508 MW

Record peak demand (August 10, 2023, 5-6 pm)

39,450 MW

of installed wind capacity

27,881 MW

Wind generation record (June 17, 2024)

69.15%

Wind penetration record (April 10, 2022, 1 am)

85,116 MW

Weekend peak demand record (August 20, 2023, 4-5 pm)

25,333 MW

of installed solar capacity

21,667 MW

Solar generation record (Sep. 8, 2024)

42.98%

Solar penetration record (March 28, 2024)

2023 Generating Capacity

Reflects operational installed capacity based on November 2022 CDR report for Summer 2023.

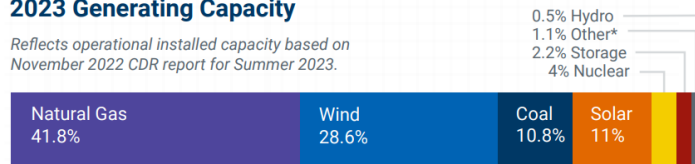

The sum of the percentages may not equal 100% due to rounding.

*Other includes biomass and DC Tie capacity.

2022 Energy Use

*Other includes solar, hydro, petroleum coke (pet coke), biomass, landfill gas, distillate fuel oil, net DC-tie and Block Load Transfer important/exports and an adjustment for wholesale storage load.



ERCOT Wind Additions by Year (as of June 30, 2024)

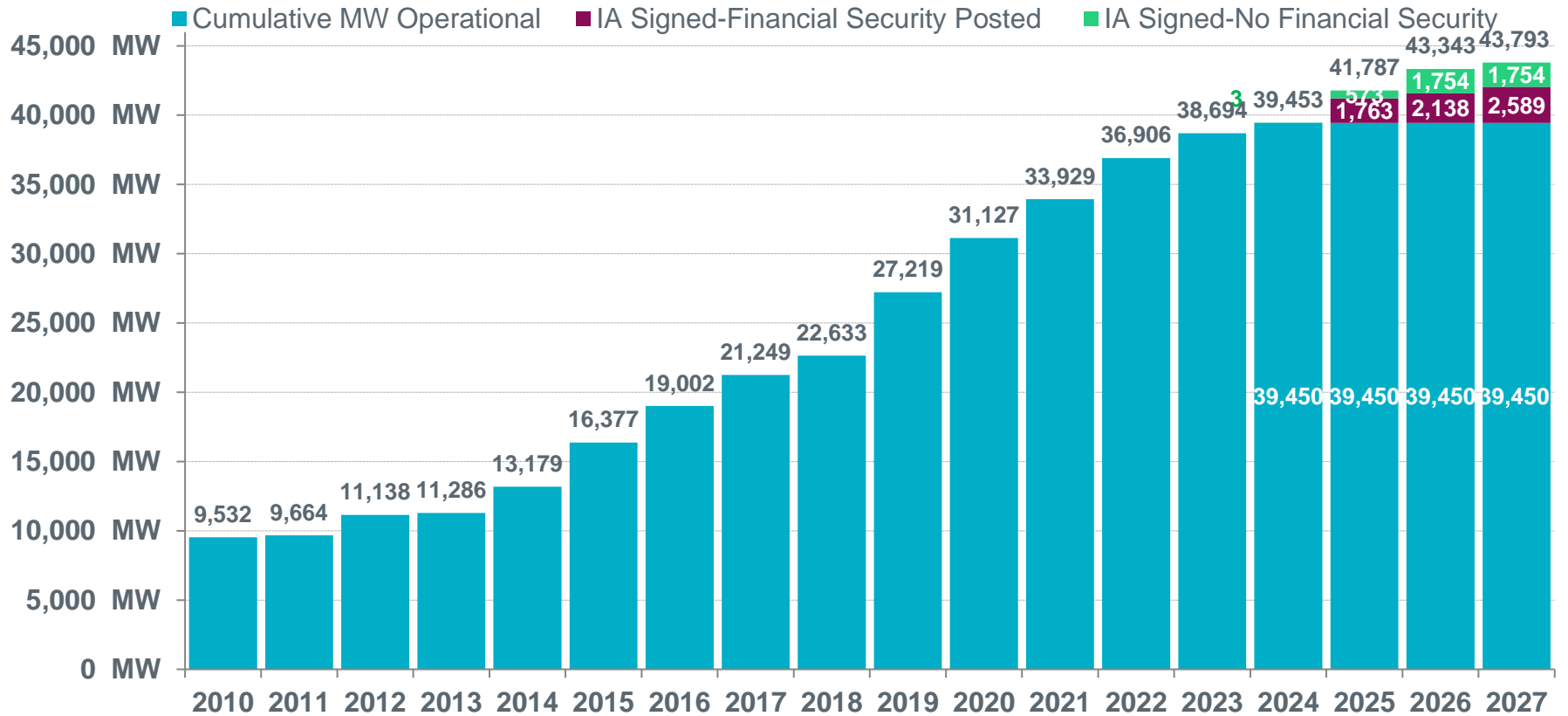

ERCOT Solar Additions by Year (as of June 30, 2024)

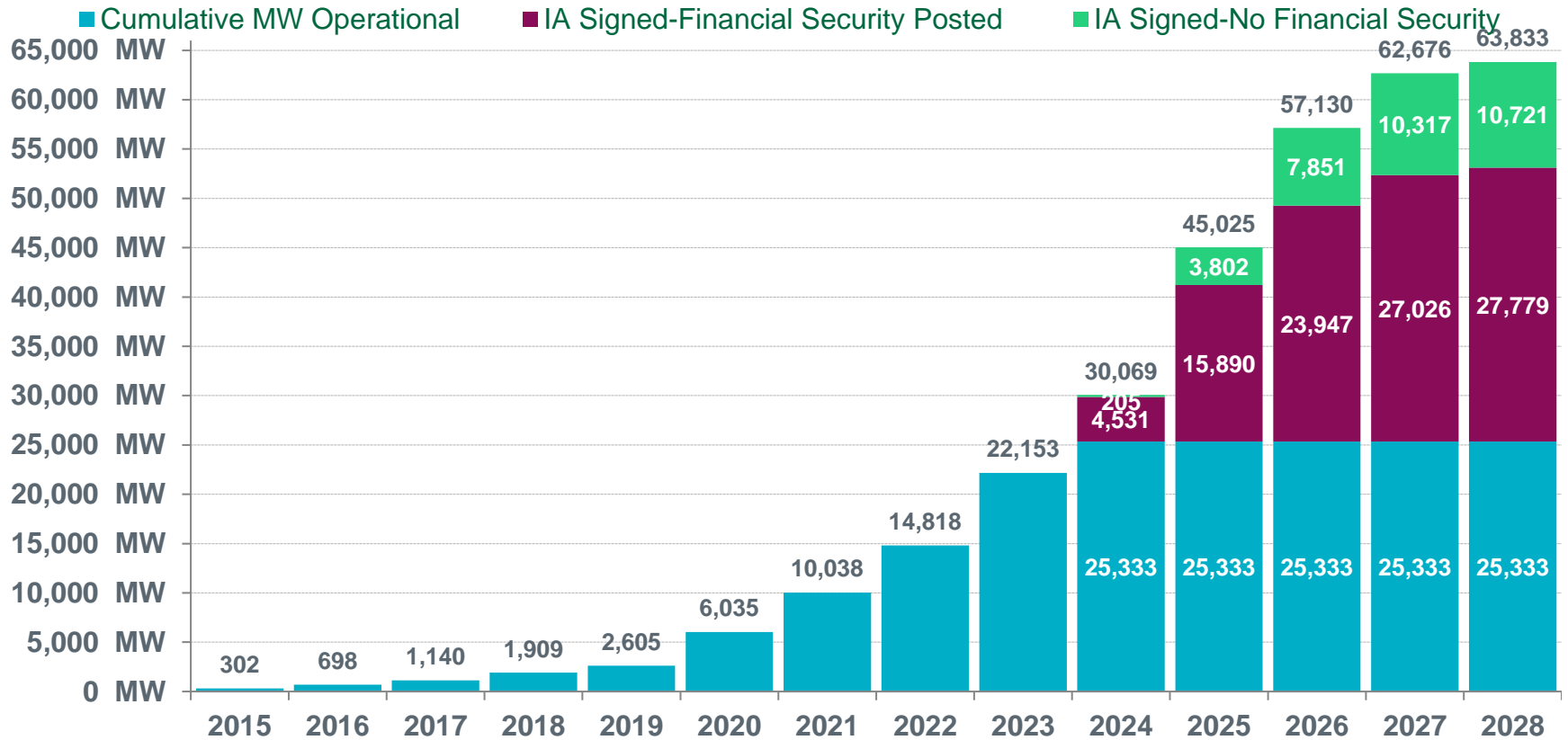

ERCOT Battery Additions by Year (as of June 30, 2024)

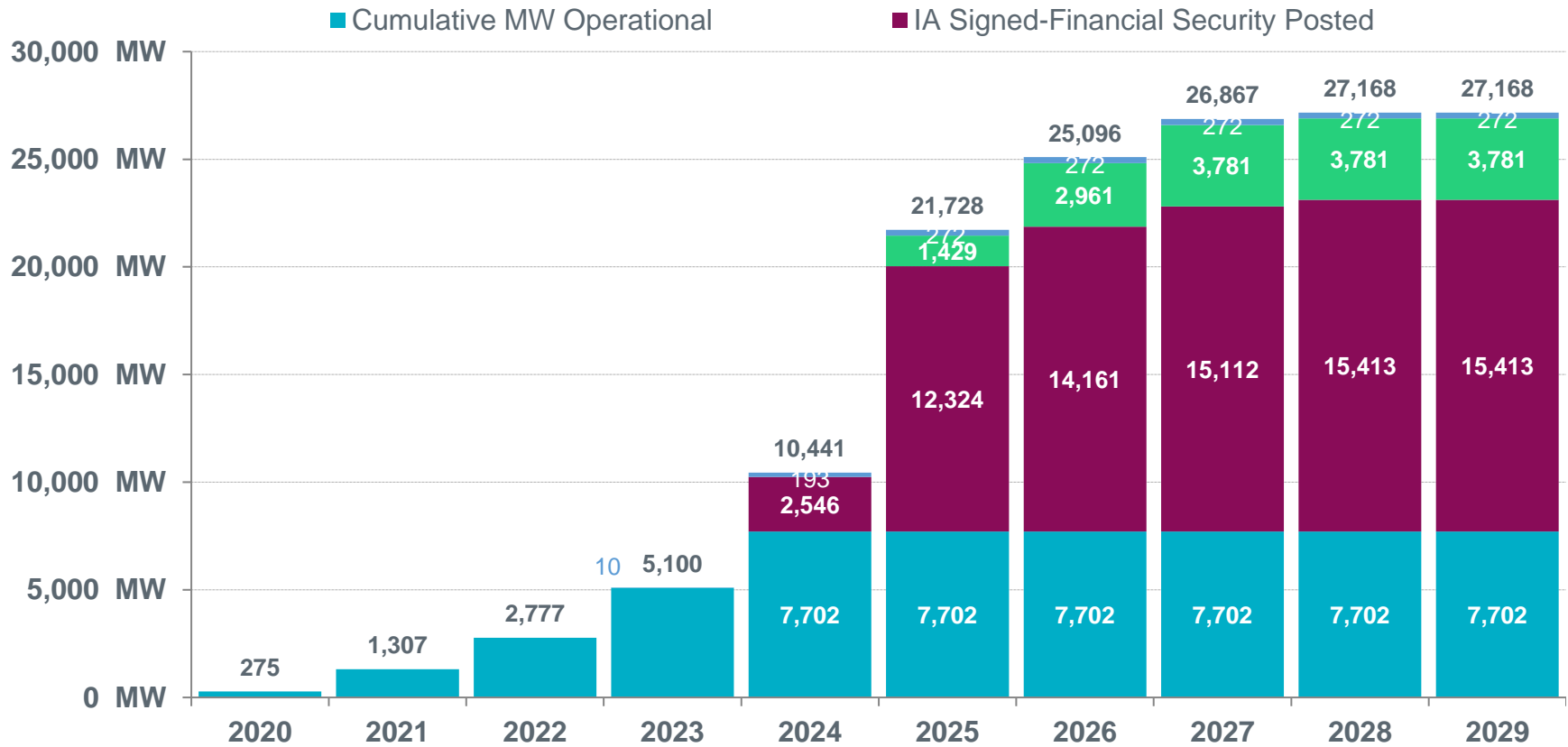

ERCOT IBR Growth

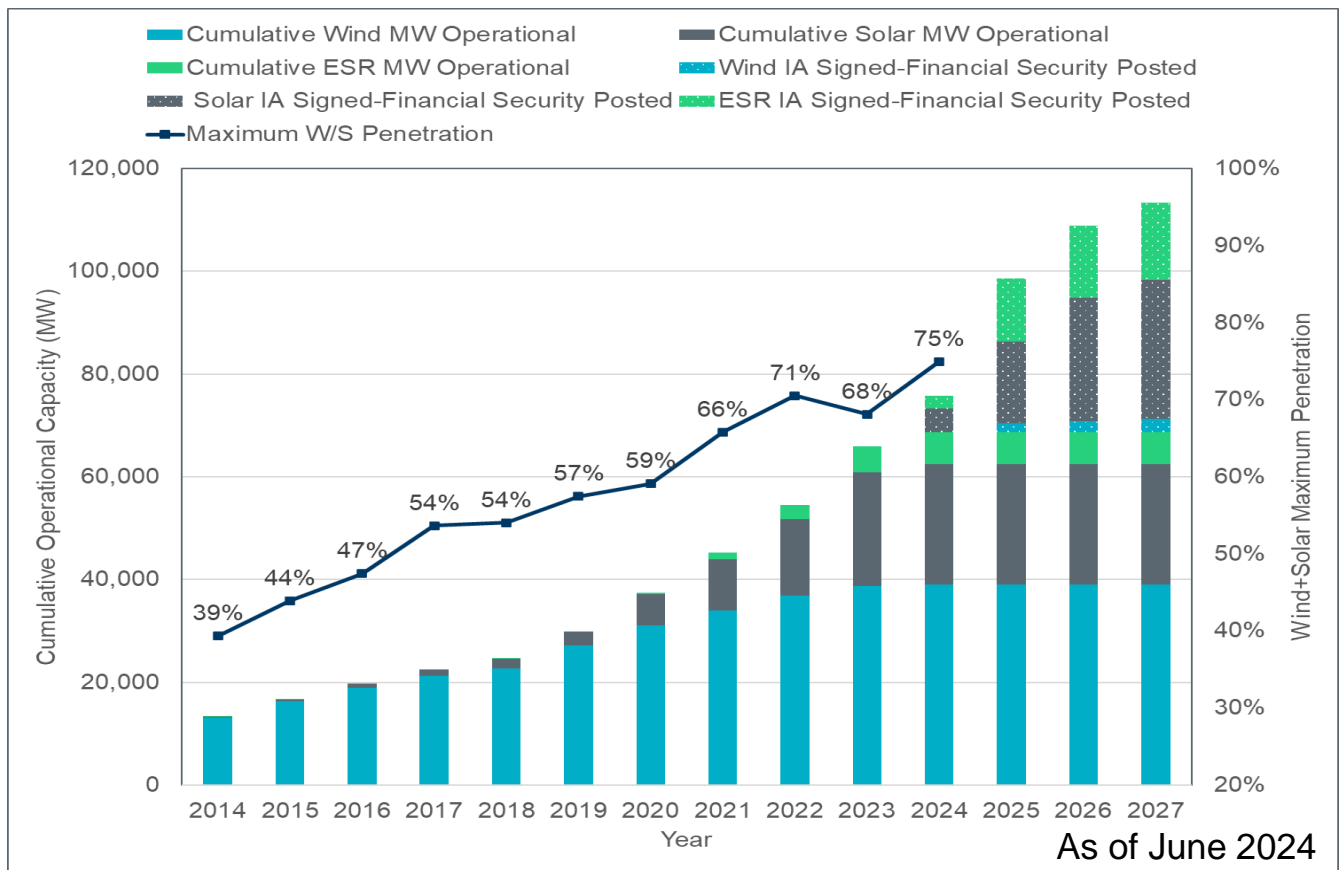

ERCOT could exceed 100 GW IBRs connection by 2025. Further growth is also projected based on the current ERCOT resource capacity trend.

<https://www.ercot.com/gridinfo/resource>

Advanced Grid Support Inverter-Based Energy Storage Resources (AGS-ESR)

- As IBRs become increasingly prevalent in ERCOT grid, the absence of online conventional synchronous generation resource support underscores the necessity for efforts to ensure stable grid operation
- Efforts to maintain grid reliability under increasing IBR penetration include:
 - [Synchronous condensers project](#) endorsed in Dec 2023
 - [PGRR109](#) model review process effective in May 2024
 - [NOGRR245](#) enhancing operating requirements approved in Oct 2024
- With minimum impact to the hardware, AGS-ESR can enhance grid stability, reduce generation curtailment due to stability constraints, reduce the severity of grid disturbance

Preliminary Assessment of AGS-ESR impact

- ERCOT preliminary AGS-ESR assessment
 - Scenario 1: a weak grid condition (a simple test case in PSSE to prove the concept)
 - Scenario 2: West Texas grid (PSSE)
 - Scenario 3: An actual ERCOT local area with identified stability constraints (PSSE and PSCAD)
 - Scenario 4: Grid Stability and GTC (Generic Transmission Constraint) assessment (TSAT)
- AGS-ESR dynamic models used in these tests were supported by Pacific Northwest National Laboratory (PNNL) and Electric Power Research Institute (EPRI)
- Acknowledgment:
 - Dr. Wei Du from PNNL for providing AGS-ESR PSSE (REGFM_A1) and PSCAD models
 - Dr. Deepak Ramasubramanian from EPRI for providing AGS-ESR PSSE and PSCAD models
 - Powertech for providing AGS-ESR TSAT model (REGFM_A1)

Scenario 1: Weak Grid Test Case Simulation (PSSE)

- A simple test case was developed to mimic known stability challenges in ERCOT

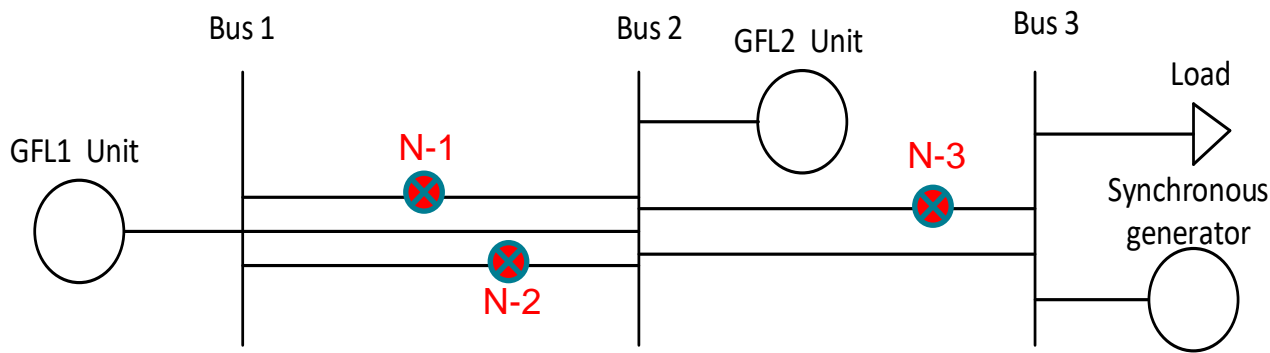

Unit	MVA
GFL1	300
GFL2	200
Syn Gen	488
Load	800

Bus 1 Voltage Plot

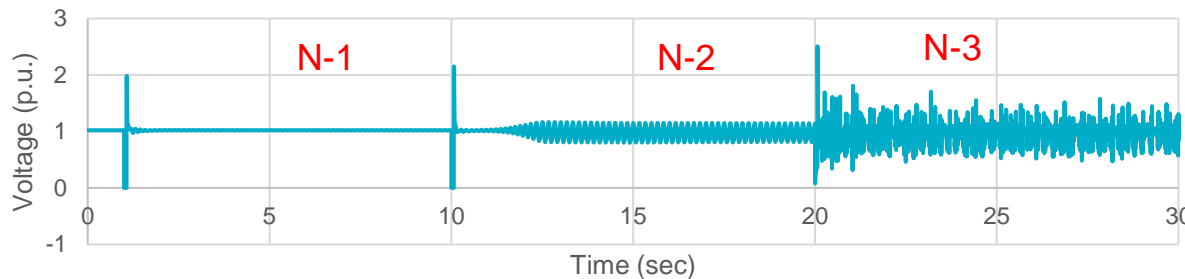

Grid Following (GFL) IBRs instability identified in a weak grid condition

Note: The test cases are available at: <https://sites.google.com/view/weakgrid/home>

Scenario 1: Weak Grid Test Case Simulation (PSSE)

- Two AGS-ESRs were added next to GFL1 and GFL2

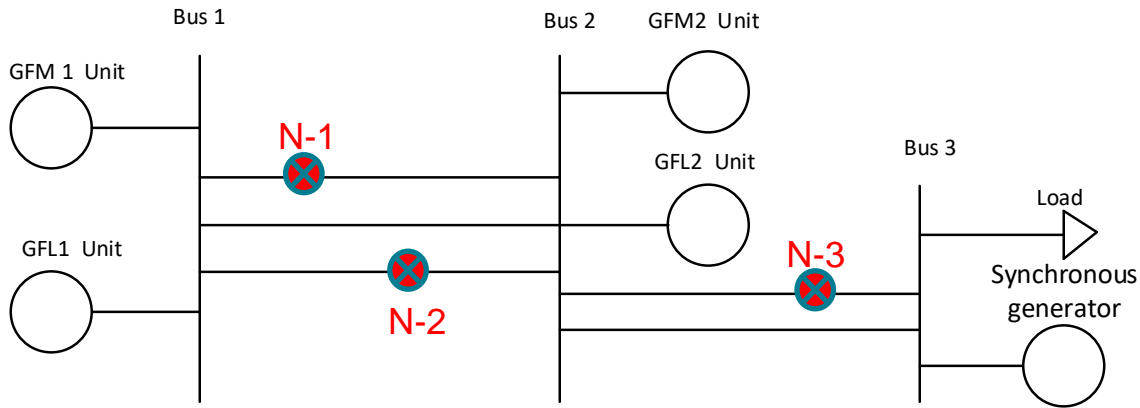

Unit	MVA
GFL1	300
GFL 2	200
Syn Gen	488
Load	800
GFM 1 (AGS-ESR1)	70
GFM 2 (AGS-ESR2)	70

Bus 1 Voltage Plot

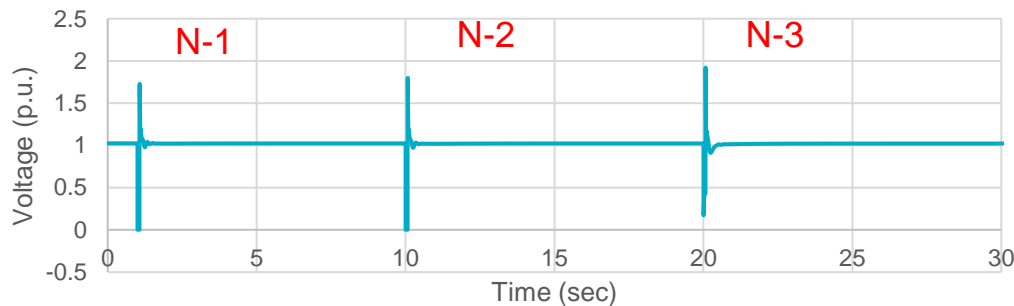

The addition of AGS-ESRs improves the overall system stability performance under weak grid conditions

Scenario 2: West Texas Grid (PSSE)

- More than 35 GW IBRs (including ~2GW ESRs) are connected to West Texas transmission grid
- Six synchronous condensers are proposed to strengthen the West Texas grid to provide system security and resilience
- This scenario is to assess the impact if ~2GW ESRs are AGS
 - Generic AGS-ESR models were used to evaluate the impact in this assessment
 - The ESR inverters maximum current capability were kept the same as the existing models
- Both AGS-ESR models provided by PNNL and EPRI were tested and similar results were obtained

WTX System Strength with AGS-ESR (PSSE)

- The presence of the AGS-ESRs did not reduce the dispatch stability limit
- AGS-ESRs improved the system numerical performance
- Notable Observations:
 - Reduce both voltage dip and overshoot
 - Reduce affected IBRs in WTX, less active power temporary reduction and swing
 - Reduce angle jump

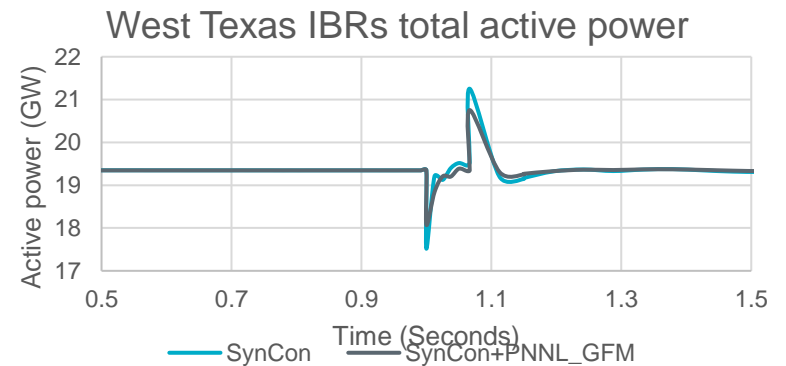
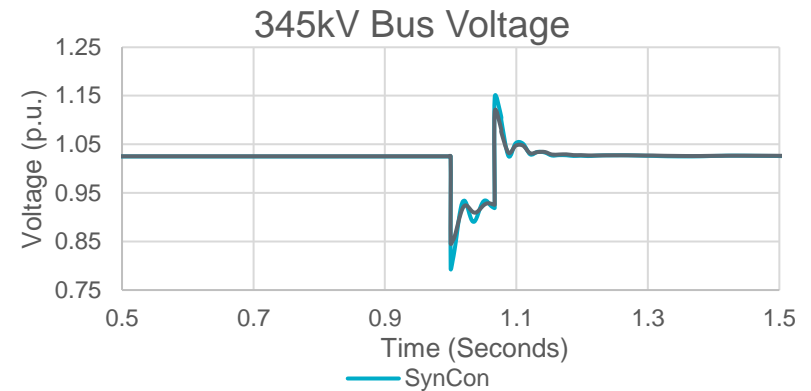

Scenario 3: Local area with identified instability (PSSE and PSCAD)

- A local area (138kV) in the ERCOT grid has been identified with stability issue due to weak grid challenges
 - Generation resources in this area include wind, solar, and ESR (all are GFL inverters)
 - Stability study indicated stability constraints under N-1 and N-1-1 based on original models provided by the developers and resource entities.
- A AGS-ESR model was used to replace the original GFL model for the ESR. The results in both PSSE and PSCAD tests show stable response for both N-1 and N-1-1 and no stability constraint is needed if the ESR is equipped with proper AGS capability

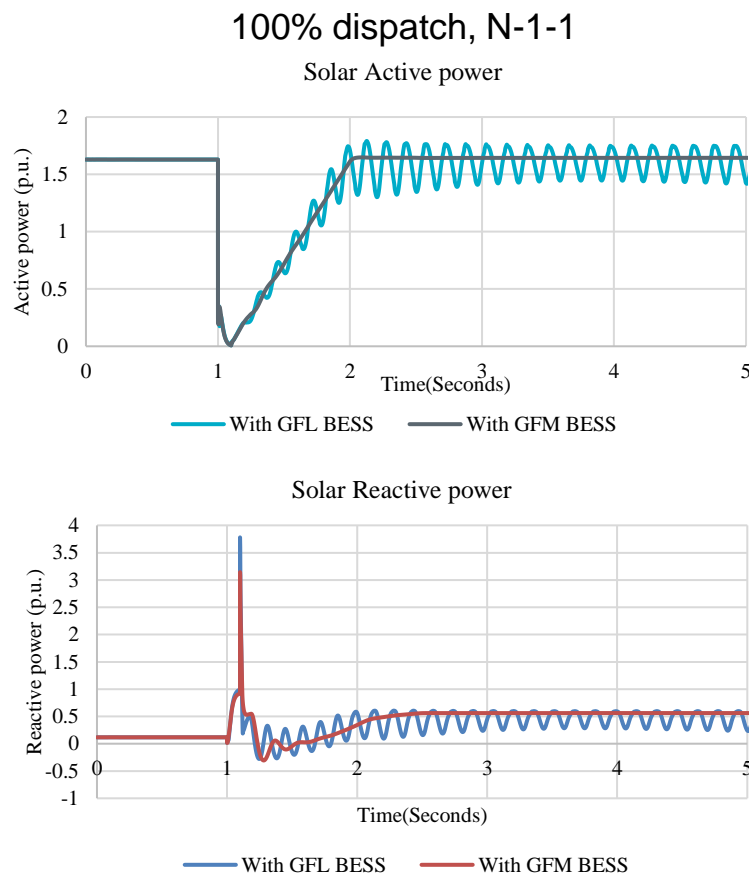

Scenario 3: Local area with identified instability (PSSE and PSCAD)

- PSCAD simulation results for 100% dispatch under N-1-1

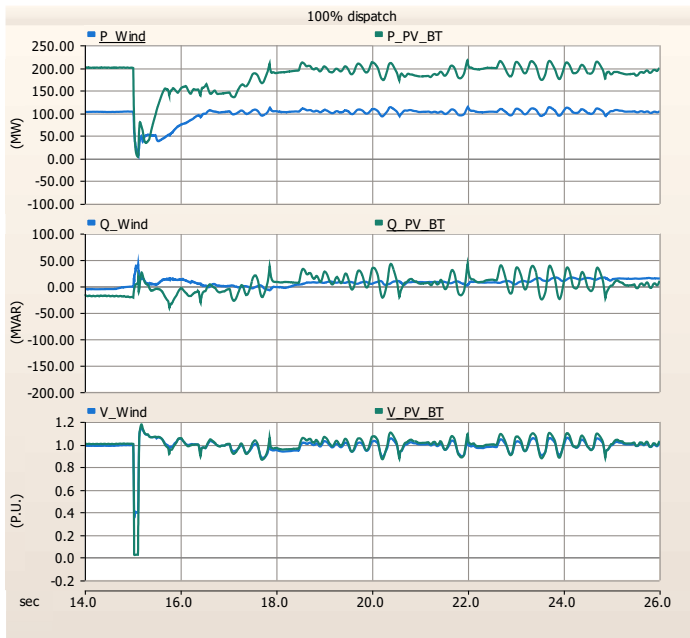

ESR modeled as GFL (original model)

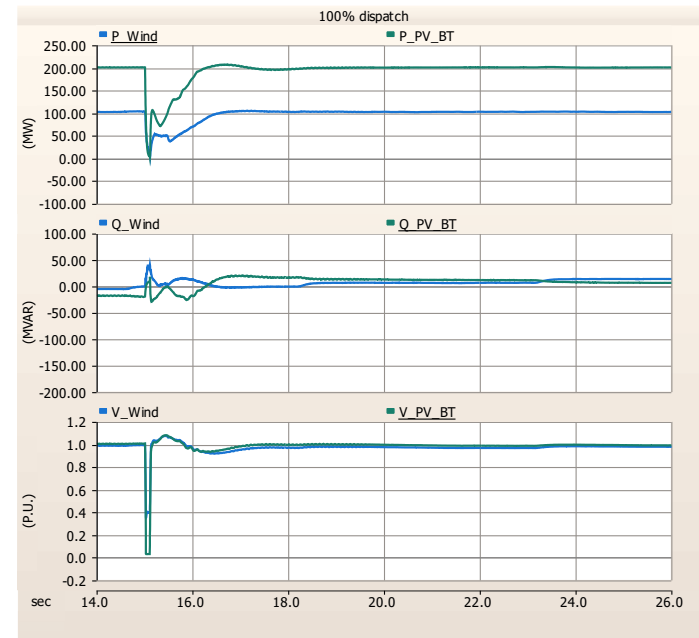

ESR modeled as AGS (EPRI VSM model)

Scenario 4: Grid Stability and GTC Assessment (TSAT)

- Study assumptions and method
 - Each operational ESR modeled as AGS (REGFM_A1) with default parameters provided by PNNL
 - The ESR inverters maximum current capability kept the same as the existing models
 - Studied using off-line TSAT assessment
- With AGS-ESRs, several major ERCOT GTC (Generic Transmission Constraint) limits can be increased by 5-10% based on operational test cases (without future transmission upgrade and resources). For several other GTCs, the constraint could be mitigated with AGS-ESRs.

AGS-IBR requirement and test framework

- ERCOT contracted Electranix to help recommend the required IBR advanced grid support capability and test framework
- ERCOT also reached out to major IBR OEMs to understand the existing and potential advanced grid support capability (like GFM)
 - OEMs for inverter-based ESRs, including Tesla, SMA, Sungrow, and Power Electronics, shared their GFM BESS models to support this project
 - OEMs for wind and solar currently **don't** have commercially available product
- ERCOT proposed NOGRR 277 and PGRR 121 for AGS-ESR requirements on 10/31/2024

Test Requirements of AGS-ESR*

- ERCOT recommended two types of model tests for assessing AGS-ESR performance
 - Site-specific model quality tests (MQT)

Test #	Test Name	Testbench System	Applicable Software Platform
1	Flat start	TB1	PSCAD, PSS/E, TSAT
2	Phase angle jump	TB1	PSCAD
3	Small voltage disturbance	TB1	PSCAD, PSS/E, TSAT
4	Frequency change and inertia response	TB1	PSCAD, PSS/E, TSAT
5	System strength	TB1	PSCAD, PSS/E, TSAT
6	Large voltage disturbance	TB1	PSCAD, PSS/E, TSAT
7	Loss of synchronous machine	TB2	PSCAD, PSS/E, TSAT

- ERCOT will release PSS/E and PSCAD MQT tools (optional) for AGS-ESR MQT

* ERCOT AGS ESR Requirements, available at:
<https://www.ercot.com/files/docs/2024/10/09/ERCOT%20AGS-ESR%20Oct-11-2024%20IBRWG.pdf>

Test Requirements of AGS-ESR

- ❑ ERCOT recommended two types of model tests for assessing AGS-ESR performance
 - Unit model validation test (i.e., technology specific model test)
 - 1) Voltage Angle Step Test
 - 2) Step Change in Voltage
 - 3) System Strength Test
 - 4) Voltage Ride Through
 - 5) SubSynchronous Test

Testbenches for AGS-ESR

□ Testbench 1 (TB1):

- Ideal voltage source with controllable voltage (including magnitude, phase, and frequency),
- Variable series impedance (Z_{th}) to adjust the short circuit ratio (SCR) of the connection point.

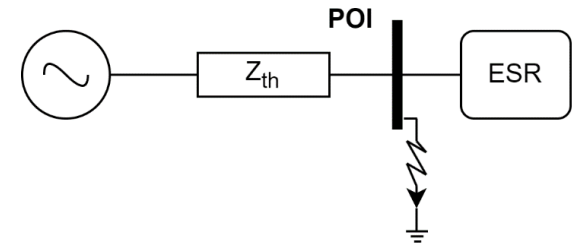

□ Testbench 2 (TB2):

- A voltage source with a circuit breaker to be able to disconnect the source from the system.
- A constant impedance load with power factor of 0.95
- The ESR model under test (project ESR)
- A duplicate of the ESR model with the same size as the project ESR.

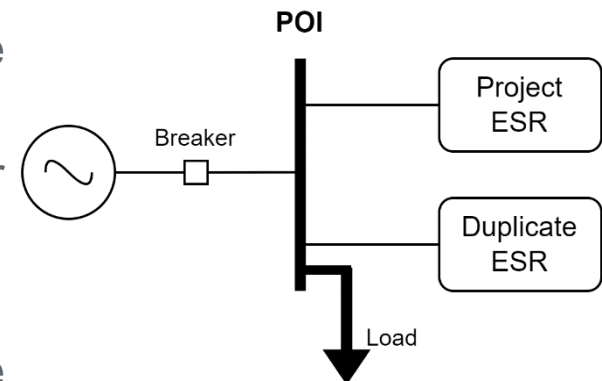

Test 1 - Flat Start Test

❑ Purpose of Test:

- Proper initialization of the model, verifying the steady state response, and ensuring the numerical stability of the simulation.

❑ Setup:

- Using Testbench 1, SCR at connection point is set to 3 with X/R of 6
- Initial dispatch of ESR is set to the max discharging for active power with approximately zero reactive power

❑ Test Sequence:

- No disturbance
- Simulate for a minimum of 20 seconds

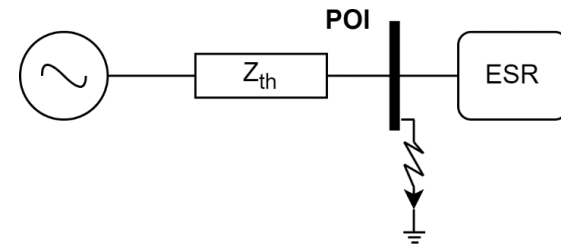

Flat Start Test

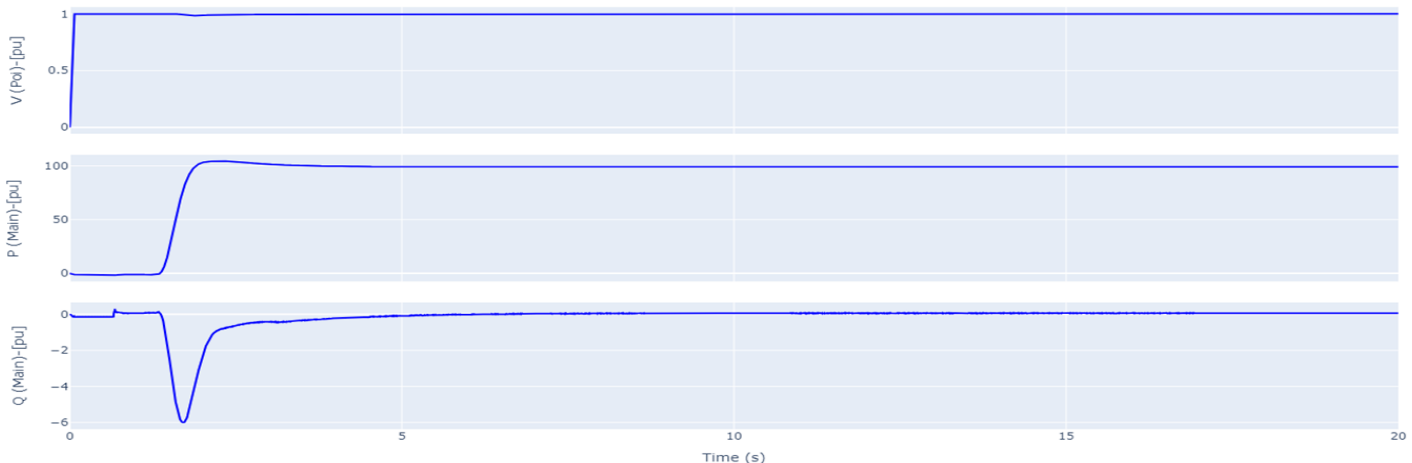

Acceptable Results

Test 2 - Phase Angle Jump Test

❑ Purpose of Test

- Capability to maintain the voltage phasor and resist to angle change,
- Stable behavior when it is working close to the maximum current limit

❑ Setup:

- Using Testbench 1, SCR at connection point is set to 3 with X/R of 6
- Initial dispatch of ESR is set to the max discharging for active power with approximately zero reactive power

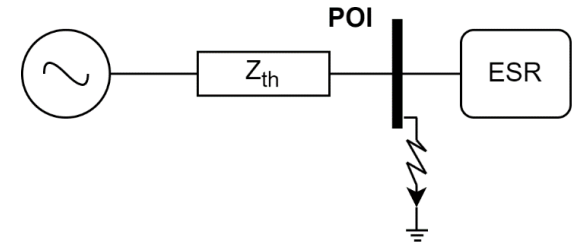

❑ Test Sequence:

- Step changes to the phase angle of the 3-phase voltage source as follows:

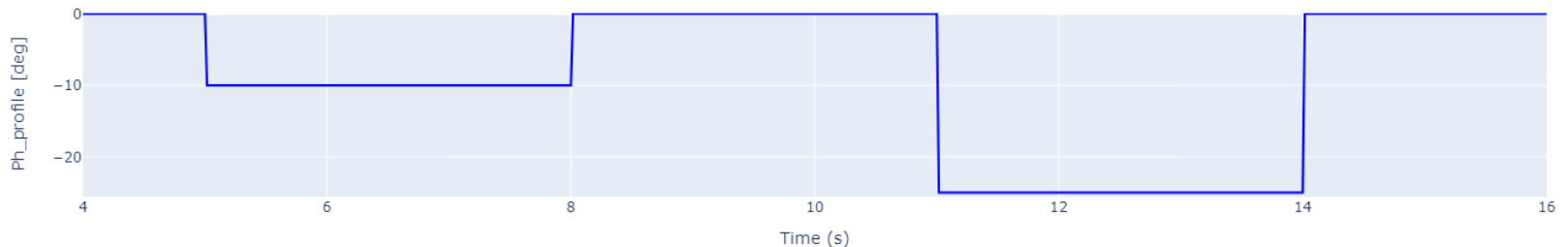

Test 2 - Phase Angle Jump Test

Success Criteria

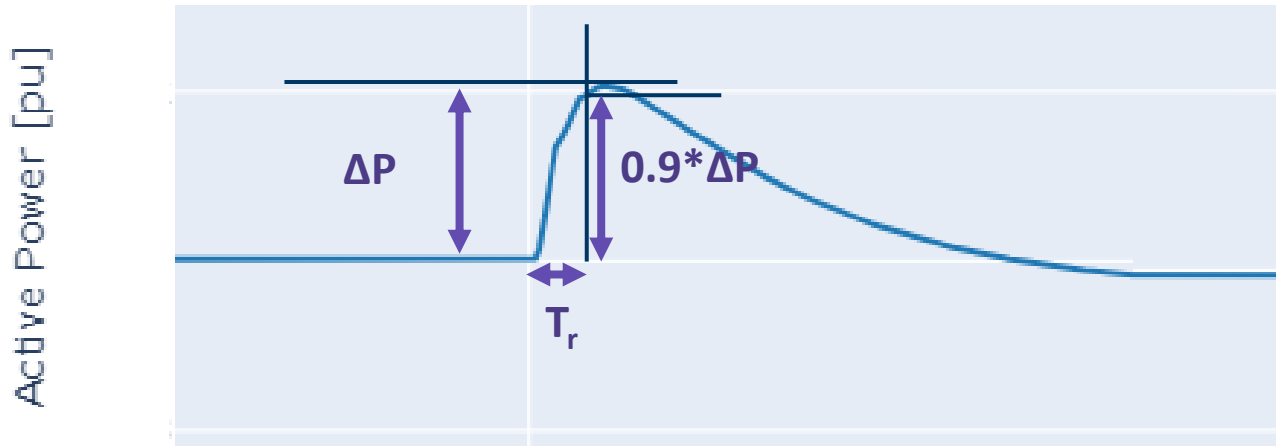

Summary:

For 10-degree angle jump
→ $T_r \leq 1$ Cycle

ΔP : Initial change

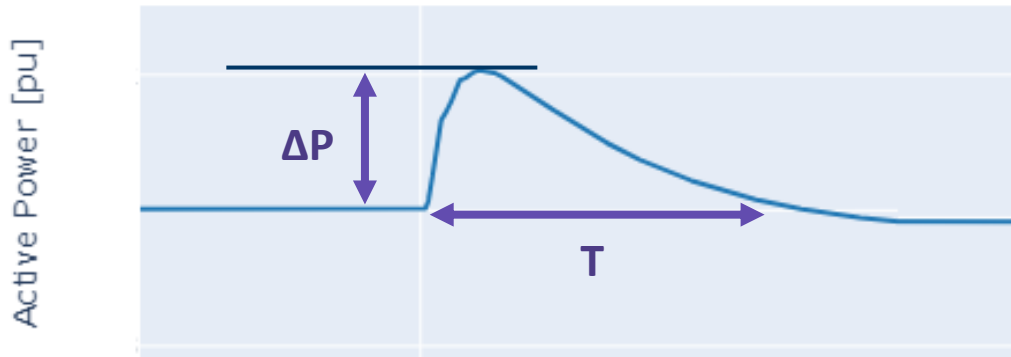

Summary:

For 10-degree angle jump → $\Delta P \geq 0.2$ pu

For 25-degree angle jump → $\Delta P \geq 0.5$ pu

$T \geq 3$ Cycles

Test 3 - Small Voltage Disturbance Test

❑ Purpose of Test

- Capability to resist change in voltage magnitude
- Reactive power response under small voltage step change

❑ Setup

- Using Testbench 1, SCR at connection point is set to inf ($Z_{th} = 0$)
- Initial dispatch of ESR is set to the max discharging for active power with approximately zero reactive power

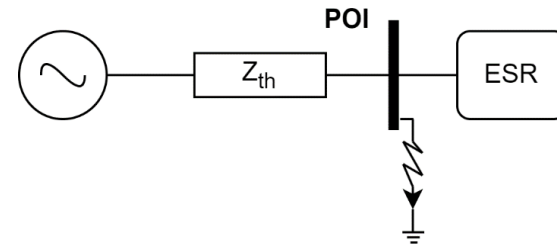

❑ Test Sequence

- +/- 3% instantaneous change of voltage magnitude of the source

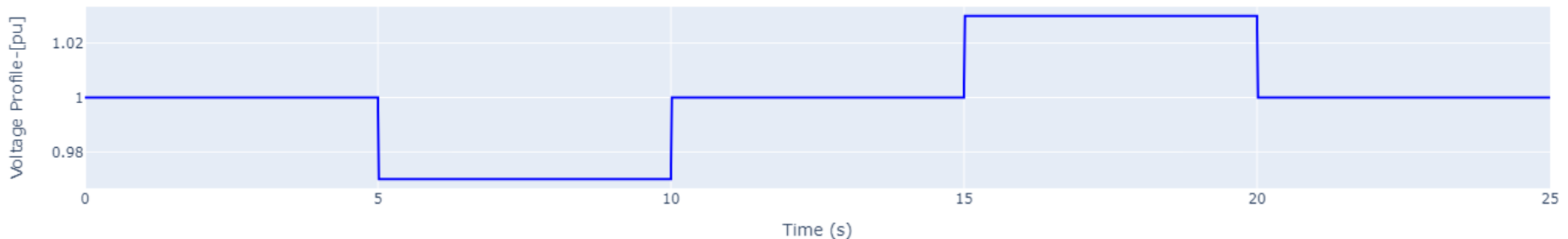

Test 3 - Small Voltage Disturbance Test

Success Criteria

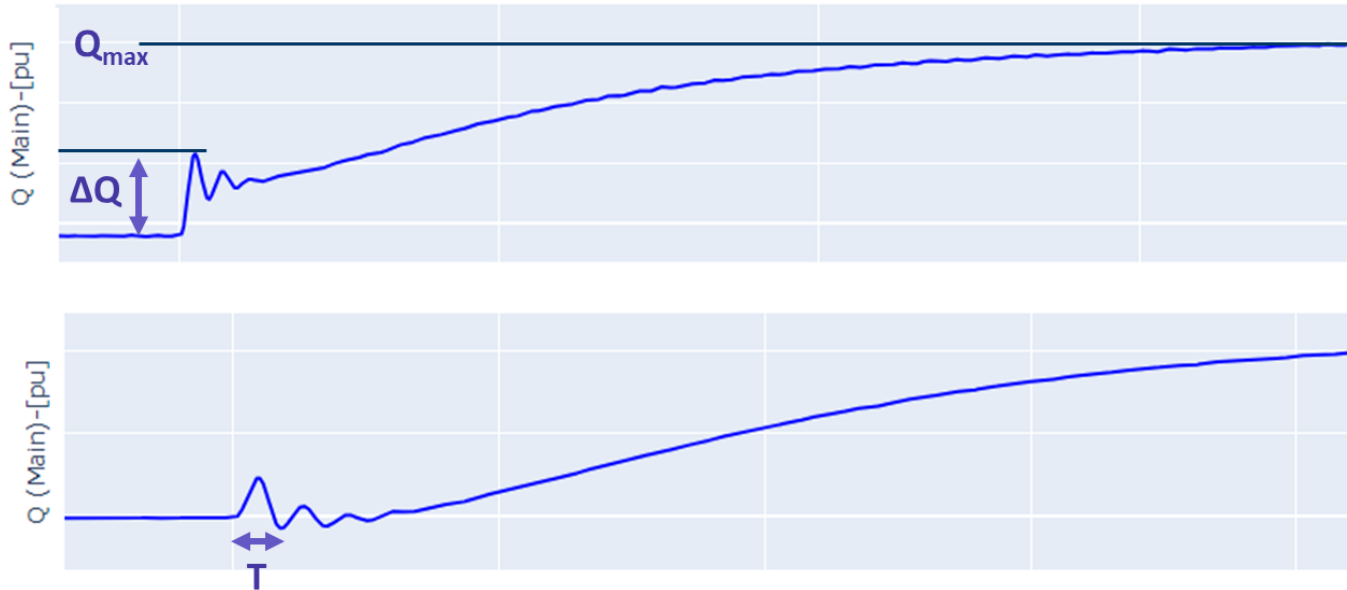

Summary:

$\Delta Q \geq 0.03$ pu

$T \geq 6$ Cycles

$Tr \leq 1$ Cycle

Tr : the time Q reaches to $0.9 * \Delta Q$

Reactive power reaches to Q_{max}

Test 4 - Frequency Change and Inertia Response Test

❑ Purpose of Test

- Active-power frequency response capability of the ESR
- Estimate inertia response

❑ Setup

- Using Testbench 1, SCR at connection point is set to 3. System Equivalent X/R is set to 6.
- Initial dispatch of ESR is set to zero for active power with approximately zero reactive power

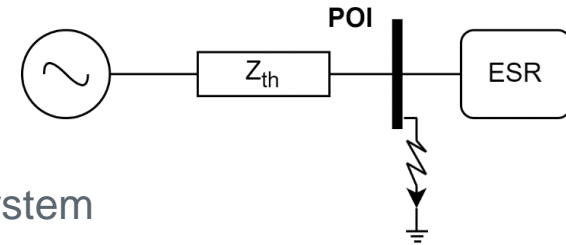

❑ Test Sequence

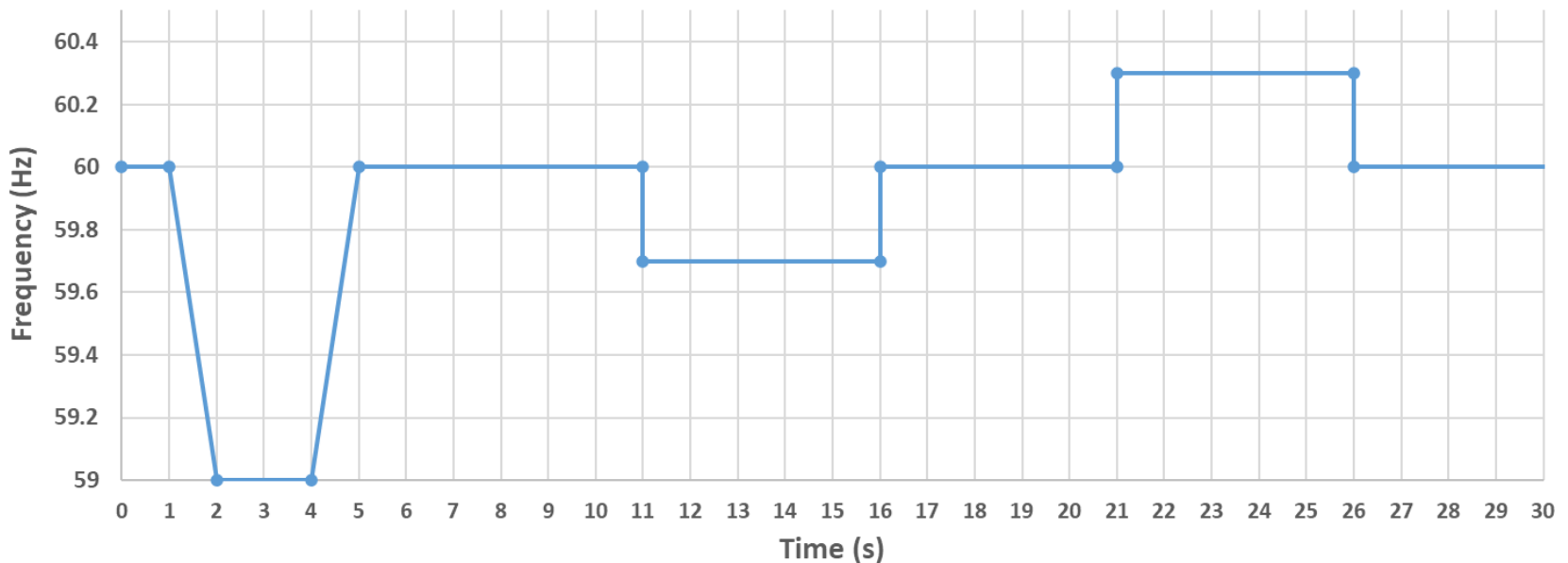

Test 4 - Frequency Change and Inertia Response Test

Success Criteria

- Plant real and reactive power output should be well controlled. System frequency and voltage should not oscillate excessively or deviate from steady state levels for any significant amount of time.
- Voltage settles to a stable operating point when frequency is not ramping.
- The equivalent inertia constant, calculated as below, should be greater than 2.5 s.

$H \approx 60 * \Delta E$ [s], where: ΔE is the area under the per unit active power production of the ESR from 0 to 0.5s, when the RoCoF is 1 Hz/s.

- Active power should settle according to its frequency droop and deadband settings when frequency is not ramping.

Note: According to ERCOT Nodal Operating Guide Section 2.2.7 Turbine Speed Governors, the droop setting of ESR shall not exceed 5%.

- Any oscillation shall be damped

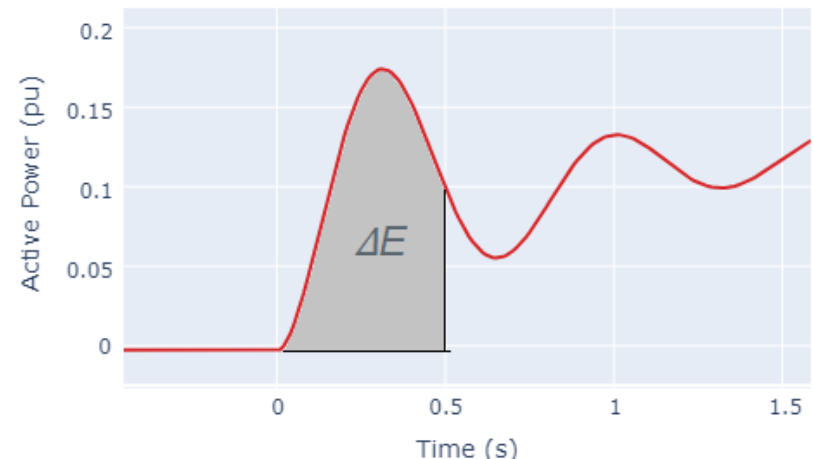

Test 5 - System Strength Test

❑ Purpose of Test

- AGS-ESRs shall demonstrate stable response for all tested SCR values from 10 to 1.2

❑ Setup

- Using Testbench 1, initial SCR at connection point is set to 10. System Equivalent X/R is set to 6
- Initial dispatch of ESR is set to the max discharging for active power with approximately zero reactive power

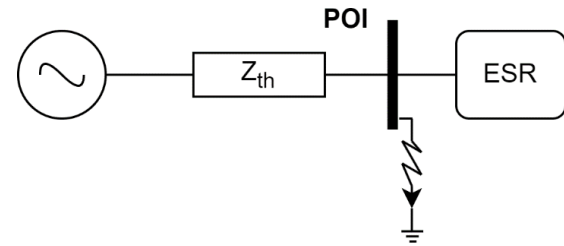

❑ Test Sequence

- SCR at connection point stepped down repeatedly in this progression: 10, 5, 3, 1.5, 1.2
- A 3-phase, bolted, 4-cycle fault is applied just before each SCR transition. The SCR transition occurs at fault clearing time

Test 5 - System Strength Test

Success Criteria

- Plant real and reactive power output and RMS voltage should be well controlled, and plant shall not trip nor reduce power or voltage for any extended period of time for all tested SCR range from 10 to 1.2, except during the fault
- Example of Acceptable Results

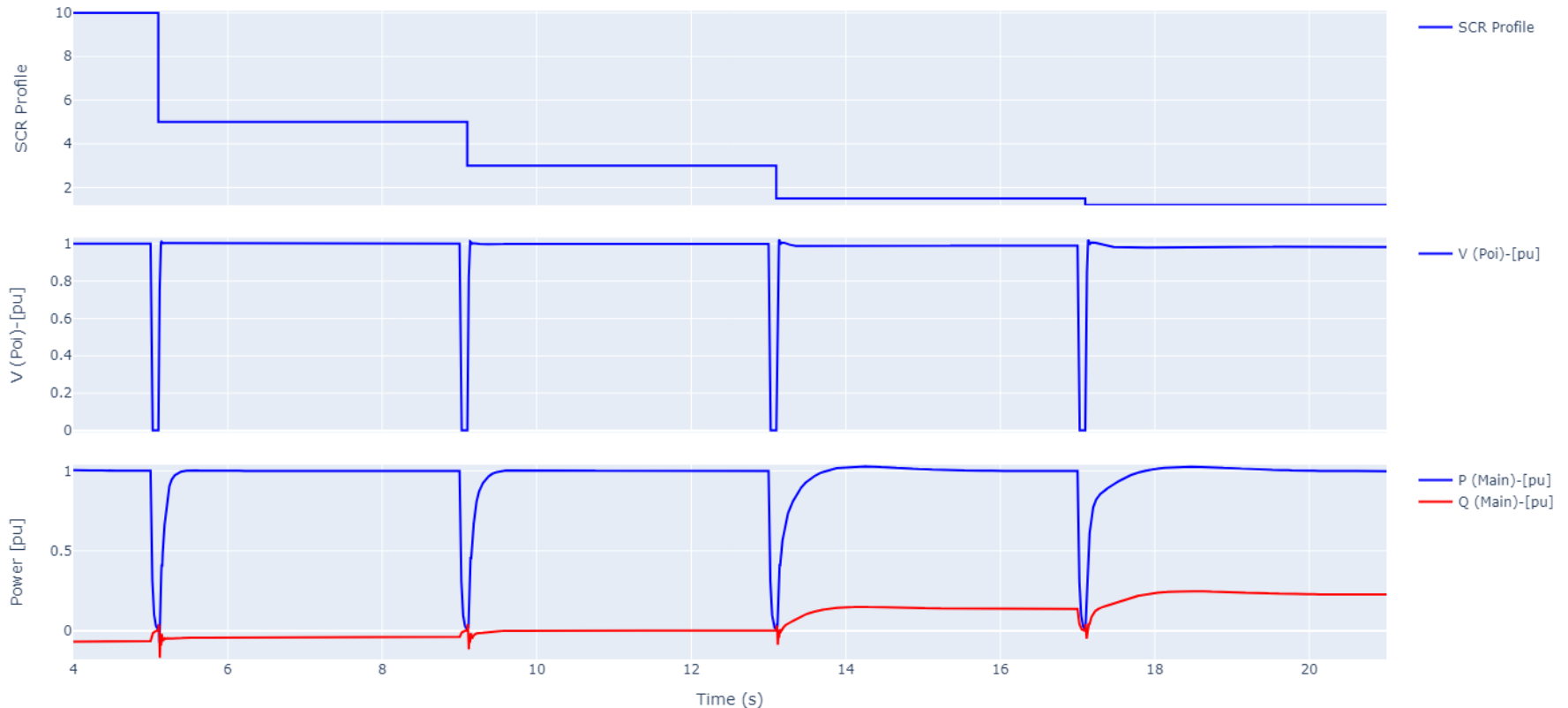

Test 6 - Large Voltage Disturbance Test

- ❑ Large voltage disturbance test for AGS_ESR are the same as existing IBRs.
 - Low voltage ride-through (LVRT)
 - High voltage ride-through (HVRT)
- ❑ Details are described in the [DWG Procedure Manual](#)

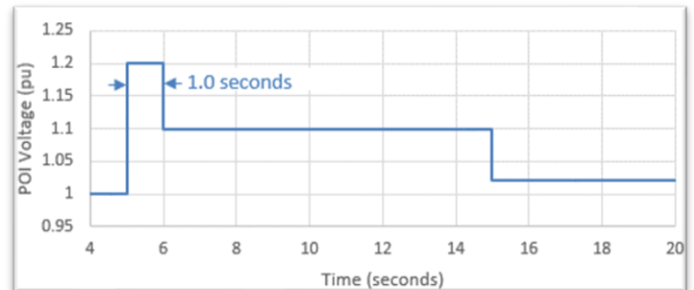
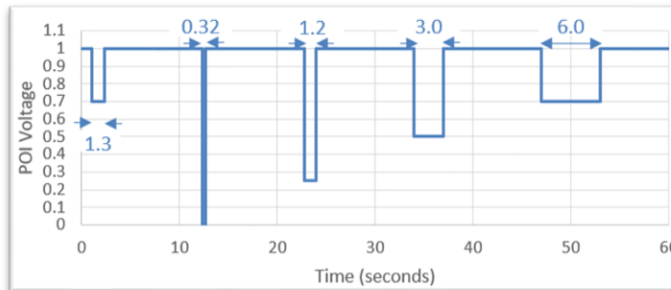
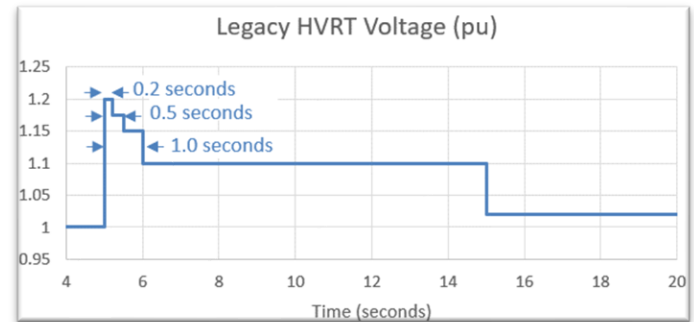
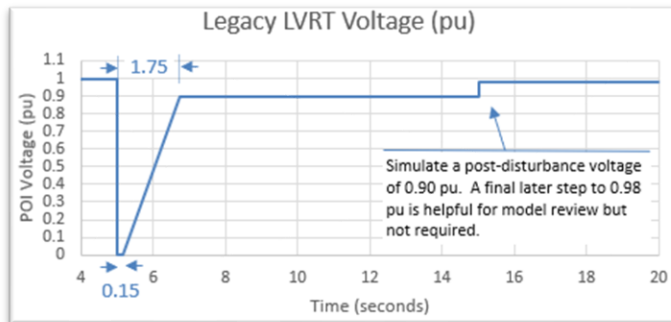

Test 7 - Loss of Synchronous Machine Test

❑ Purpose of Test

- Ability to form voltage and work in parallel with another AGS-ESR
- It is not intended to examine the black start capability of AGS-ESR nor to require AGS-ESRs operate on a grid without synchronous resources

❑ Setup

- Use Testbench 2. Dispatches (pu based on project plant rating) are as follows:
- Scenario 1: P1 = 0.3 pu discharging, P2 = 0.1 pu discharging, and L = 1.3 pu
- Scenario 2: P1 = 0.6 pu charging, P2 = 0.4 pu charging, and L = 0.7 pu
- Scenario 3: P1 = 0, P2 = 1 pu discharging, and L = 1.65 pu

❑ Test Sequence

- Simulate the system until a stable response is achieved for the given scenario, ensuring there are no oscillations.
- Disconnect the voltage source (no fault) and continue simulation for at least 10 seconds.

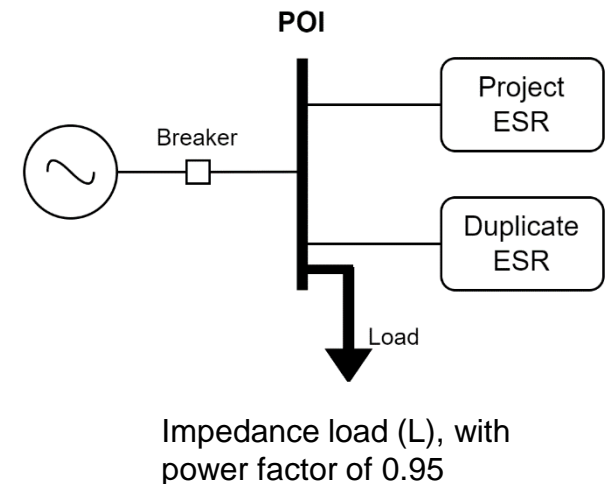

Test 7 - Loss of Synchronous Machine Test

Success Criteria

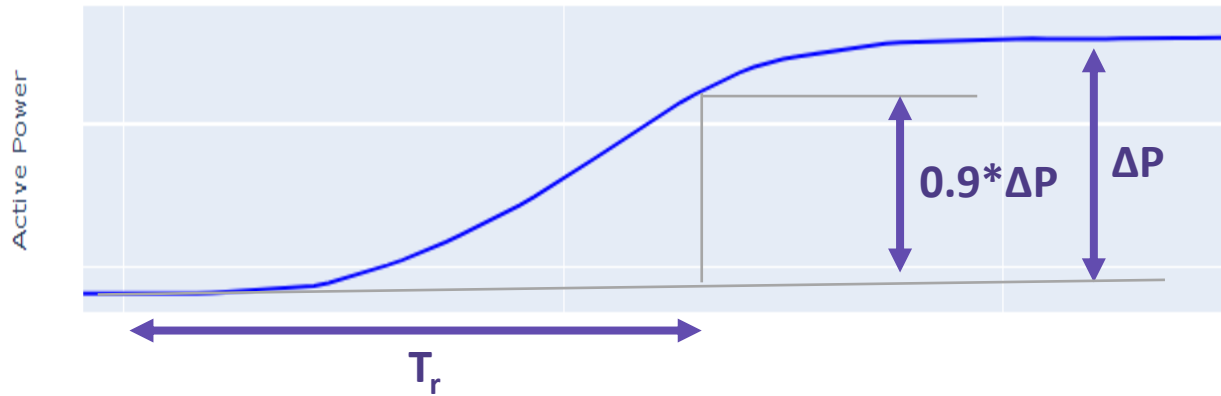

Summary:

- Settling time $< 5s$
- Oscillation damped less than 10 s
- $T_r \leq 1$ Cycle

Questions?



Appendix: Quantifying Inertia Response of ESR

To estimate the inertia response of an ESR, the swing equation can be used.

$$\frac{2H}{f_n} = \frac{\Delta P}{df/dt}$$

Where:

H is the equivalent inertia constant of the ESR in s,

f_n is the nominal frequency,

ΔP is the change of output power in pu based on the ESR MVA rating,

df/dt is the rate of change of frequency (RoCoF) in 1 Hz/s.

By changing the frequency of the controllable voltage source with a fixed rate, the output active power is changing as well. Therefore, the average ΔP (ΔP_{av}) during the study time is used for quantifying the inertia constant:

$$H = 0.5 f_n \frac{\Delta P_{av}}{df/dt} = 0.5 f_n \frac{\frac{1}{T} \int_{t_0}^{t_0+T} \overbrace{\Delta P(t)}^{\Delta E} dt}{df/dt} = 0.5 f_n \frac{\Delta E/T}{df/dt} [s],$$

Considering, $f_n = 60$ Hz, $df/dt = 1$ Hz/s, and $T = 0.5$ s, then:

$$H = 60 * \Delta E [s]$$