

Alliander System Operations: Managing Flexibility



Featuring:



Mitchel Haeve



Akhtar Hussain Javed



Mark Nigge-Uricher



Manuel Dakessian

For Q&A: Submit your questions at www.slido.com, event code **ESIG13**

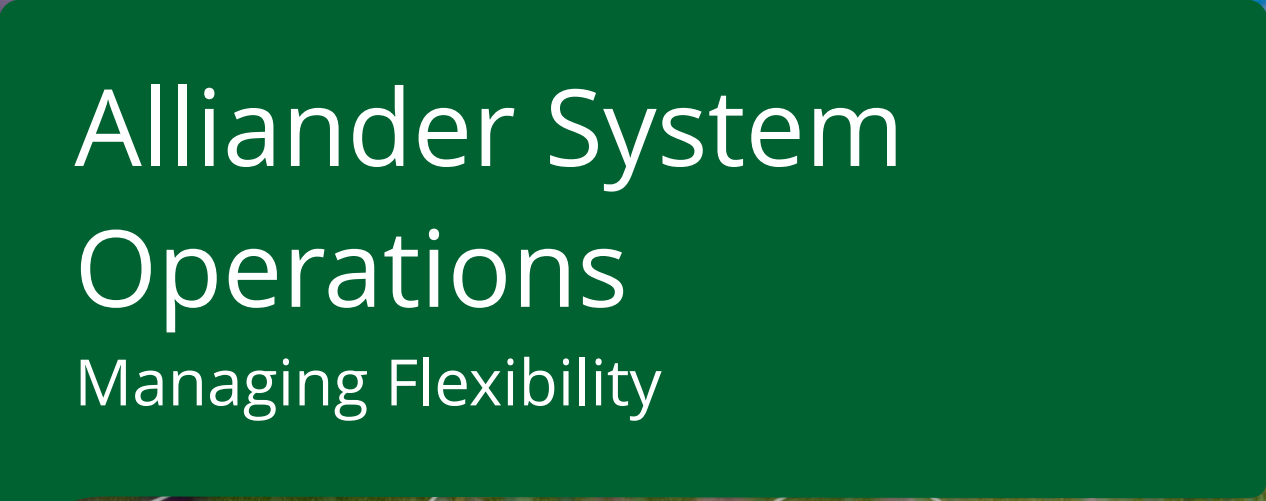
A dark green rounded rectangular box containing the title text in white.

Alliander System Operations

Managing Flexibility



Agenda

1. Intro
2. Strategy, policies and flexibility framework
3. Our Given World
4. Our Self-Made World
5. Demo
6. Q&A



Alliander, a network company



Our service area



Electricity grid length

93,000 km

92,000 km in 2020

Gas grid length

42,000 km

42,000 km in 2020

2024 in numbers

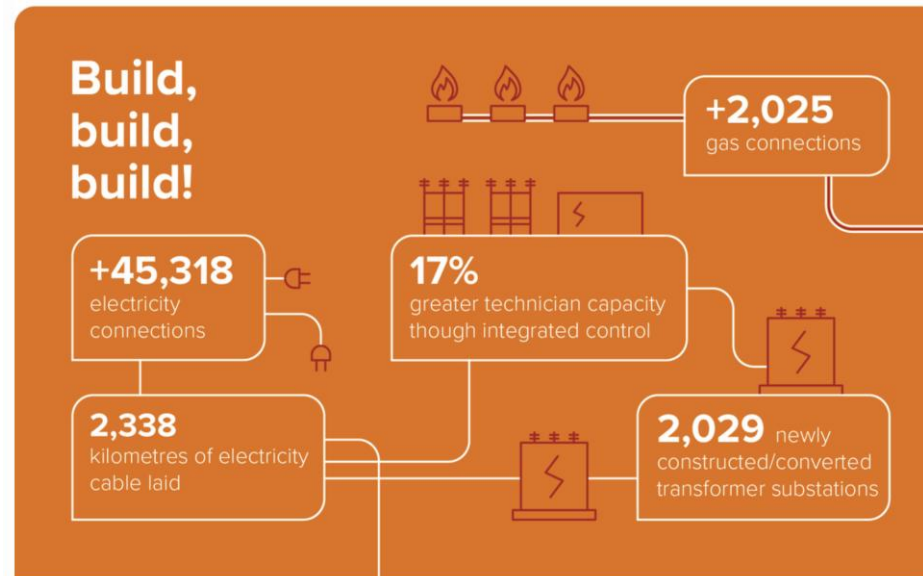
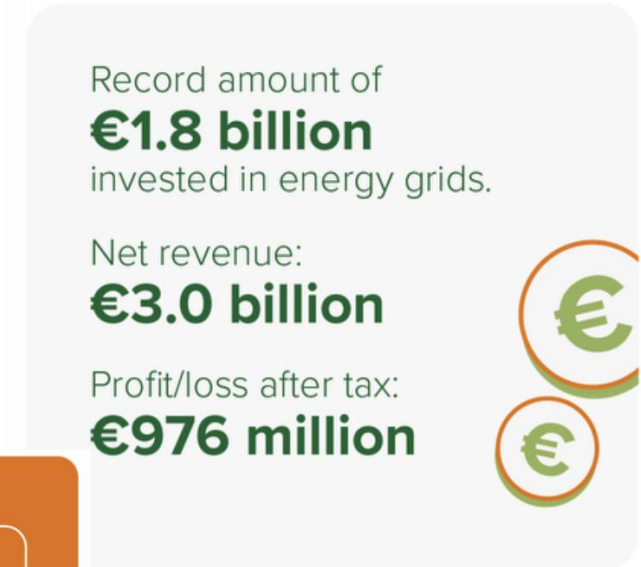

Where do the Dutch stand today

The demand for electricity is growing faster than our existing grid can accommodate

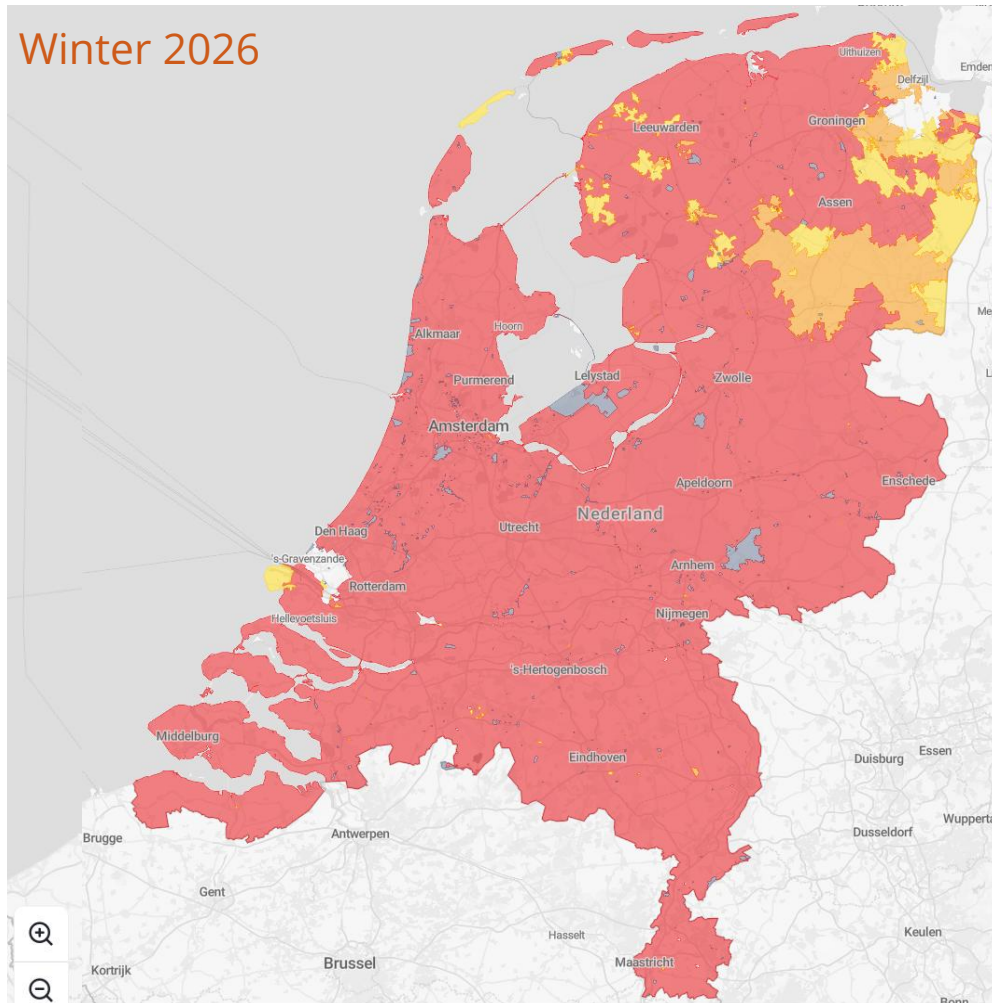

Consumption

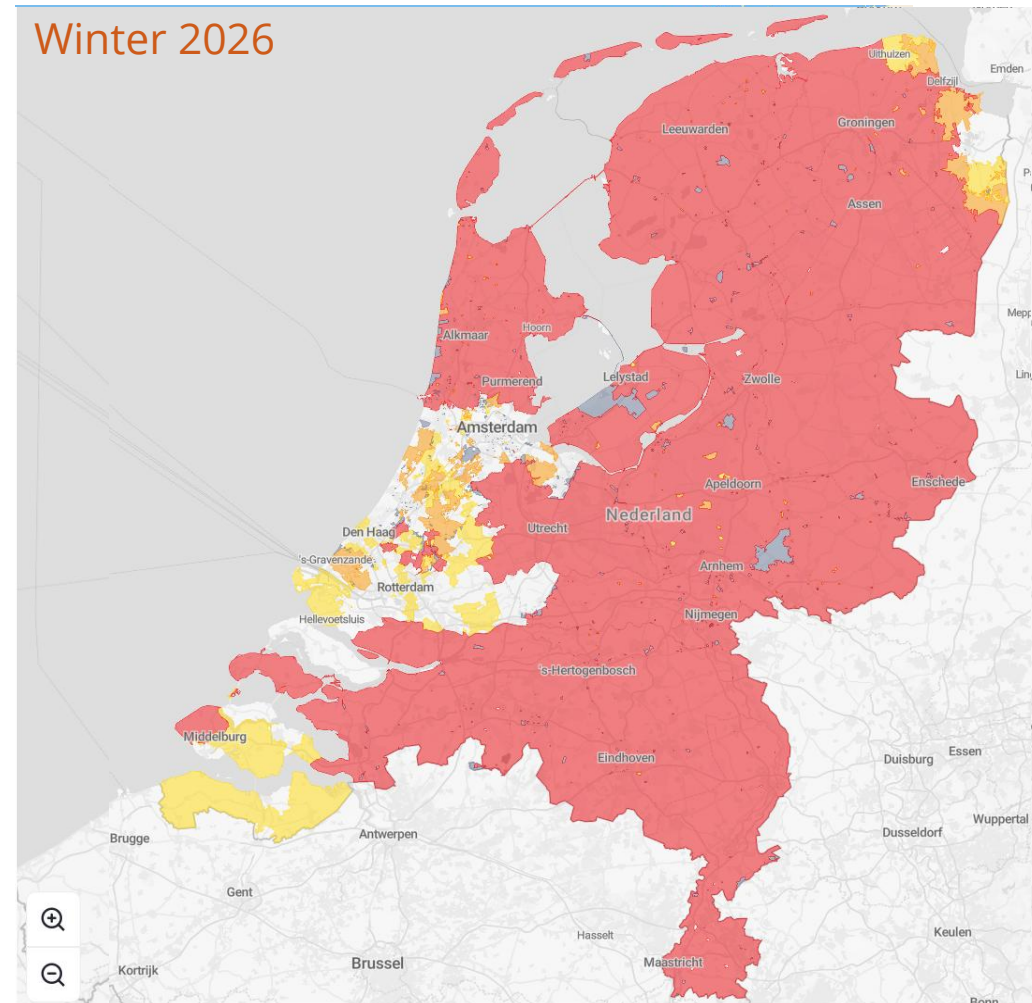

Generation

Impact of the energy transition

The share of renewables in the Dutch grid is growing rapidly



Energy transition

Totals at year-end 2024

Charging stations
19,758

Customer requests for renewable generation
1,100

CO₂ emissions
446 kt

Solar energy
8,247

We expect that by 2030, approximately **19,000 customer requests** can no longer be accommodated in the current standard (firm) manner..

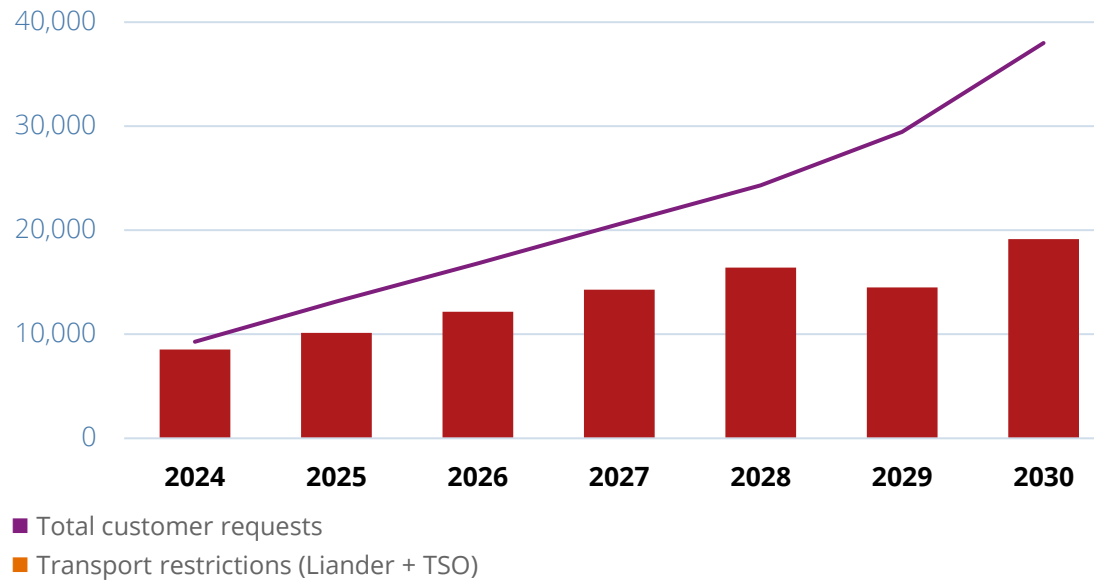

Source: INPAI-transportbeperkingenprognose 2025-Q1

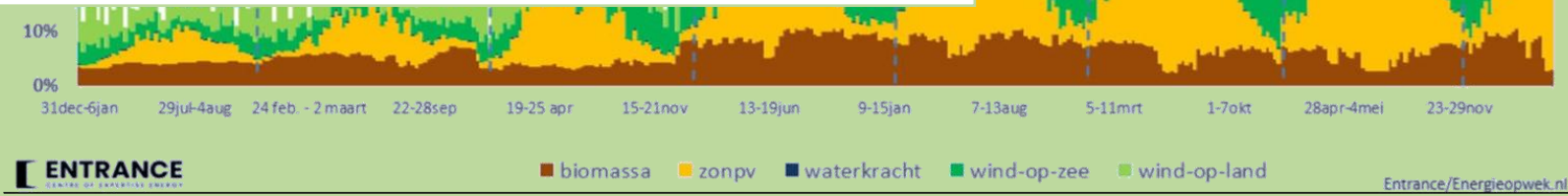
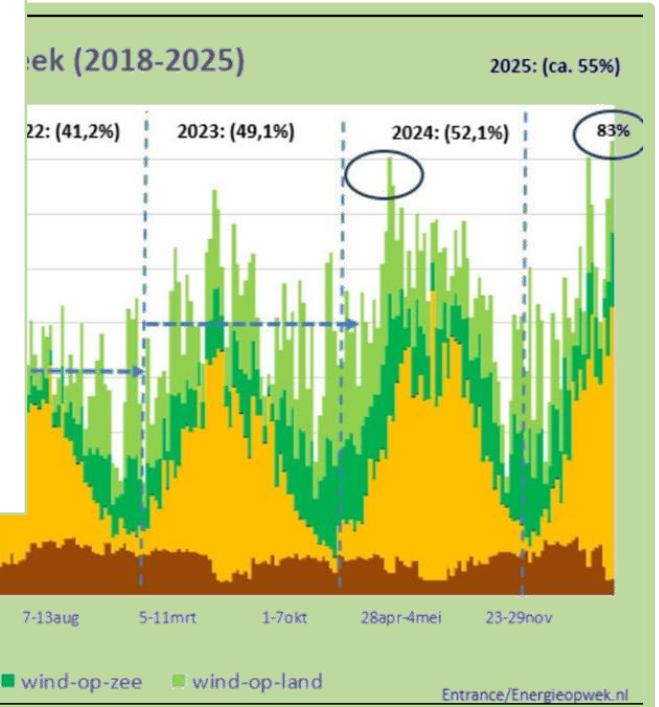

What does this mean for our customers?

Growing areas with constraints & increasing waiting customers



Aantal TB | per aansluitcategorie | per maand cumulatief

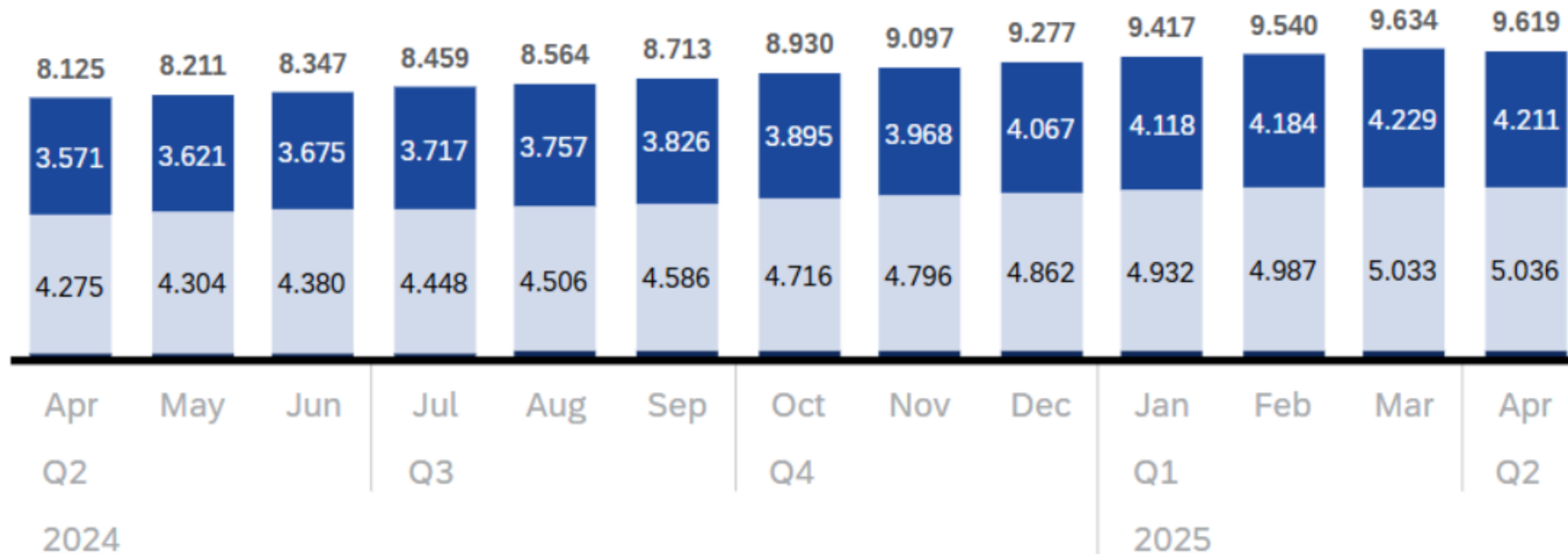

Transport restrictions Aantal transportbeperkingen

In bedrijf & opgelegd

9.619

Δ vorige maand

-15

Connections w/ transport restrictions

% Aansluitingen met een transportbeperking

In bedrijf & opgelegd

20,9%

Providing timely solutions to accelerate the development and sustainability of the Netherlands

- 1 Excellent grid management: optimising maintenance & improving customer service
- 2 Reduce demand for transport capacity
- 3 Better use of the net
- 4 Create more work
- 5 Data sharing & development of new market services
- 6 Developing infrastructure for heat and sustainable gases
- 7 Future-proof foundation

GOAL 2030
In 2030, with our energy grids and market facilitation, we offer our customers, governments and partners timely solutions that fit within an affordable and reliable energy system and accelerate the development and sustainability of the Netherlands.



Journey from DNO to DSO

We are growing our capabilities

- As we evolve from being DNO to DSO we expand our role beyond infrastructure stewardship.
- We operate in broader energy system where capacity management and interactions with the market becomes a core business area.
- The shift requires us not only to manage physical asset and grid constraints but also actively coordinating with market actors and customers.

alliander

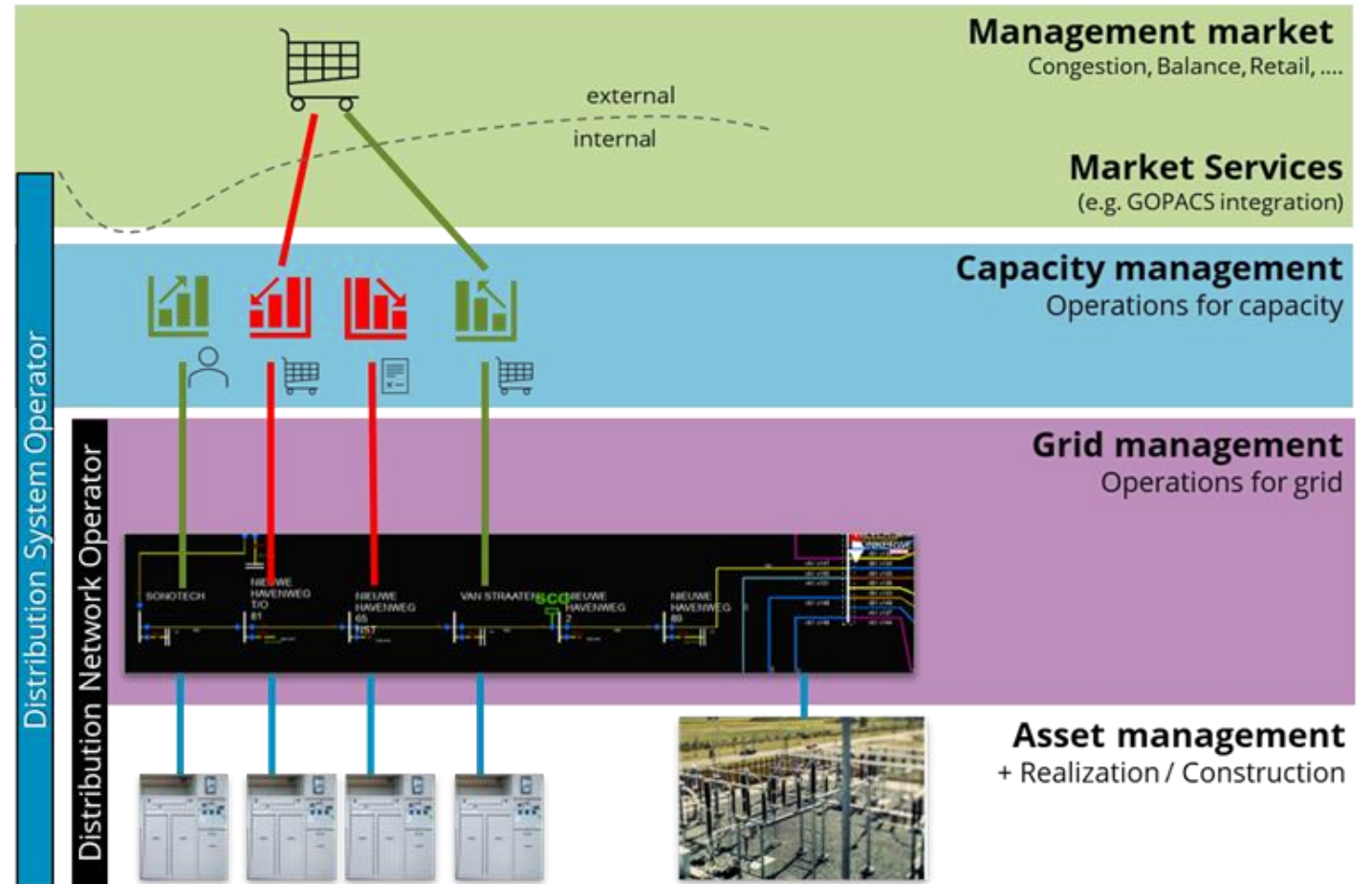

Timeline of Congestion Management Regulations



National Action Program (LAN)

More, faster, better and more flexible

The logo for Alliander, featuring the word "alliander" in white lowercase letters on a green rectangular background with a dark red horizontal bar below it.

1. **Faster Grid Expansion (“Sneller bouwen”)**

- Use integrated approach to accelerate construction and planning of grid upgrades.
- Adopt an approach in which grid extension projects are managed collaboratively by provinces, national government and the grid operators.

2. **Better Use of Existing Grid (“Sterker sturen”)**

- Improve rules, contracts, and tariffs to optimise grid capacity.
- Implement and monitor new regulations (Netcode Elektriciteit) for congestion management, including incentives or requirements for users to reduce peak demand.
- Develop flexible and time-bound contracts; explore new tariff structures to encourage off-peak usage.

3. **Increase Flexible Capacity (“Vergroten flexibele capaciteit”)**

- Encourage flexible energy use in industry and business (e.g., shifting consumption, using storage).
- Promote solutions which will allow for more flexibility for example, energy hubs.

Priority framework for customer intake

Social priority framework for customer connection

1. A new prioritization framework for the grid connections.
2. Distinction between small and large consumers is being removed: societal functions determines the priority.
3. The new legislation also gives rules how to reserve capacity for the housing or other projects.

1 Congestion Mitigators

Parties in this category help reduce grid congestion. Once connected, they provide extra transport capacity for other customers growth on our electriciteit



Criteria for Congestion Mitigators

- You are willing to use your full capacity flexibly at any time of the day (this is called 100% dispatchable)
- You have flexible capacity of at least 1MW

2 Safety

These are parties that contribute to safety in the Netherlands, such as the fire brigade, emergency medical care, ambulance services, judiciary, justice and



Contract for Congestion Management

If you meet the criteria for a congestion mitigator, you enter into a congestion management contract with your grid operator. Depending on the a capacity restriction contract or a redispatch cont.



3 Basic Needs

These are parties that provide basic needs such as education, drinking water, housing, and electricity/heat/gas,



National Regulation and Company Policy

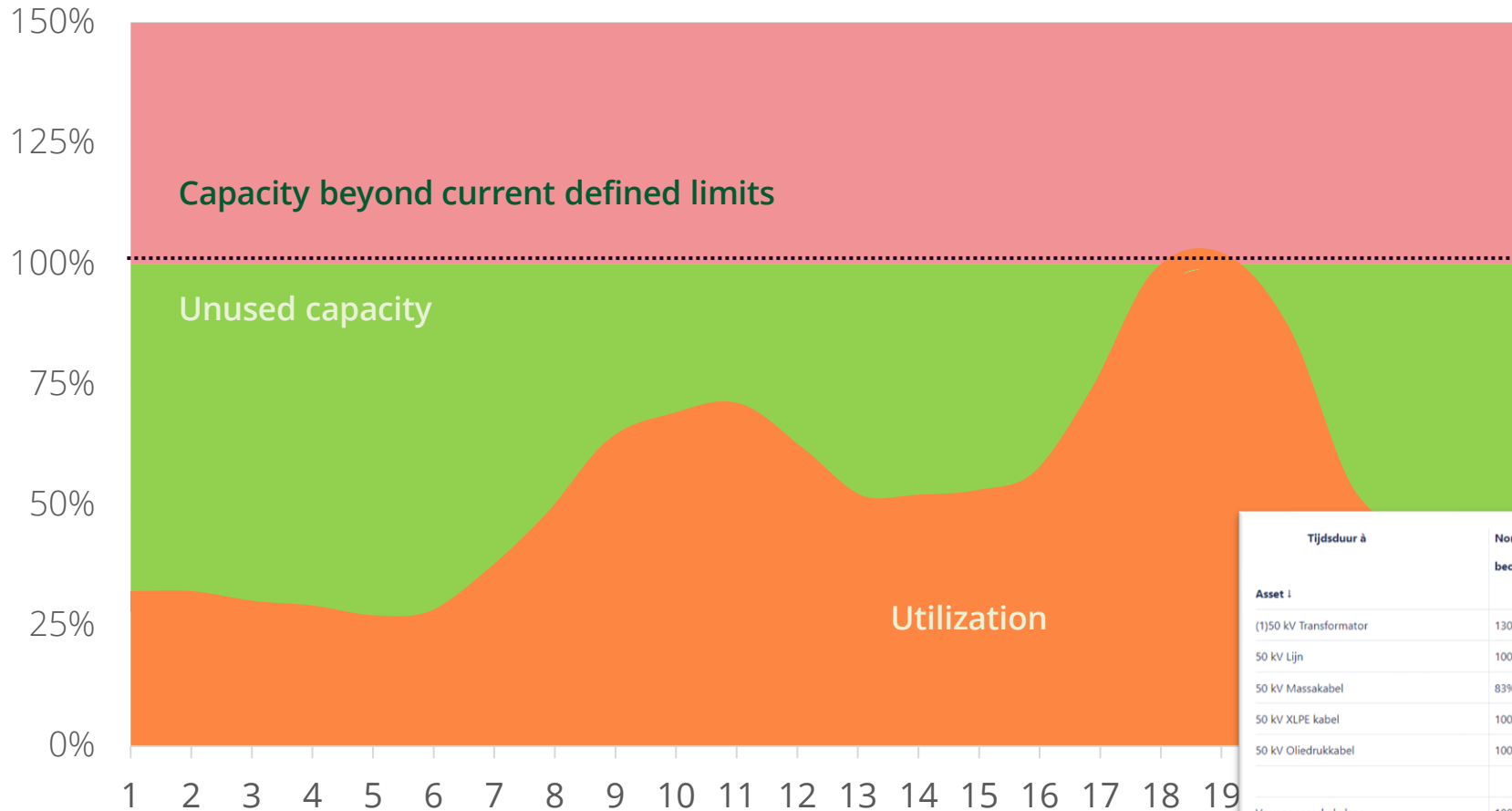

Bijlage 11 bij artikel 9.1, tweede lid: redispatch product >

Bijlage 12 bij artikel 9.1, eerste lid: capaciteitsbeperking product >

Bijlage 13 bij artikel 10.36, vierde lid: inkoopprocedure balanceringscapaciteit >

Bijlage 14 bij artikel 9.10, derde lid: onderzoeksrapport congestiemanagement >

bij artikel 10.17: indeling categorieën >

bij artikel 10.17: bepalen profiel fracties >

Tijdsduur à	Normaal bedrijf	n-1 bedrijf 0,5 uur
Asset i		
(1)50 kV Transformator	130%	130% cycli
50 kV Lijn	100%	100%
50 kV Massakabel	83%	115% cycli
50 kV XLPE kabel	100%	115% cycli
50 kV Oliegedrukkabel	100%	115% cycli
Vermogensschakelaar	100%	100%
Scheider	100%	100%
Stroomtransformator ⁷	120%	120%
MS GPLK	100%	115% cycli
MS XLPE	100%	115% cycli
MS distributie trafo, compact ruimte	110% cyclische belasting	
MS distributie trafo, betreedbare ruimte	120% cyclische belasting	



Flexibility framework

Customer intake till operations



Sweating the assets
Leaving redundancy
...

CLC-A
CLC-T
Group-CLC
...

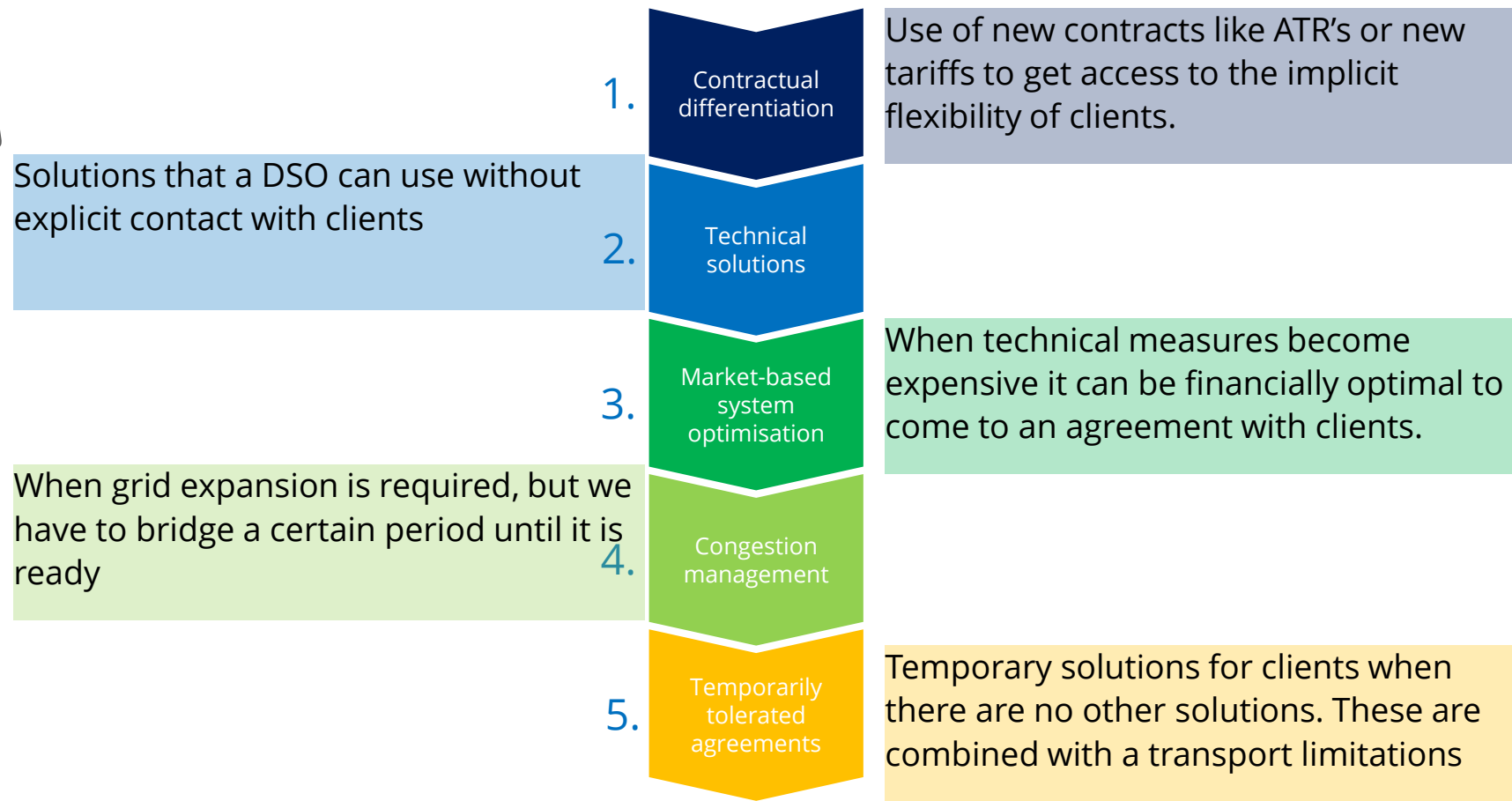

Time bound transport
Contract
Flexible connection agreements

DynT
AC5 LDN non-redundant

The 5 stages of grid management and GaaS



1. Extend grid

By introducing more grid components, we will reduce the amount of peaks

Future implementation in GaaS

2. Reduce frequency control impact

Overloads which are caused by frequency control get limited in congested areas

3. Use tariffs and alternative rights

We incentivize customers to use the grid when space is available using pricing strategies

Focus of this presentation

4. Use congestion management

We activate congestion management day-ahead and on intraday markets

5. Use real-time emergency steering

If needed, we curtail using real-time capacity management

System Operation capabilities

How we perform capacity management with GaaS



Process/progress assistance & UI (dashboard)



Core functionalities

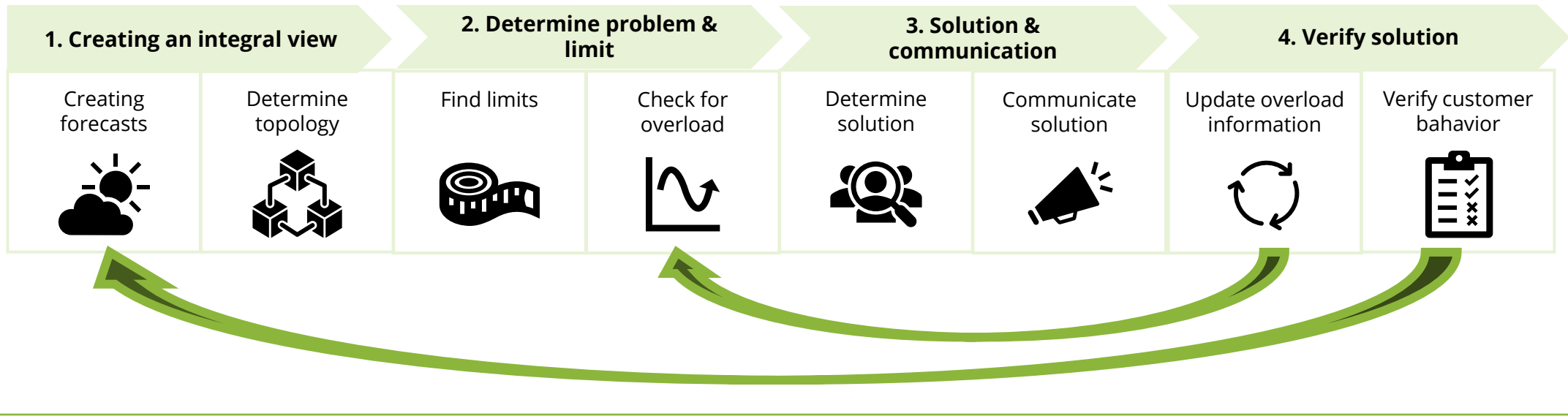

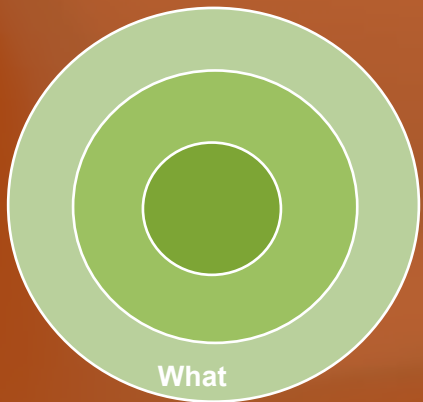

What we do in GaaS

Creating forecasts (1/3)

48 hours ahead prognoses on the bases of weather, historical data etc.

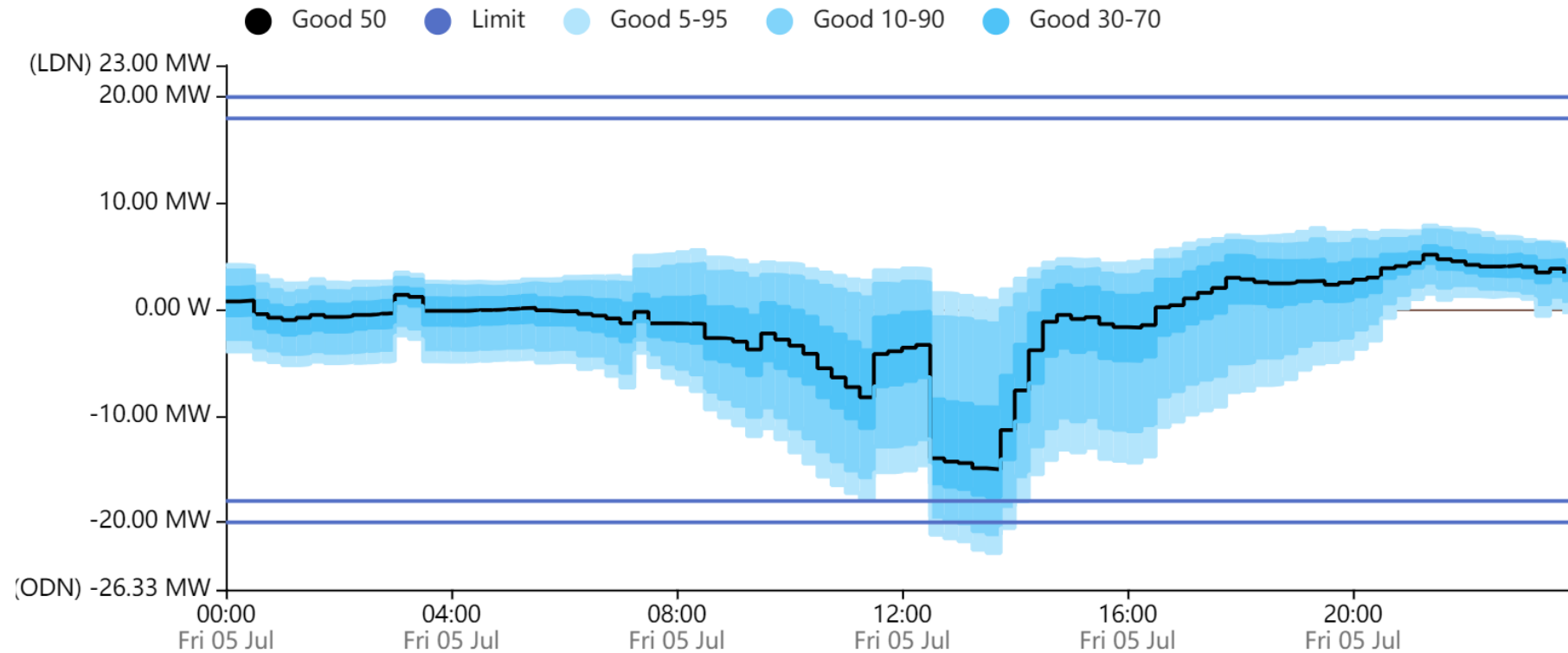

Creating forecasts (2/3)

The prognoses which is chosen influences the costs.

50th percentile at 13:00 shows a projected 14MW, large spread in quantiles.

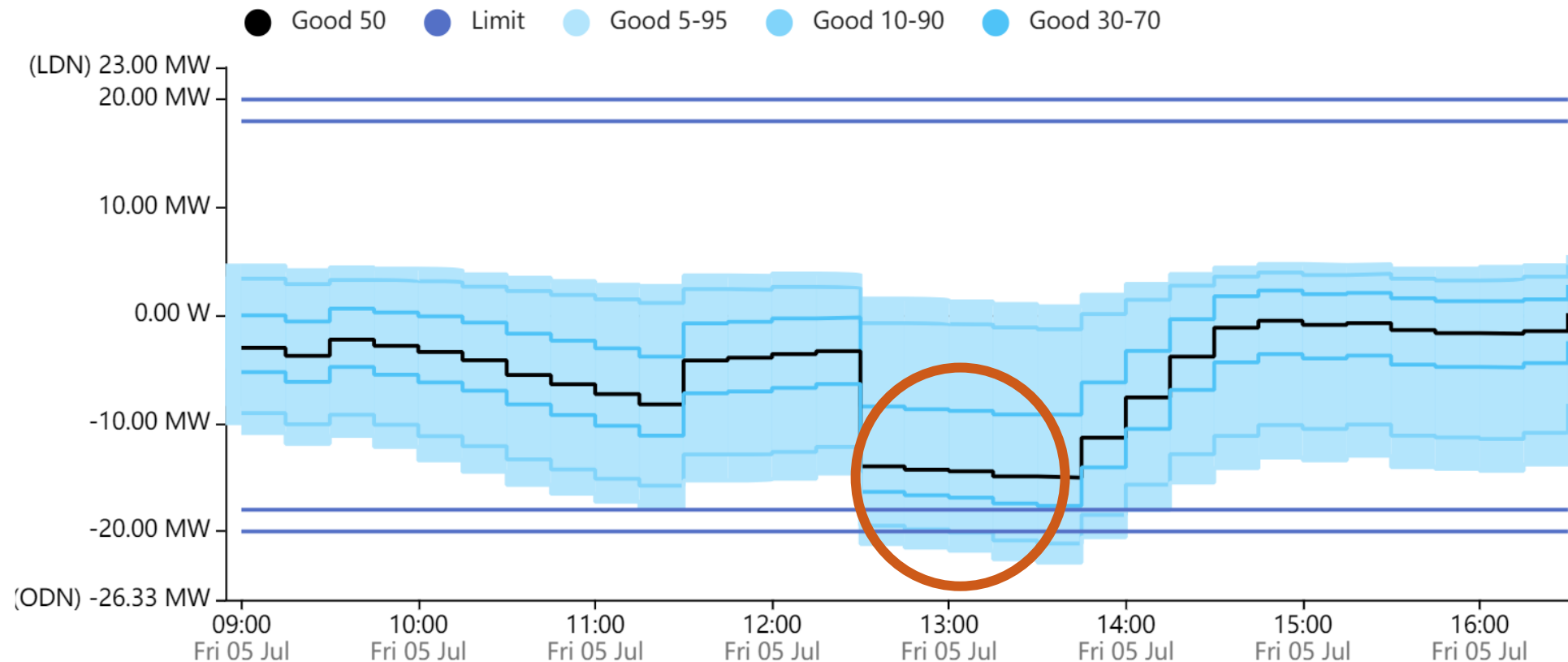

Creating forecasts (3/3)

Apparently, the weather resulted in less generation than expected. Forecasts are not always easy to make. 50th percentile at 13:00 shows a measured 9MW.

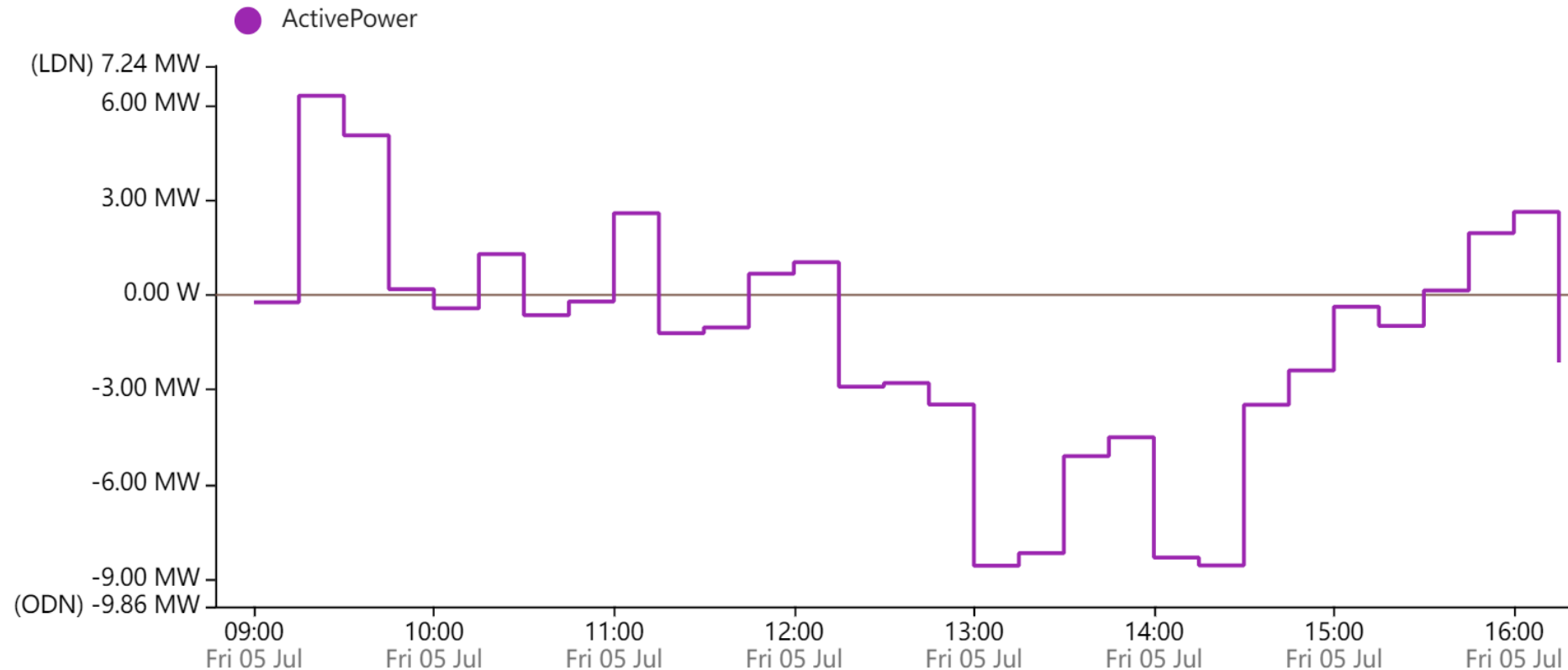

State estimation for medium voltage

For some components within our grid we do not have measurements, so we need to estimate the behavior to make forecast

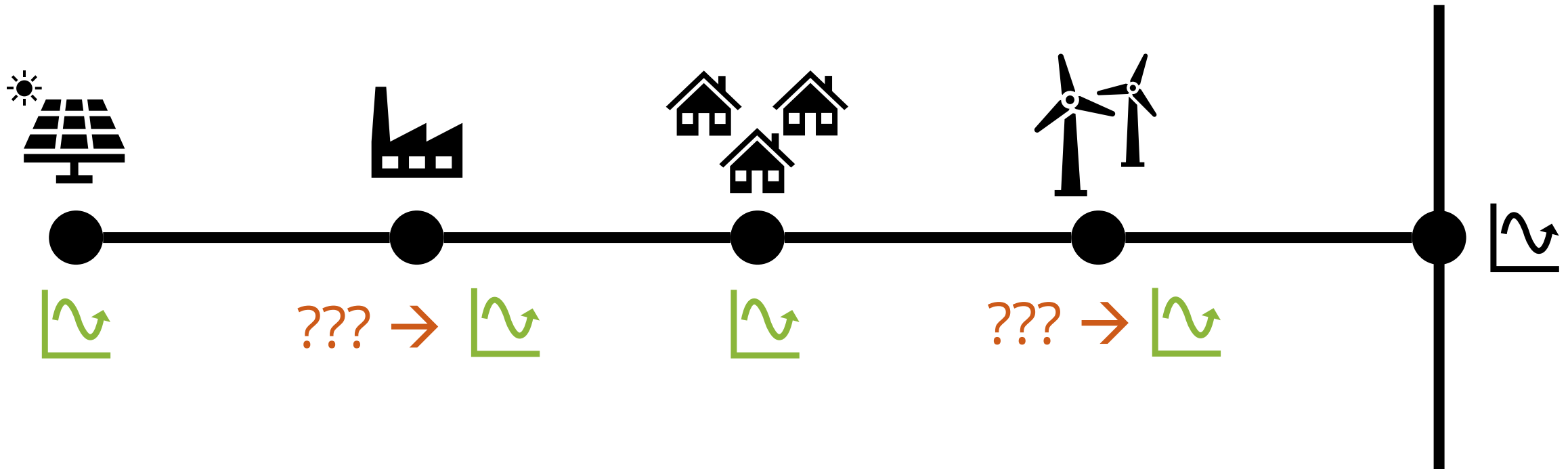

Determine topology

Routes can be changed based on maintenance or malfunction, or even due to the season.

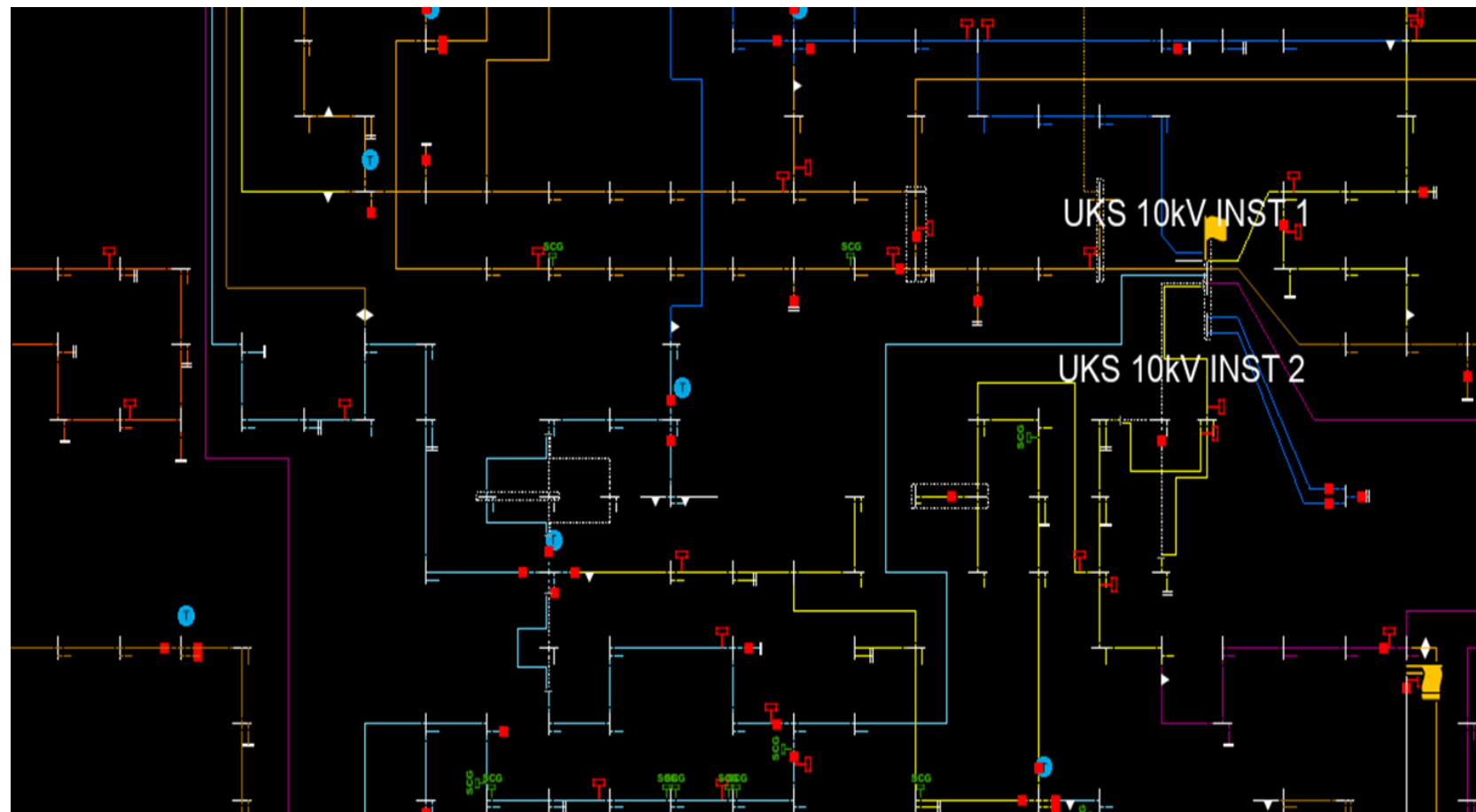

Find limits

The limit determines if we have an overload on certain stations, and action is necessary.

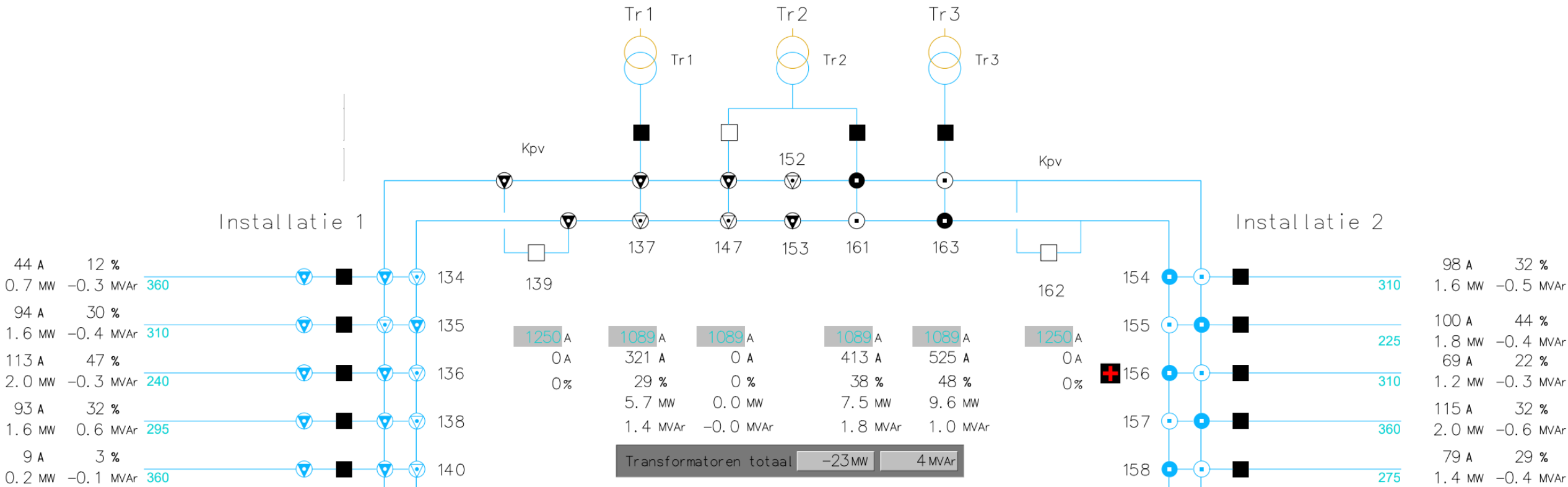

To determine overload

Using several limits, topology and forecasts, we assess for a possible overload.

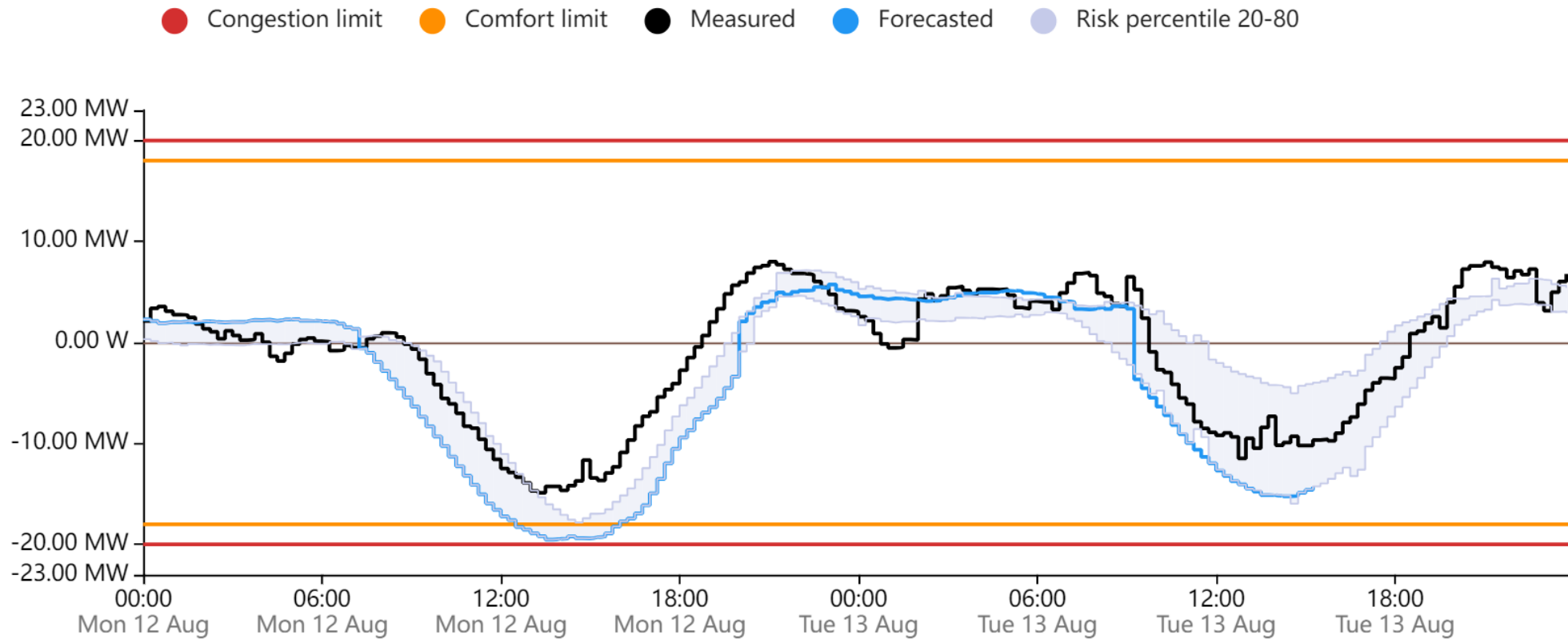

Power flow for medium voltage

We consider the forecast at any given time, to calculate the load on the cables using power flows

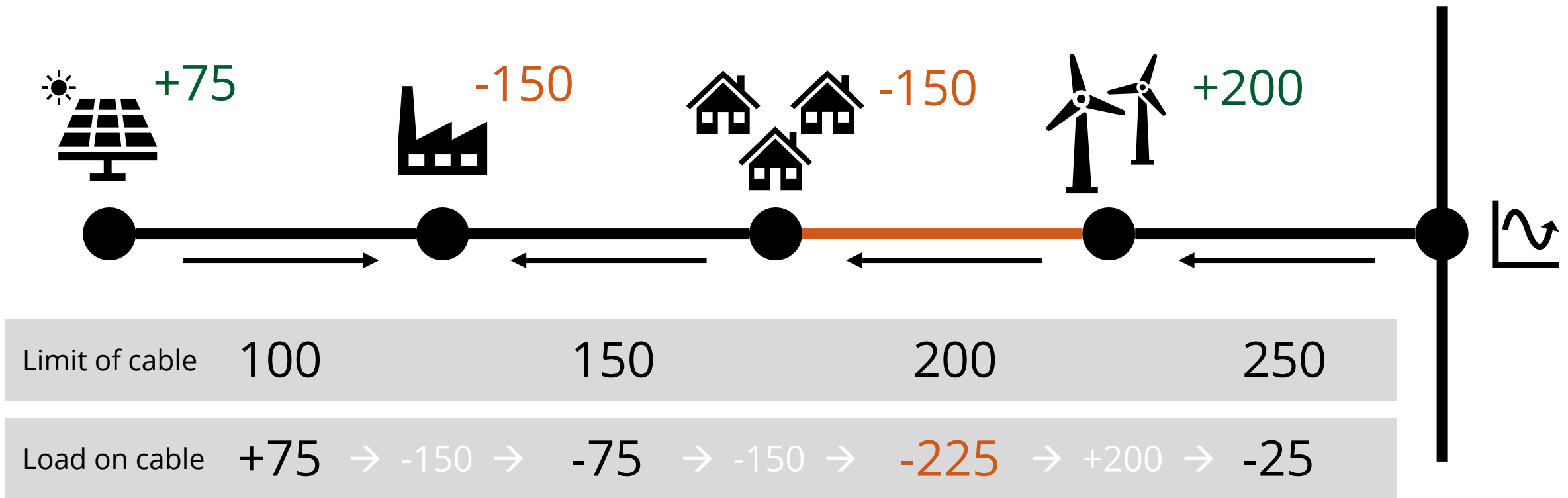

Determine solution: the energy market is a complex playing field

Grid balance is determined

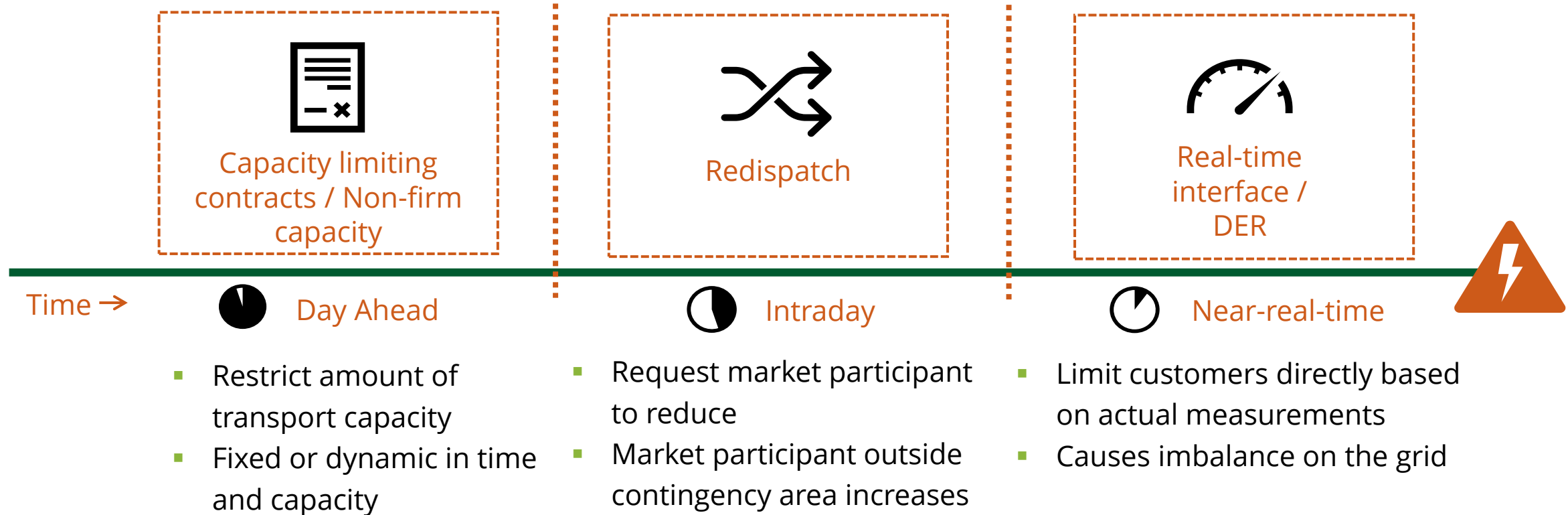

1. Creating an integral view

2. Determine problem & limit

3. Solution & communication

4. Verify solution

alliander

Find a solution which does not cause a new overload

After we have found a solution, we check if it indeed solves the contingency.

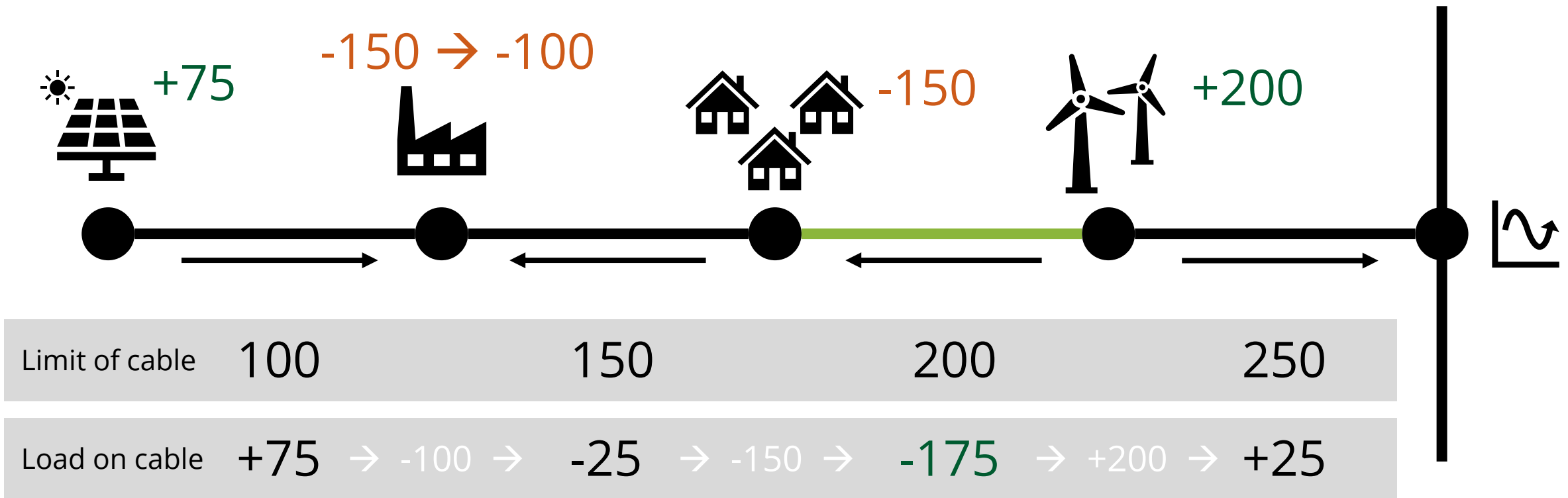

1. Creating an integral view

2. Determine problem & limit

3. Solution & communication

4. Verify solution

alllander

Verify customer behavior: invoice or fine (dependent on electricity markets)

The limit we imposed determines customer behavior. Check if the behavior is as imposed

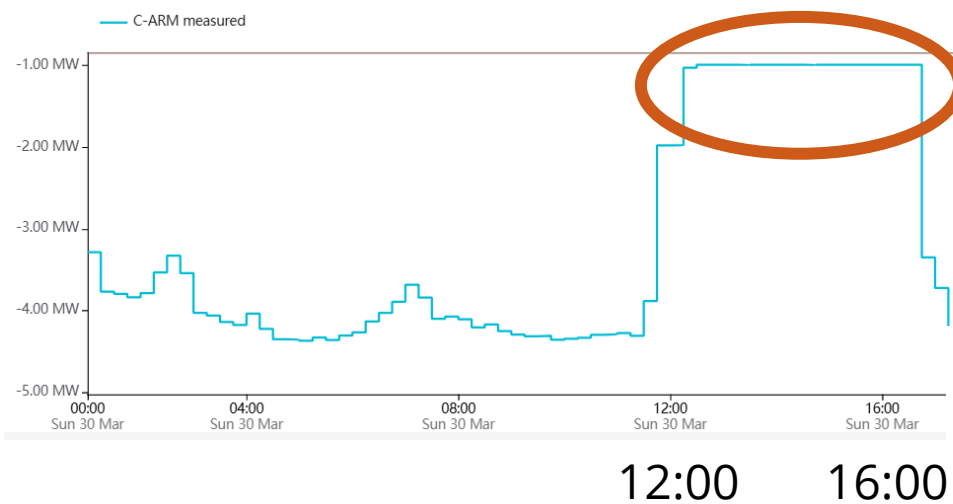

● Ok ● Exceeding ● Limit ● Limit Max ● Limit Min

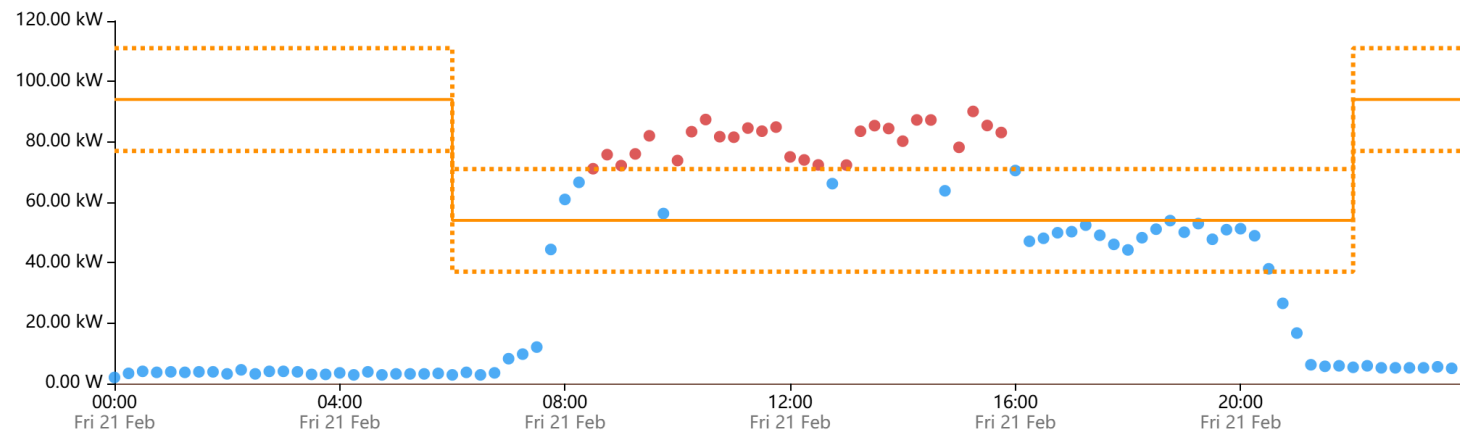

1. Creating an integral view

2. Determine problem & limit

3. Solution & communication

4. Verify solution

allliander

Verify if customer behavior influences the contingency load

We have seen a steering on the 30th of March. How did this effect our contingency?

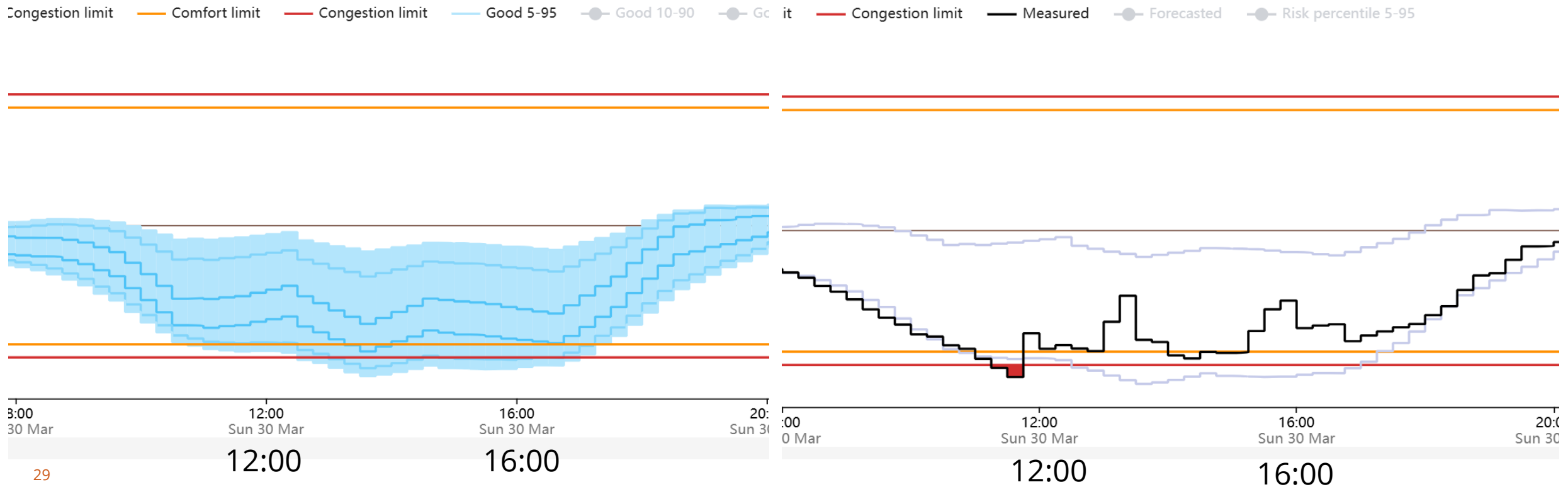

Tactical Capacity Management

Timehorizon and goal

Time horizon Tactical Capacity Management

Tactical Capacity Management (TCM) is the proactive monitoring and mitigation of capacity bottlenecks that arise in the medium term: between 7 days and 3 years

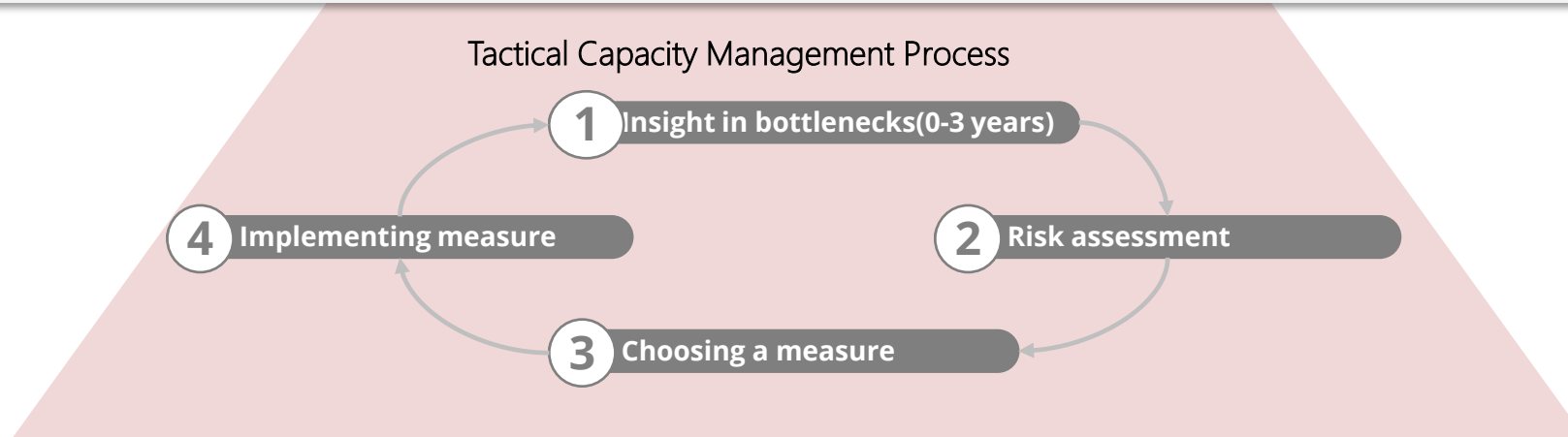

Tactical Capacity Management

Risk Assessment & Available measures



2 Risk assessment

3 Available Measures

Bidcomatix Netbeheerder/Netwerkbedrijf
scope: Bedrijfsonderdeel
datum: 10-08-2023

Categorie	Veiligheid	Kwaliteit van levering	Aant & Impact	Wet- & Regelgeving	Financieel	Duurzaamheid	Waarschijnlijkheid van voorkomen (per bedrijfswaard)				
							ZEER LAAG	LAAG	MIDDEN	HOOG	ZEER HOOG
Impact (op bedrijfswaarde / ruiming)	ZEER HOOG	Meerdere uren > 10.000.000 kWh	Beveiligings- of onderhoudswerkzaamheden op kritieke delen van het netwerk met lange duur	Invoering van nieuwe wetgeving, Overname van een bedrijf, Overname van een bedrijf met grote gevolgen voor de omgeving, Overname van een bedrijf met grote gevolgen voor de omgeving	afschrijven van de waarde van de investering	Uitbreiding van de capaciteit van de netwerken	M	H	ZH	ZH	ZH
	HOOG	Organiseren van een grote onderhoudswerkzaamheid met een impact van 1.000.000 tot 10.000.000 kWh	Beveiligings- of onderhoudswerkzaamheden op kritieke delen van het netwerk met korte duur	Overname van een bedrijf met grote gevolgen voor de omgeving, Overname van een bedrijf met grote gevolgen voor de omgeving	afschrijven van de waarde van de investering	Uitbreiding van de capaciteit van de netwerken	L	M	H	ZH	ZH
	MIDDEN, MEDIUM	Organiseren van een grote onderhoudswerkzaamheid met een impact van 100.000 tot 1.000.000 kWh	Beveiligings- of onderhoudswerkzaamheden op kritieke delen van het netwerk met korte duur	Overname van een bedrijf met grote gevolgen voor de omgeving, Overname van een bedrijf met grote gevolgen voor de omgeving	afschrijven van de waarde van de investering	Uitbreiding van de capaciteit van de netwerken	N	L	M	ZH	H
	LAAG	Organiseren van een grote onderhoudswerkzaamheid met een impact van 10.000 tot 100.000 kWh	Beveiligings- of onderhoudswerkzaamheden op kritieke delen van het netwerk met korte duur	Overname van een bedrijf met grote gevolgen voor de omgeving, Overname van een bedrijf met grote gevolgen voor de omgeving	afschrijven van de waarde van de investering	Uitbreiding van de capaciteit van de netwerken	N	N	L	M	H
	ZEER LAAG	Bijna onmogelijke onderhoudswerkzaamheid met een impact van < 10.000 kWh	Beveiligings- of onderhoudswerkzaamheden op kritieke delen van het netwerk met korte duur	Overname van een bedrijf met grote gevolgen voor de omgeving, Overname van een bedrijf met grote gevolgen voor de omgeving	afschrijven van de waarde van de investering	Uitbreiding van de capaciteit van de netwerken	N	N	N	L	M

Factors:

- Outage impact (# of clients)
- Financial impact
- Probability of the occurrence
- Safety Risk
- Expected Overload

- Increase asset utilization (Accept risk)**
Increase the congestion limit and optimize asset utilization without a significant risk of failure.
- Adjusting grid configurations**
Adjusting the grid configuration and transferring the load to a different station (load shedding)
- Flexibility deployment**
Making flexibility agreements with consumers and arranging for supply/return to be limited.
- Fast Track: Reprioritizing grid adjustments**
Bring forward planned structural grid reinforcement or maintenance
- Fast Track: temporary, pragmatic grid reinforcement**
Implementing a temporary technical solution

TCM – Collaboration between different departments



Role division in departments

- SO/LKC**
 - Monitor the bottlenecks
 - Make the risk assessment
 - Implement mitigation actions and activate flexibility
- SO/K&O**
 - Providing forecasts (grid development)
 - Conducting and approving supply chain studies
 - Contributing to mitigating measures
- APM AIM**
 - Investigating the reprioritization of network expansions in urgent situations
 - Coordination in TPRO
- APM INH / OT Hub**
 - Creating clarity and consistency regarding asset limits
 - Monitoring the asset's condition
- Market Services**
 - Finding flexible solutions
 - Contracting and communicating these
- Implementation chain**
 - Adjusting the schedule
 - Performing work

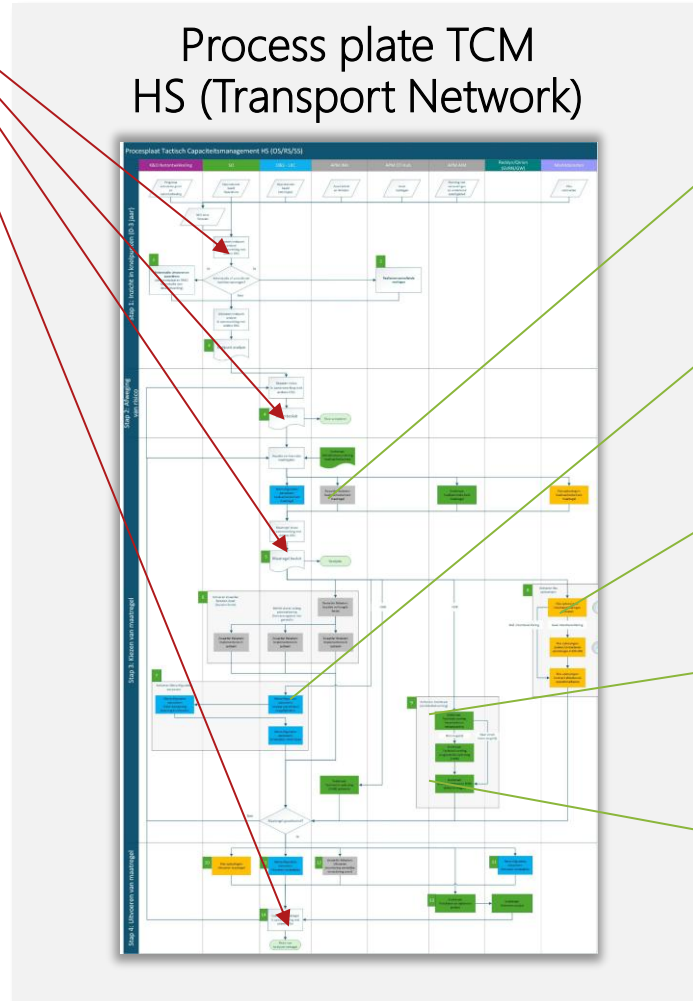

Examples of TCM HS measures

- Sweating the assets / Risk acceptance**

Increase the congestion limit or/and accept the risk under certain conditions
- Adjust network configurations**

LKC is investigating together with K&O NO whether the load on the stations can be adjusted (load shedding)
- Flex solutions**

Market services and SO investigate options for flexible solutions, and then conclude a contract
- Fast Track 1: Reprioritize work**

APM AIM and Reddyn investigate whether a grid adjustment can be carried out earlier and plan this where possible
- Fast Track 2: pragmatic solution**

K&O (Net Architect), APM AIM (Asset Project Manager), APM INH (Asset Manager), Reddyn (Portfolio Coordinator), and VMK (OIVer) are investigating whether a temporary technical solution is possible (such as the Wamel and Zwarte Paard cases).

Update Request: Accelerated replacement of feeder cable V.08 at RS Pioniersweg



Situation

- **RS Pioniersweg (RS Psw)**
- **Station capacity:**
 - N-1 (BZIV): **14.8 MVA**
 - N: **17.7 MVA**
- **Total connections**
 - Connections: 3401
- **Expected Load**
- **Measurements and loading factor**
 - 2022: **14 MVA**
 - 2023: **15.8 MVA**
 - 2024: **15.5 MVA**

Solution



Note: 1,6 km of the GPLK 3x95Cu cable with a Inom of 240A must be replaced with a suitable alternative cable with a Inom of 320A to alleviate the bottleneck in the RS Pioniersweg station. This pertains to field DNT V.08 which connects OS Dronnten with RS Pioniersweg.

Risk assessment: **Medium**

Risicomatrix Liander Assetmanagement							Kans van voorkomen (per bedrijfswaarde)				
							Mogelijk	Waarschijnlijk	Gevoelig	Jarlijks	Maandelijks
Impact op bedrijfswaarden							Meer dan 1 keer per 100 jaar	1 keer per 100 jaar tot 1 keer per 10 jaar	1 keer per 10 jaar tot 1 keer per 1 jaar	1 tot 10 keer per jaar	Meer dan 10 keer per jaar
Categorie	Veiligheid	Kwaliteit van levering	Klant & Imago	Wet- & regelgeving	Financieel	Doorzaamheid					
Reputatie	Meerdere doden	> 10.000.000 omv.	Grave schade aan het publieke vertrouwen van de klant	Belemmering van de energievoorziening	Schade van 100 tot 1000 euro	Uitval van 1 tot 10 keer per jaar	M	H	ZH	ZH	ZH
Ernstig	Ongeval met meerdere afstap of ernstig letsel	1.000.000 tot 10.000.000 omv.	Grave schade aan het publieke vertrouwen van de klant	Belemmering van de energievoorziening	Schade van 10 tot 1000 euro	Uitval van 1 tot 10 keer per jaar	L	M	H	ZH	ZH
Middel	Ongeval met ernstig letsel met materiële schade	100.000 tot 1.000.000 omv.	Middelzwaar schade aan het publieke vertrouwen van de klant	Belemmering van de energievoorziening	Schade van 1000 tot 10000 euro	Uitval van 1 tot 10 keer per jaar	N	L	M	H	ZH
Matig	Ongeval met letsel met materiële schade	10.000 tot 100.000 omv.	Middelzwaar schade aan het publieke vertrouwen van de klant	Belemmering van de energievoorziening	Schade van 10 tot 1000 euro	Uitval van 1 tot 10 keer per jaar	N	N	L	M	H
Klein	Een ongeval met geringe materiële schade	< 10.000 omv.	Wenig tot geen schade aan het publieke vertrouwen	Belemmering van de energievoorziening	Schade van 10 tot 1000 euro	Uitval van 1 tot 10 keer per jaar	N	N	N	L	M

Situation overview - SCADA view

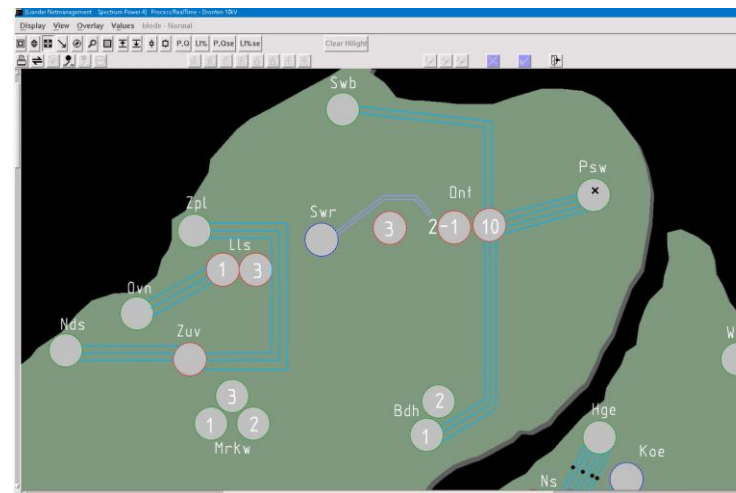

State estimation for medium voltage



For some components within our grid we do not have measurements, so we need to estimate the behavior to make forecast

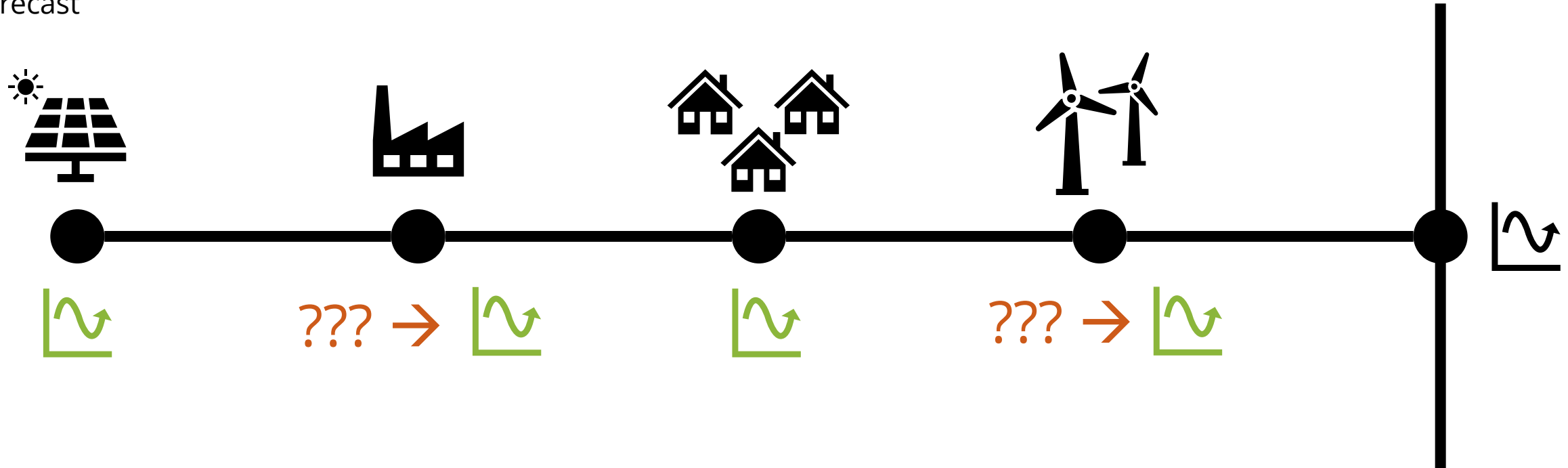



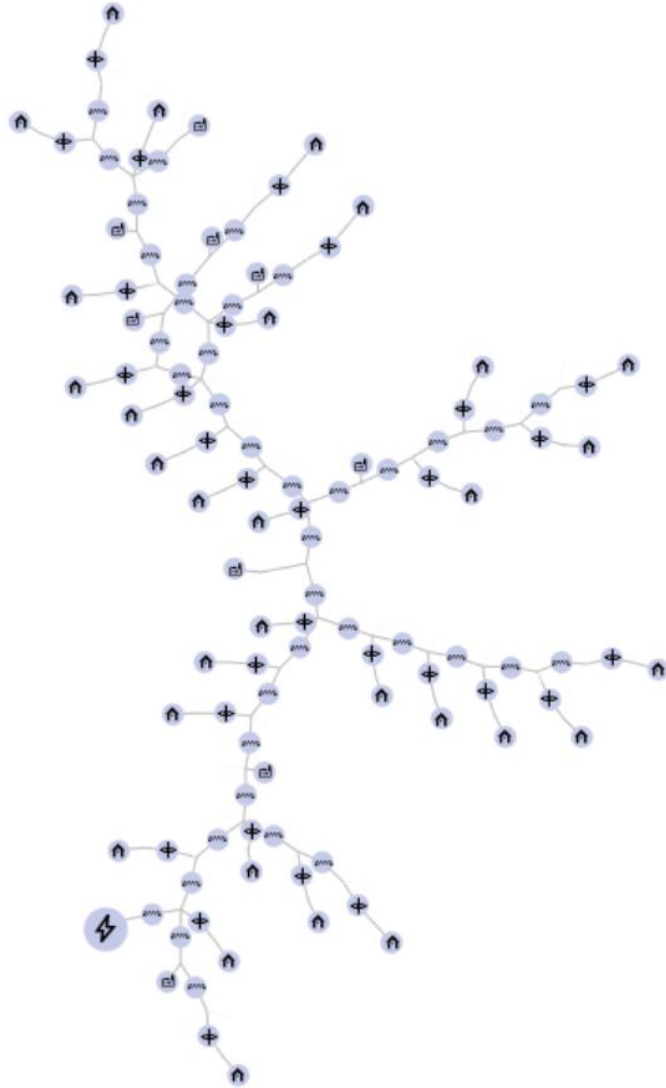

Estimates are made based on input of measurements, topology, power balance equations and equipment properties

State estimation for medium voltage





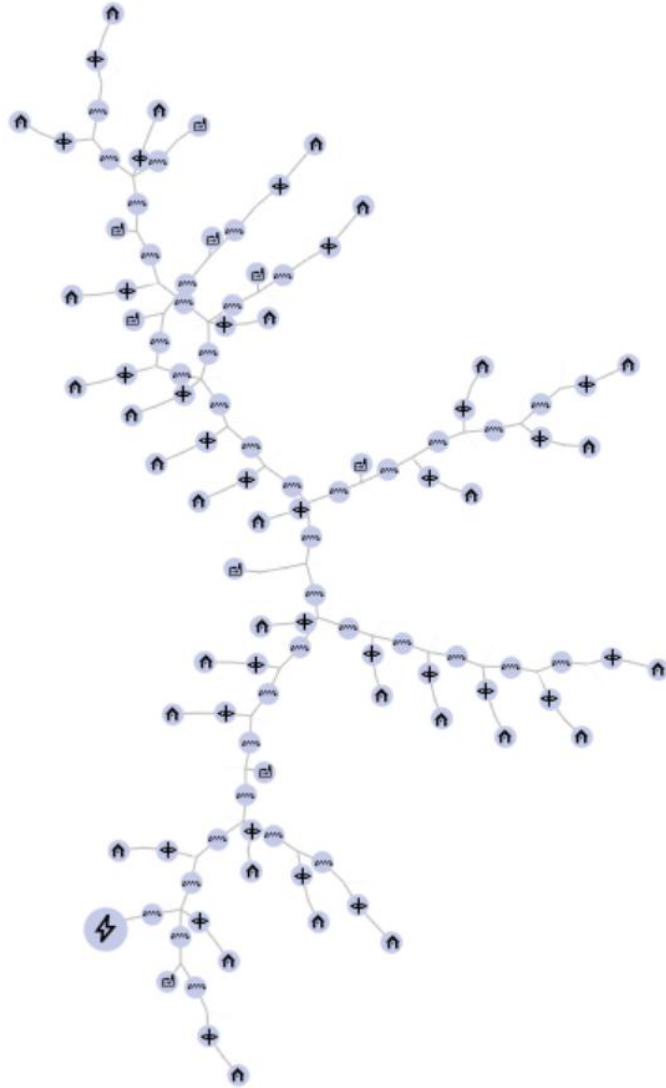

Equipment estimated continuously

-  Medium Voltage cable section
-  Low voltage busbar Section
-  Energy Connections
-  MV/LV Power Transformer
-  Energy Source Liander station

State estimation for medium voltage



Data input to state estimation process

-  5 min measured data from MV/LV Power Transformer
-  5 min measured EMS data in station for active power and voltage
-  Forecasts based on measurements from large consumers
-  Measurements at MV/LV connection points (45000 points only 10%)

State estimation for medium voltage

Forecasting at MV/LV connection points using aggregated smart meter data



Medium Voltage route

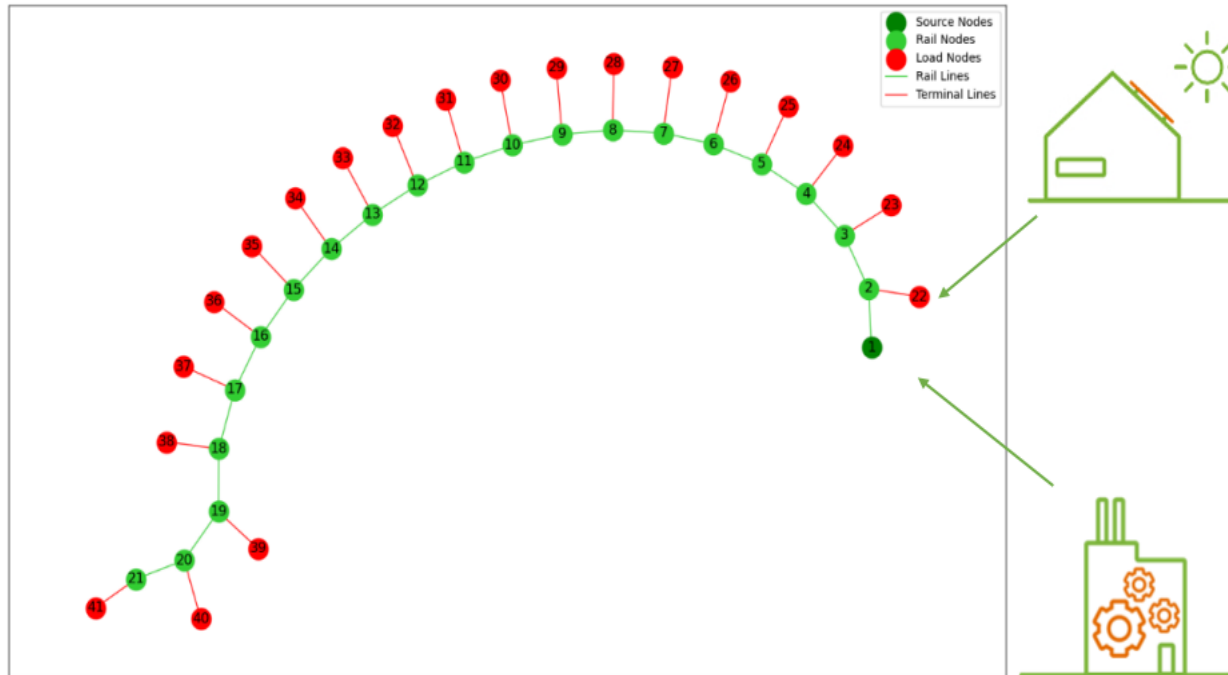

Low Voltage route (aggregating small connections)

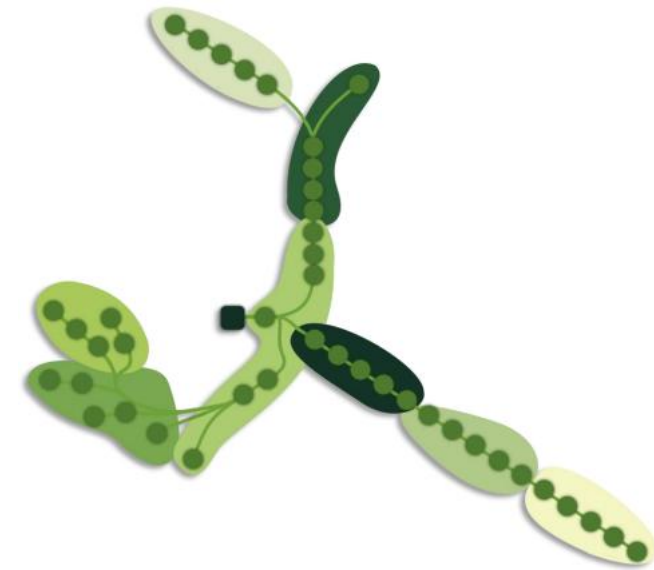

Results: Estimates vs Measurements



LS Meten vs BASMATI estimates over time

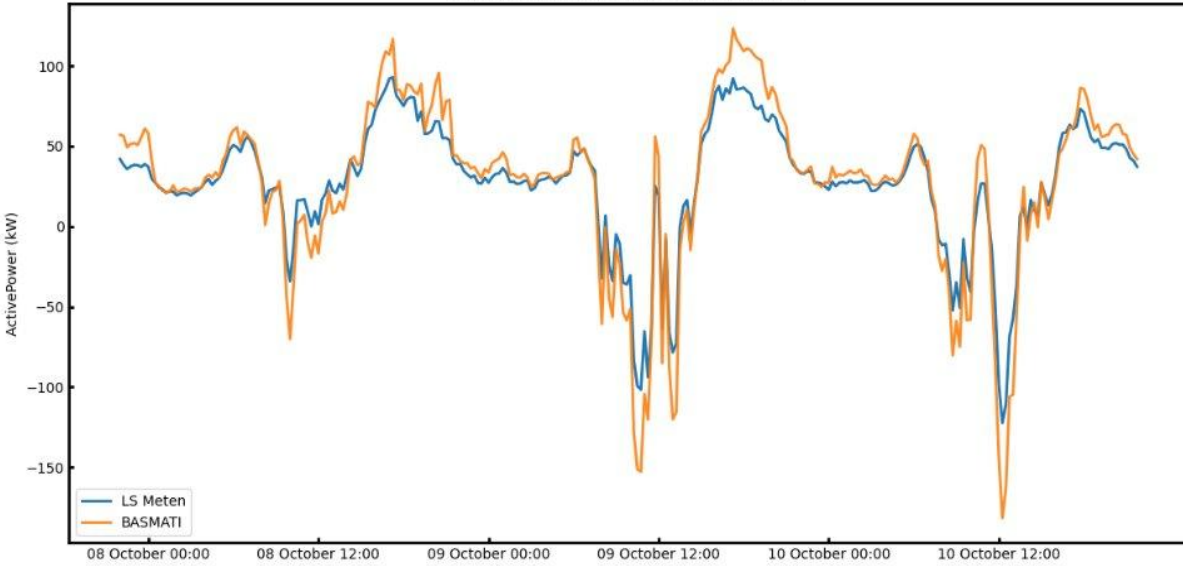

LS Meten vs BASMATI estimates over time

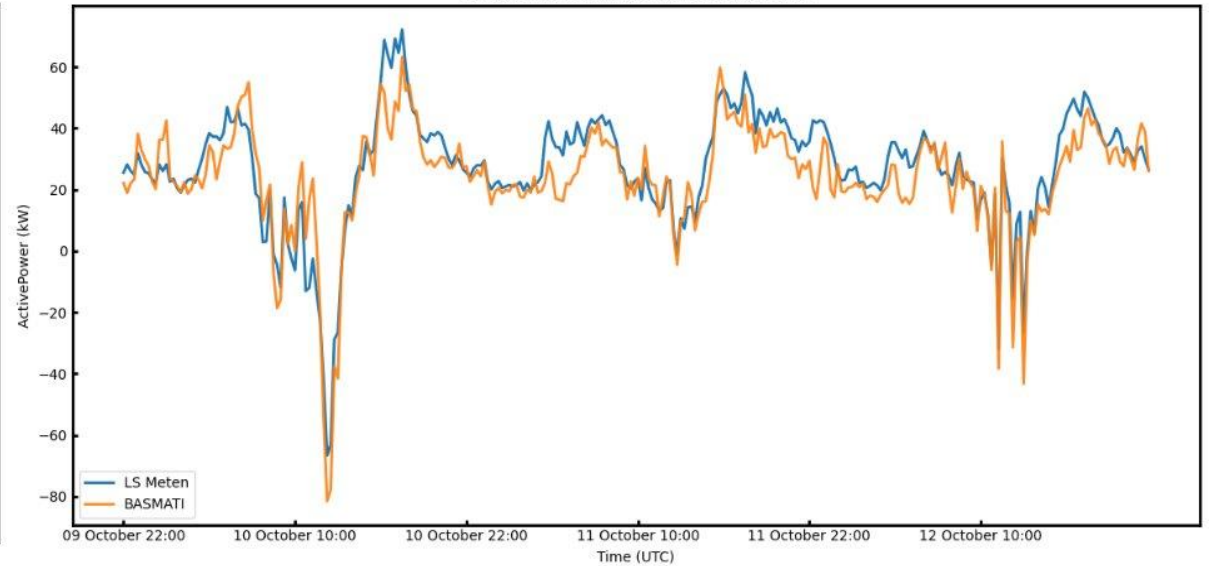

LS Meten vs BASMATI estimates over time

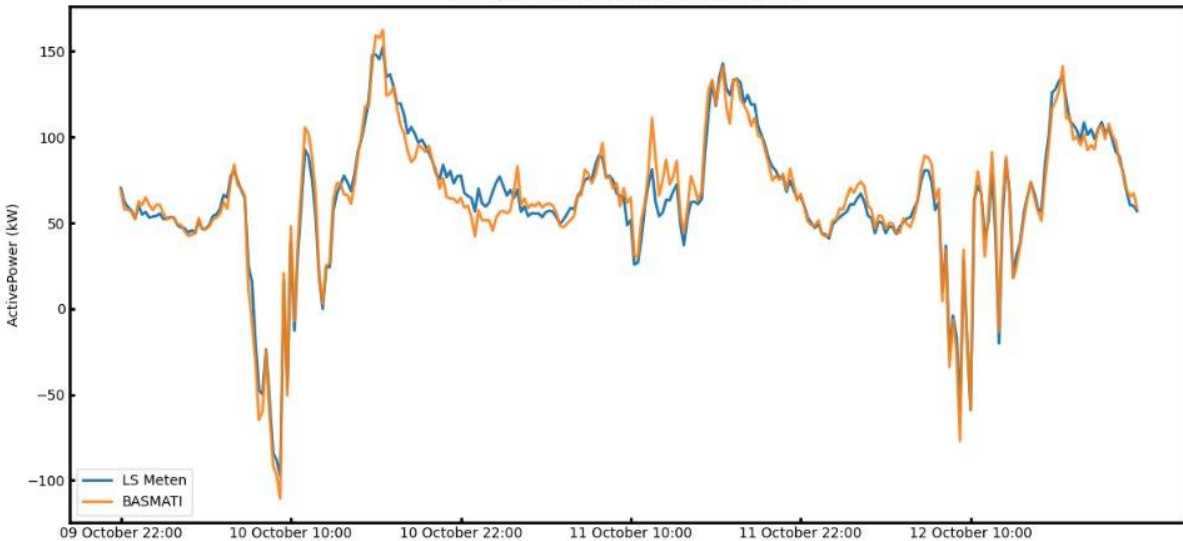

LS Meten vs BASMATI estimates over time

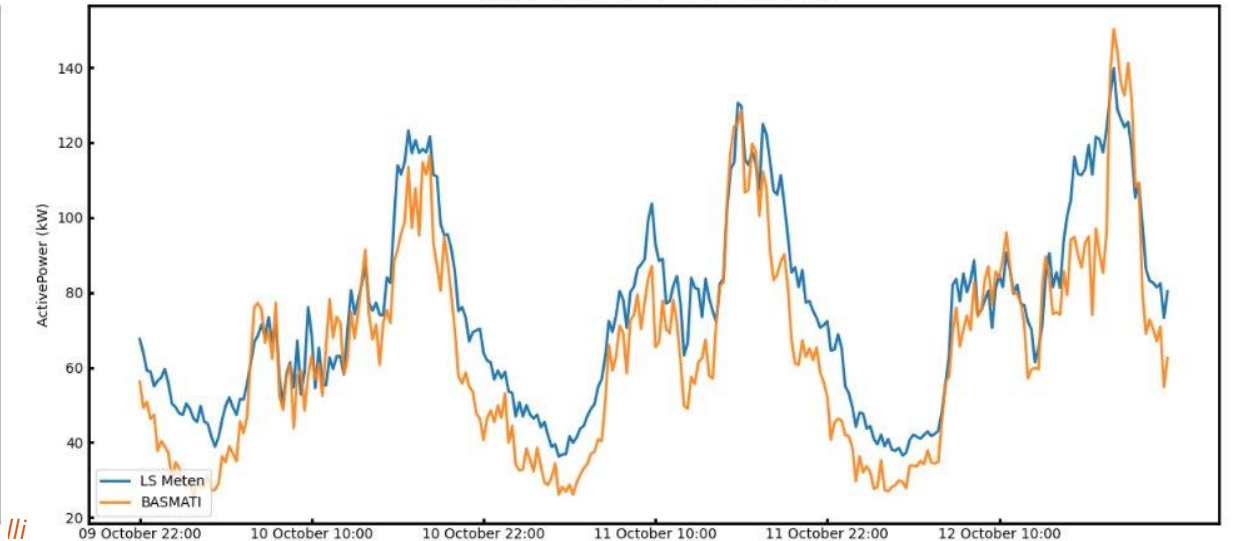

State estimation for medium voltage



5-min Realtime safety assessments

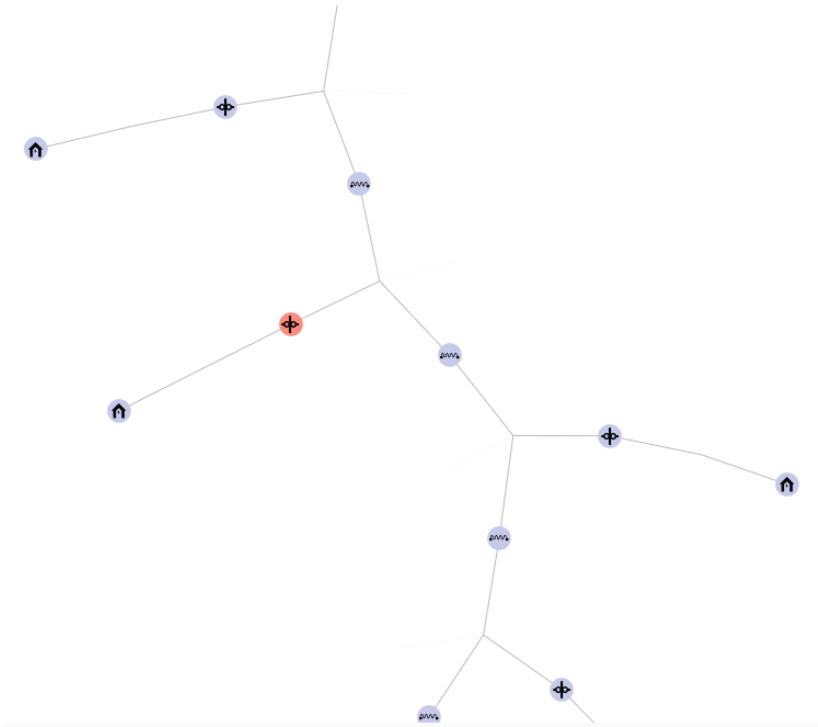

1005769-EL-T01-T01

Power transformer

General Overloads

Apparent power

Estimated overload 132.40 kVA

Terminal

1005769-EL-T01-T01_mv

Apparent power limit LDN 110.00 kVA

Estimated Transformer Overload

1005769-EL-T01-T01_mv

26 Nov 00:00 - 26 Nov 23:59

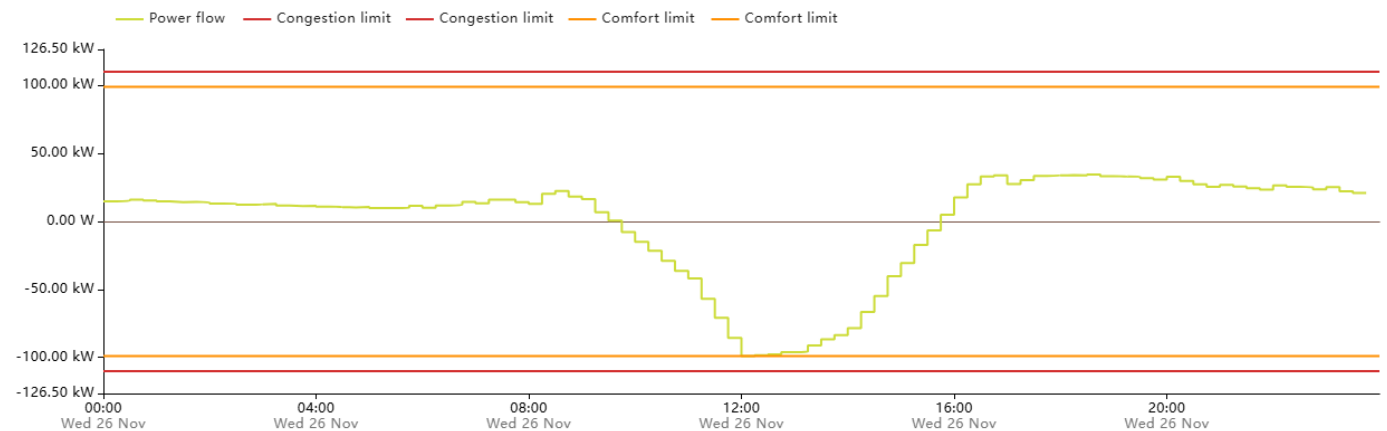

Live Demonstration



Gridmeister: [Cases - Gridmeister](#)

Congestion case High voltage substation: [Case Details - Gridmeister](#)

Congestion case Medium Voltage route: [Case Details - Gridmeister](#)

Your turn –
ask away!

alliander



Stay in contact with us:



Linkedin:



Email: Mark.Nigge-Uricher@alliander.com

Phone: +49 170 172 5402