



GFM Inverter Hardware Testing

Shahil Shah, Vahan Gevorgian, Przemyslaw Koralewicz,
Robb Wallen, Emanuel Mendiola, Weihang Yan

ESIG 2024 Spring Technical Workshop
Tucson, AZ

March 26, 2024

Outline

- 1** Hardware Testing Platform at NREL
- 2** Recent GFM Testing Projects at NREL
- 3** Quantifying System Needs for GFM Resources
- 4** Advanced Testing of GFM Resources
- 5** Summary

Megawatt-scale Hardware Testing Platform at NREL

NREL Flatirons Campus Test and Validation Platform

- Utility-scale wind
- Utility-scale PV
- Battery and H2 energy storage
- Loads
- Controlled grid
- Synchronized measurements:
 - 50kHz MVDAS, PMUs, facility meters
- Communications
- Automated experiment configuration

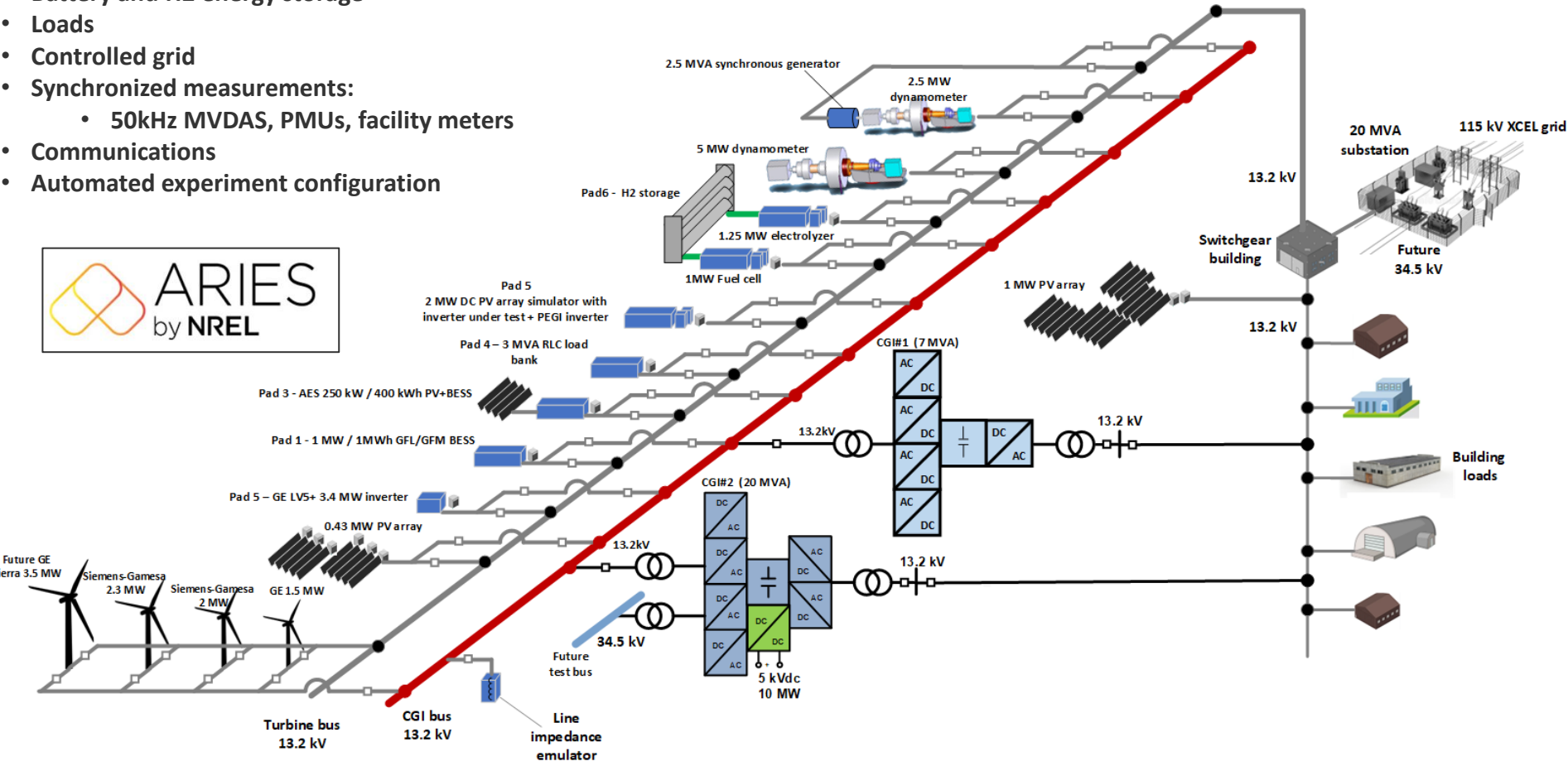

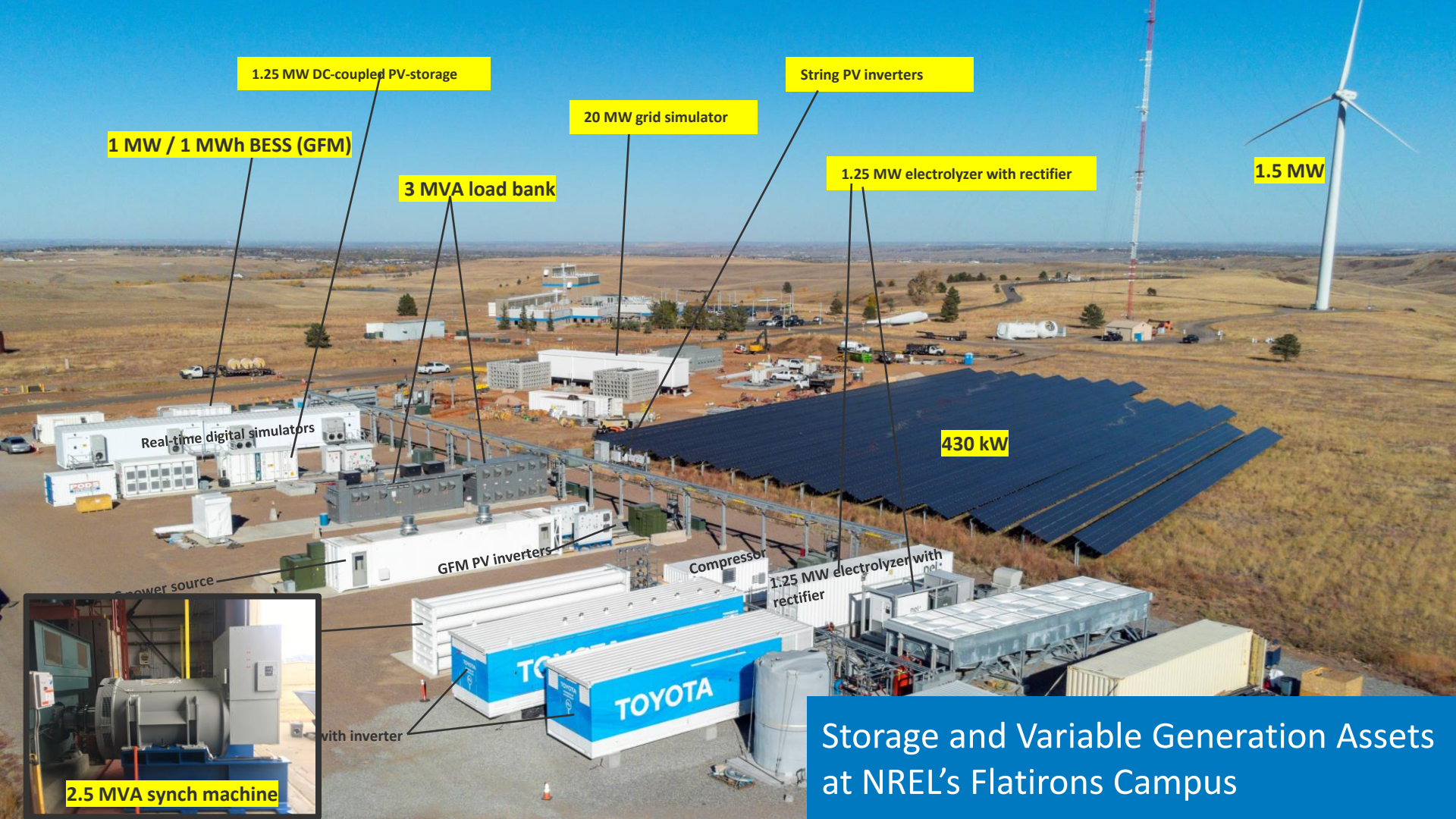

1.25 MW DC-coupled PV-storage

String PV inverters

1 MW / 1 MWh BESS (GFM)

20 MW grid simulator

1.25 MW electrolyzer with rectifier

1.5 MW

3 MVA load bank

430 kW

Real-time digital simulators

GFM PV inverters

Compressor

1.25 MW electrolyzer with rectifier

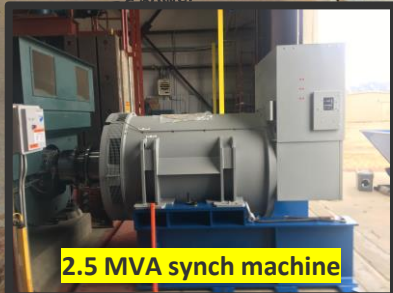

2.5 MVA synch machine

with inverter

Storage and Variable Generation Assets at NREL's Flatirons Campus

Controllable grid Interface

Power rating

- 7 MVA continuous
- 39 MVA short circuit capacity (for 2 sec)
- 4-wire, 13.2 kV

Possible test articles

- Types 1, 2, 3 and 4 wind turbines
- PV inverters, energy storage systems
- Conventional generators
- Combinations of technologies

Voltage control (no load THD <1%)

- Balanced and un-balanced voltage fault conditions (ZVRT and 140% HVRT) – independent voltage control for each phase on 13.2 kV terminals
- Response time – 1 millisecond (from full voltage to zero, or from zero back to full voltage)
- Long-term symmetrical voltage variations (+/- 10%) and voltage magnitude modulations (0-10 Hz) – SSR conditions
- Programmable impedance (strong and weak grids)
- Programmable distortions (lower harmonics 3, 5, 7)
- Impedance characterization of inverter-coupled generation
- Full STATCOM functionality

Frequency control

- Fast output frequency control (5 Hz/sec) within 45-65 Hz range
- 50/60 Hz operation
- Can simulate frequency conditions for any type of power system
- PHIL capable (coupled with RTDS)
- Test-bed for PMU-based wide-area stability controls
- **Test article impedance scan**

Controllable Grid Interface (CGI)

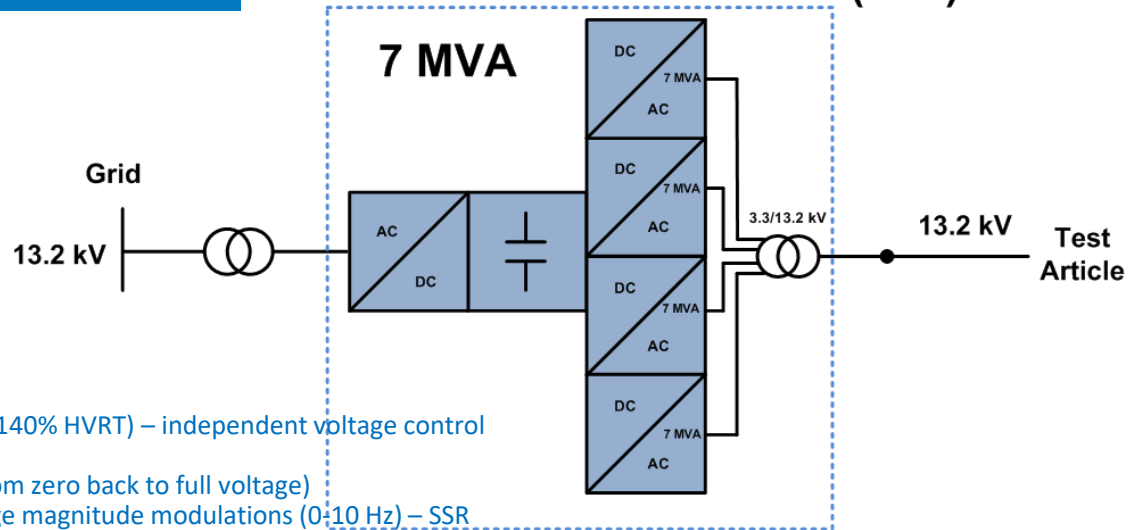

Less than 1 ms response time

Summary of CGI#2 Specifications

Power rating

- Continuous AC rating - 19.9 MVA at 13.2kV and 34.5 kV
- Overcurrent capability (x5.7 for 3 sec, x7.3 for 0.5 sec)
- 4-wire 13.2 kV or 35.4 kV taps
- Continuous operational AC voltage range: 0 - 40 kVAC
- Continuous DC rating – 10 MW at 5 kVDC

Possible test articles

- Types 1, 2, 3 and 4 wind turbines
- PV inverters, energy storage systems
- Conventional generators
- Combinations of technologies / hybrid systems
- Responsive loads

Voltage control (no load THD <1%)

- Balanced and unbalanced voltage fault conditions (ZVRT, LVRT and 140% HVRT) – independent voltage control for each phase on 13.2 kV and 34.5 kV terminals
- Response time – less than 1 millisecond (from full voltage to zero, or from zero back to full voltage)
- Programmable injection of positive, negative and zero sequence components
- Long-term symmetrical voltage variations (+/- 10%) and voltage magnitude modulations (0-10 Hz) – SSR conditions
- Programmable impedance (strong and weak grids, wide SCR range corresponding to a POI with up to 250 MVA of short circuit apparent power)
- Injection of controlled voltage distortions
- Wide-spectrum (0-2kHz) impedance characterization of inverter-coupled generation and loads
- All-quadrant reactive power capability characterization of any system

Frequency control

- Fast output frequency control (3 Hz/sec) within 45-65 Hz range
- 50/60 Hz operation
- Can simulate frequency conditions for any type of power system
- PHIL capable (can be coupled with RTDS)
- Coupled with PMU-based wide-area stability controls validation platform

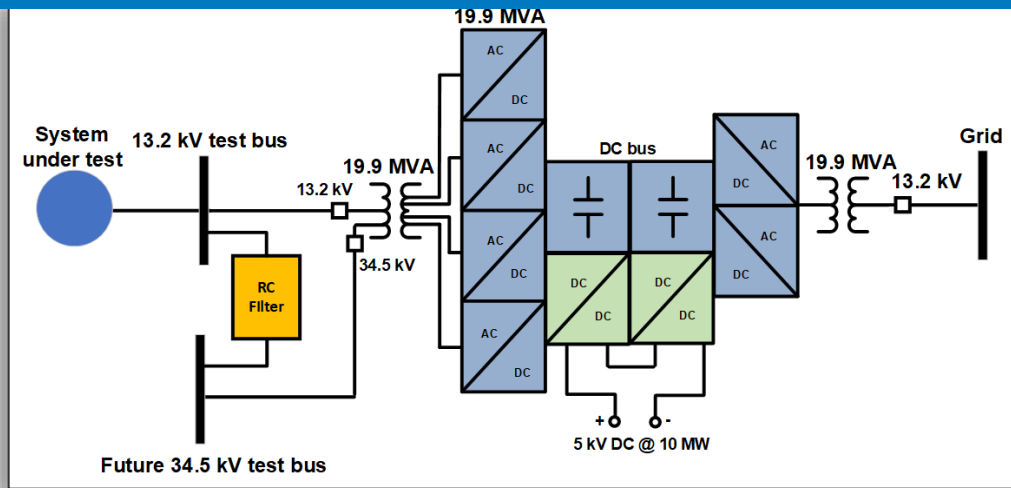

100 μ S response time

New features

- 5 kV MVDC grid simulator (PHIL capable)
- Voltage or current source operation
- Seamless transition between voltage and current source modes
- Emulation of full set of resiliency services:
 - Black start
 - Power system restoration schemes
 - Microgrids
- Flexible configurations are possible when combined with CGI#1:
 - Two independent experiments
 - Parallel operation
 - Back-to-back operation
 - Emulation of isolated, partially or fully grid-connected microgrids

Recent GFM Testing Projects

GFM PV Project (GE-NREL)

3-winding
transformer



- GFM controls validation testing complete with 2 MW DC supply (transient tests, impedance scans, black-start, islanded operation, etc.)
- LV5 inverter is connected to a real PV array at NREL
- GFM PV demonstration under real resource variability conditions

Type 3 GFM WTG project (GE-NREL)

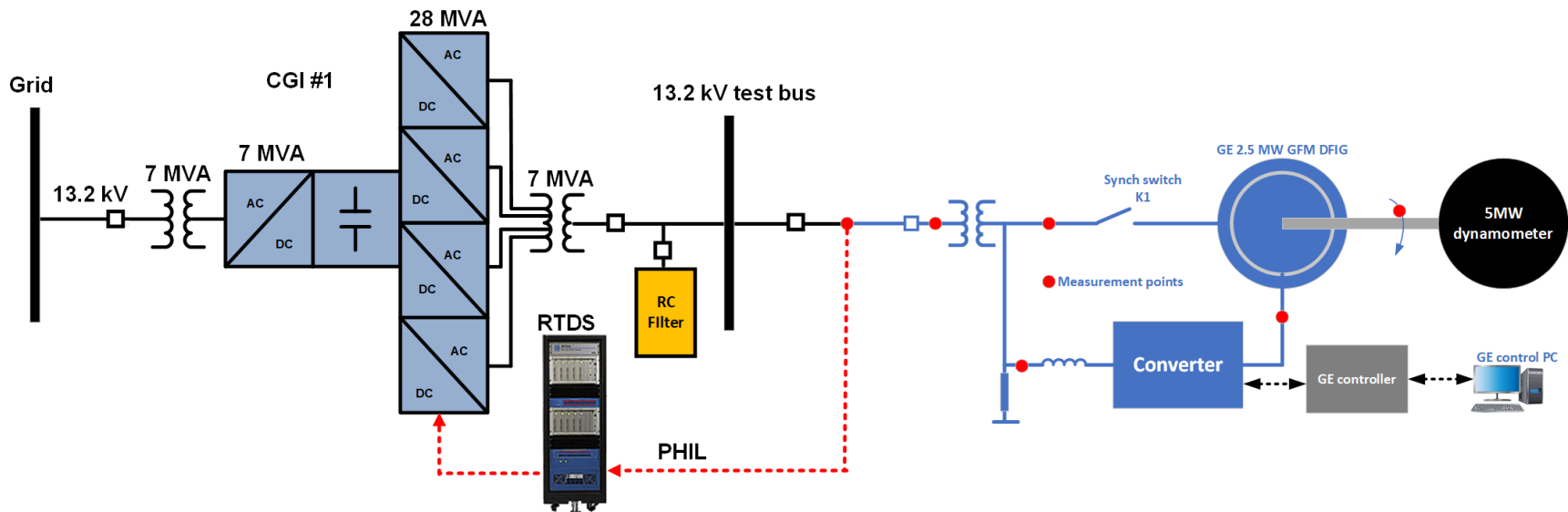

- Testing under controlled grid conditions:
 - Grid strength emulated by CGI power-hardware-in-the-loop
 - Balanced and unbalanced low-voltage ride-through (LVRT) and high-voltage ride-through (HVRT)
 - Frequency variations, phase jumps
 - Islanded operation.
 - RTDS and PSCAD model validation

Type 3 GFM Wind - 3-phase LVRT Test

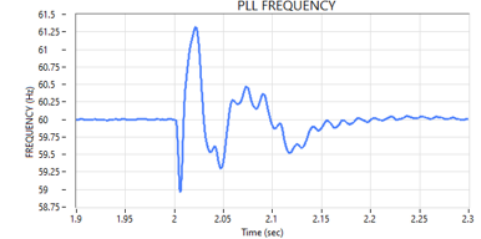
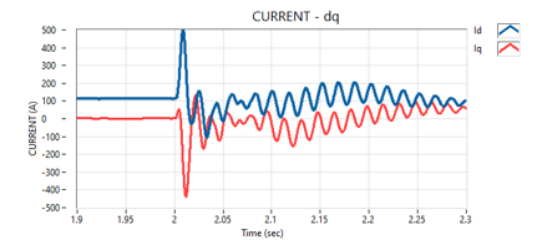
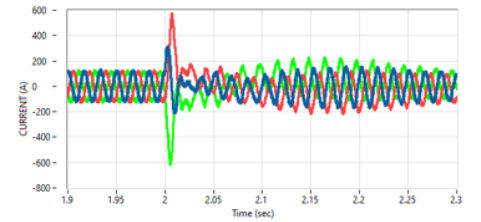
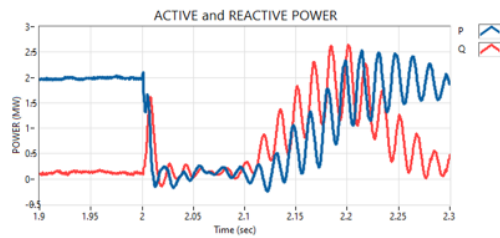
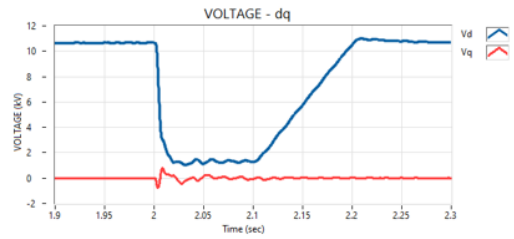
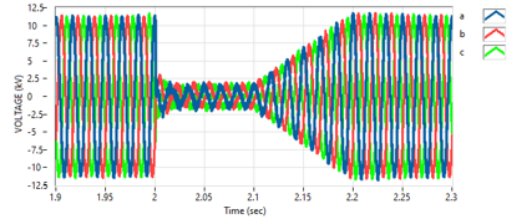
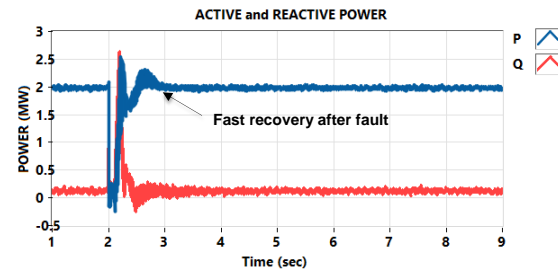
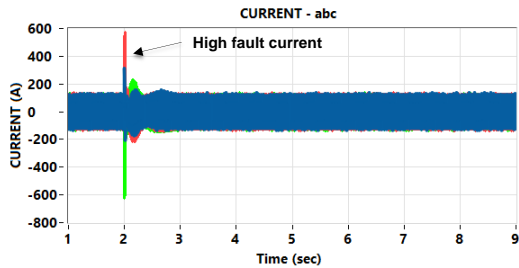
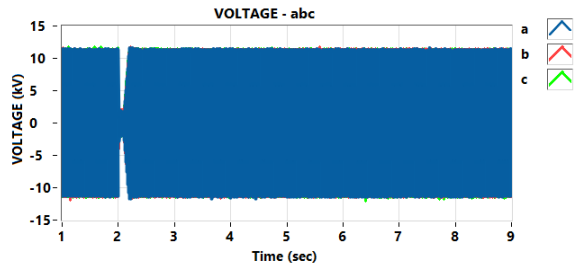

Wind-Only Microgrid Test

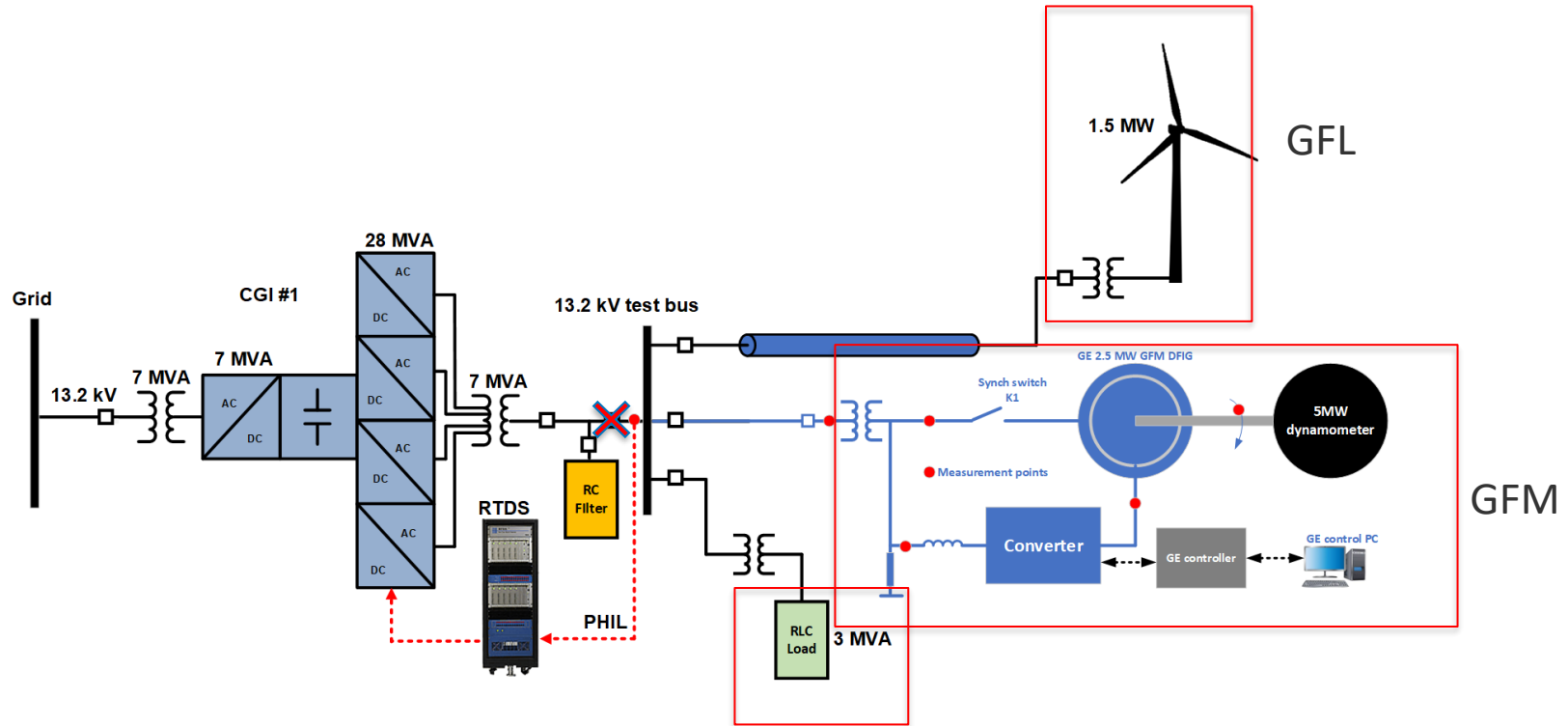

GFM GE 2.5 MW + GFL GE 1.5 MW + Load Bank Islanded Operation

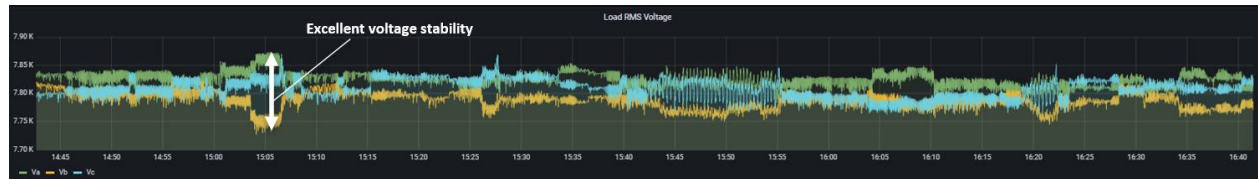

Quantifying System Needs from GFM Resources

19.5 Hz Oscillation Event in Kauai Island (Hawaii)

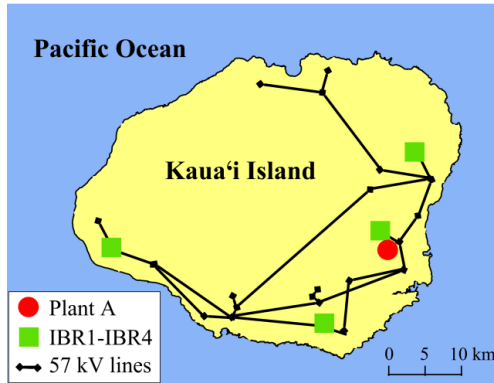
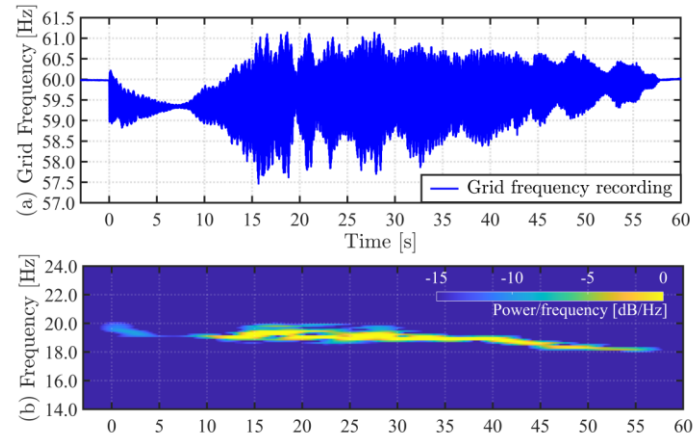

TABLE I
KIUC GENERATION MIX
BEFORE AND AFTER EVENT

Time	$t = 0^-$ s	$t = 60$ s
Plant A	60.6%	0.0% ↓
IBR1	4.1%	14.0% ↑
IBR2	4.6%	21.0% ↑
IBR3	0.0%	14.0% ↑
IBR4	4.1%	23.0% ↑
Biomass	13.7%	14.0% ↑
Hydros	13.0%	13.0% —



Source: S. Dong, et. al., "Analysis of November 21, 2021, Kaua'i Island Power System 18-20 Hz Oscillations" Link:

<https://arxiv.org/pdf/2301.05781.pdf>

- The oscillation event started after tripping of a large synchronous generator.
- **Problem:** Impedance-based stability analysis has showed the loss of grid strength to be the root-cause of oscillations.

IBR Operation in KIUC for Different Grid Strengths

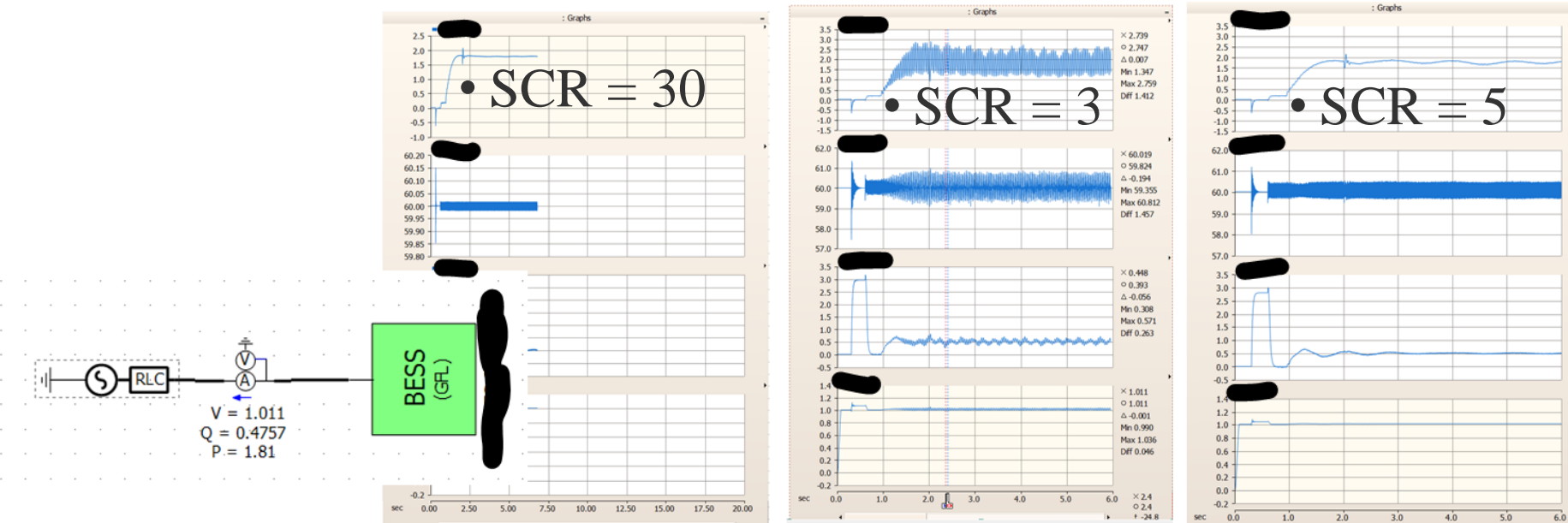

Solution: GFM resources should improve system strength to support stability of GFL IBRs in the region

Tests to Quantify Strength Improvement by GFM

- ☹ Can we look at SCR improvement? → NO, SCR is a steady-state metric, GFM is a dynamic (fast timescale) performance behavior.
- ☹ SCR is not a good indicator of grid strength.
- 😊 Impedance scan over a broad frequency range – quantify impedance reduction at frequencies of interest → V/I frequency scan.
- 😊 Grid voltage magnitude stiffness to reactive power loading → V/Q frequency scan or time-domain experiment.
- 😊 Grid voltage angle stiffness to active power loading → θ_v/P frequency scan or time-domain experiment.

Many of these tests can also be done in the field for GFM technology demonstration

Advanced Testing of GFM Resources

Voltage Source Behind a Reactor

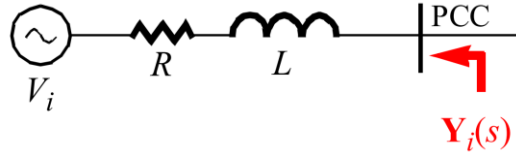

Time-Domain

- Reactive power (Q) output in response to 10% drop in grid voltage magnitude (V_m)

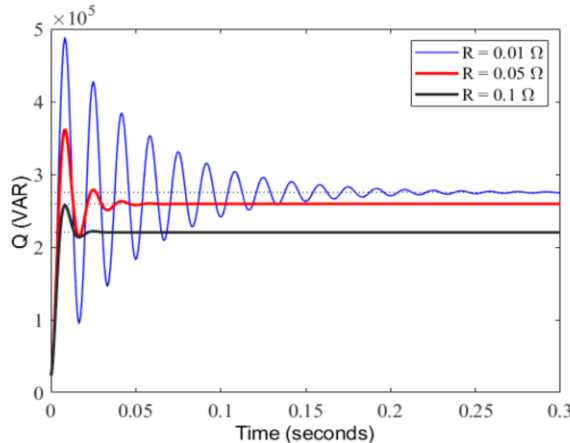

$$\left. \frac{Q(s)}{V_m(s)} \right|_{\theta(s)=0} = \frac{Q_0}{V_1} - \frac{3}{2} V_1 \cdot \frac{\omega_1 L}{(R + sL)^2 + (\omega_1 L)^2}$$

Ref.: S. Shah, et. al., "[A testing framework for grid-forming resources](#)," 2023 IEEE Power and Energy Society General Meeting, Orlando, FL.

Frequency-Domain

- Transfer function from V_m to Q

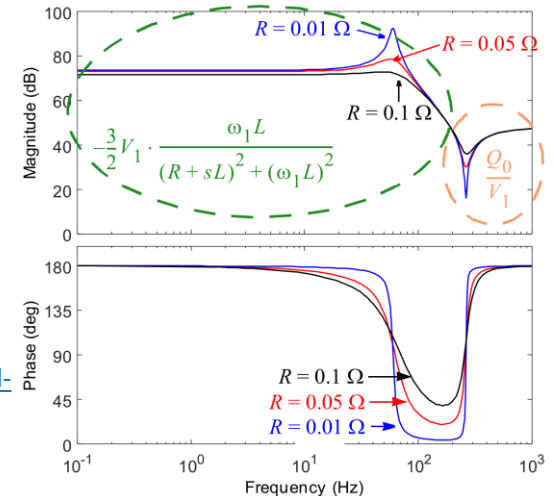

Pass-Fail Criteria Using Frequency Scan

- If in the Q/V frequency scan,
 - the magnitude/gain is constant/flat between 4 to 40 Hz, and
 - the phase is closer to 180 degrees between 4 to 40 Hz,
- Then the resource is a grid-forming resource
- Else, the resource is not a grid-forming resource

Frequency Scans (Q/V): Experiments at NREL

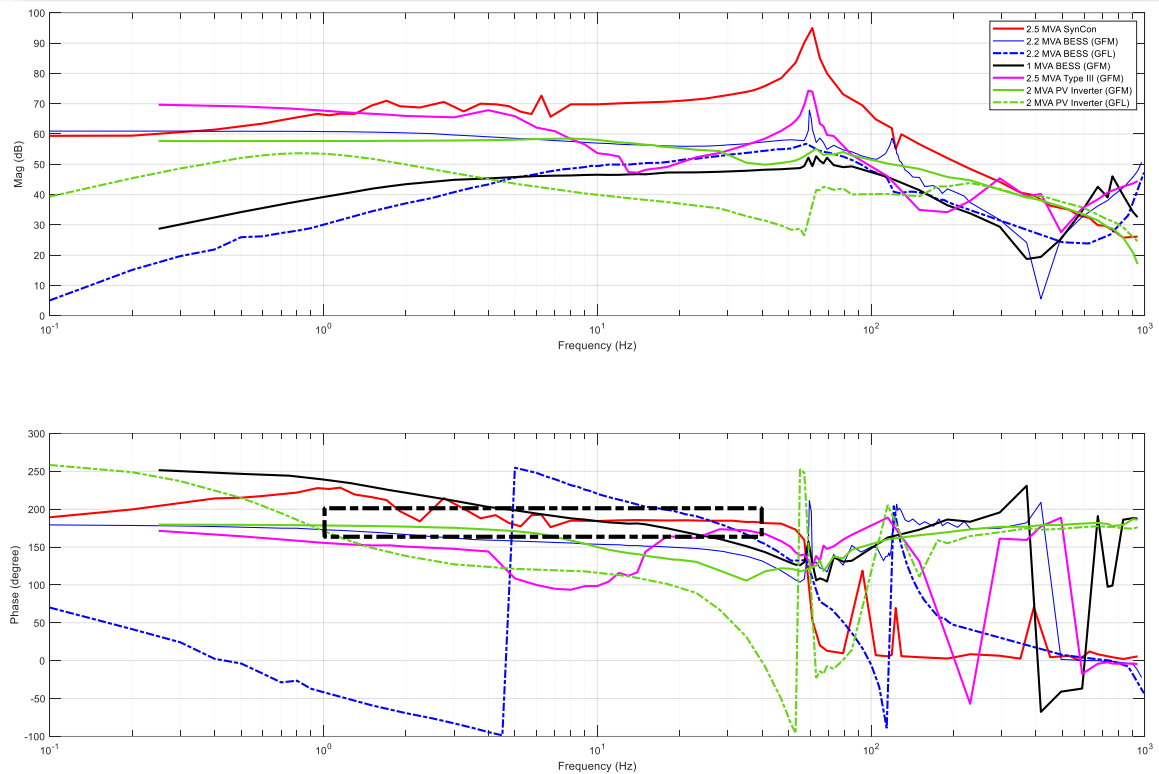

Grid: V/Q

GFM: Q/V

Loss of Last Synchronous Generator

BESS (1 MW/1 MWh)



Inverter can operate in both GFM and GFL modes

Test Sequence

- Open Breaker 1
- Open Breaker 2

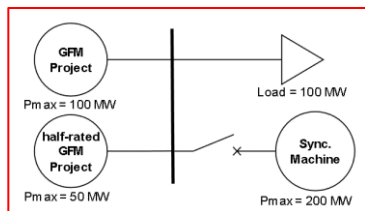

Source: Andrew Isaacs, Electronix

BRK 2



SynCon (2 MVA)



BRK 1



Load Bank
(3 MW/3 MVA)

Stability during Loss of Last Syn. Generator

Inverter in GFL Mode

Step Jump in Load

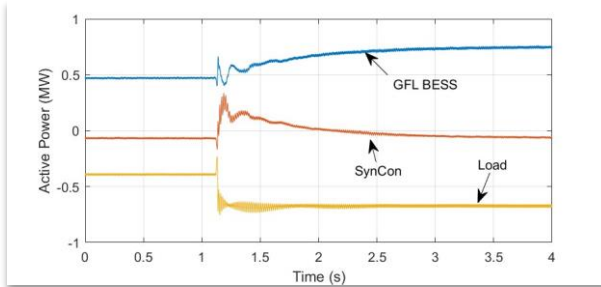

SynCon Tripped

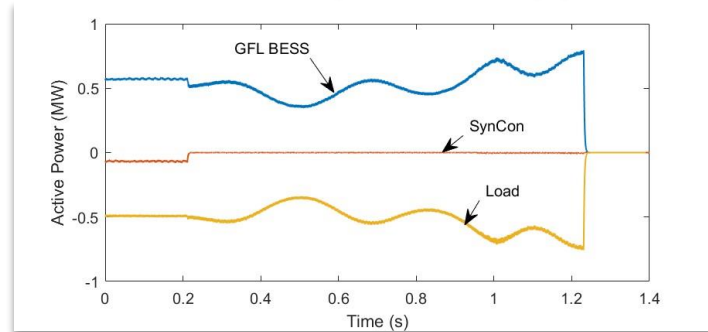

Inverter in GFM Mode

Loss of Grid

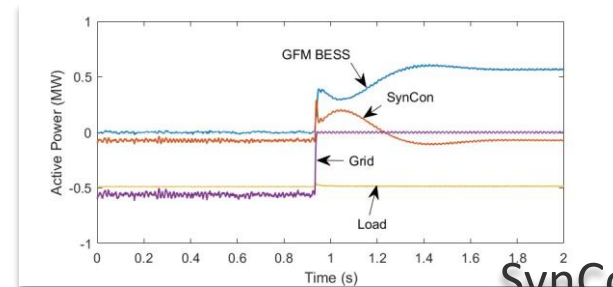

SynCon Tripped

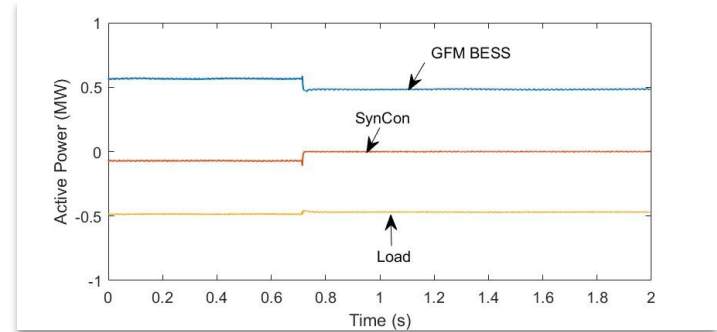

Need of a Reactor in Test Setup for GFM

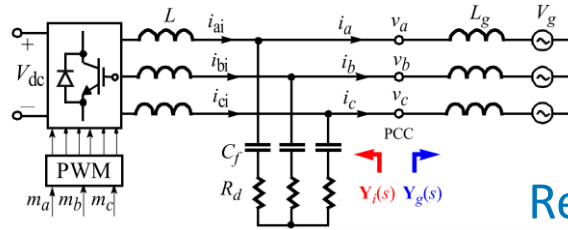

Response for Different L_g

Nyquist Plot of $\det.[Y_i(s) \cdot Y_g(s)^{-1}]$

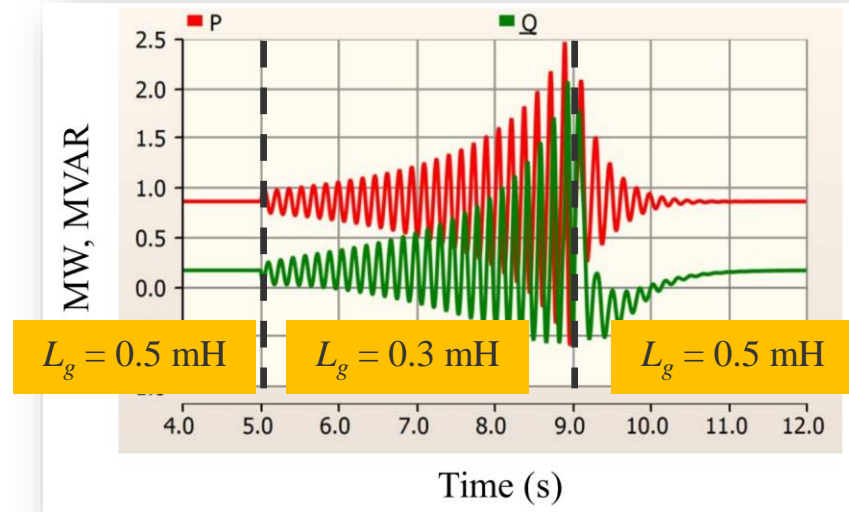
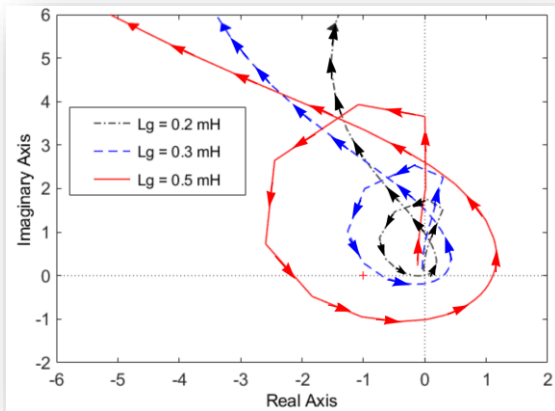

A New NREL Equipment Enables Weak Grid Testing



- Medium Voltage Impedance Network (MVIN)
 - Consist of reactors and capacitors
 - **Real emulation** of weak grid conditions down to short-circuit ratio (SCR) of 1 for up to 7 MVA test articles
 - **Real emulation** of 50% series compensation

Value of PHIL Testing

Hardware

Can be a single technology or combination of technologies



System Model

High value



Comparable capacities

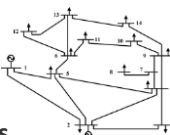

Lower value



The system is much bigger than hardware

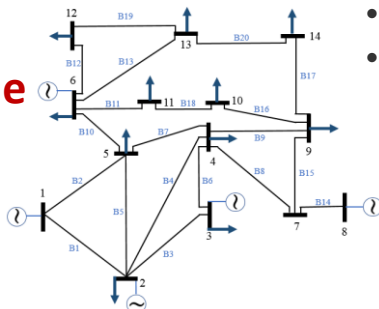

Low or no value



Hardware is extremely small compared to the system

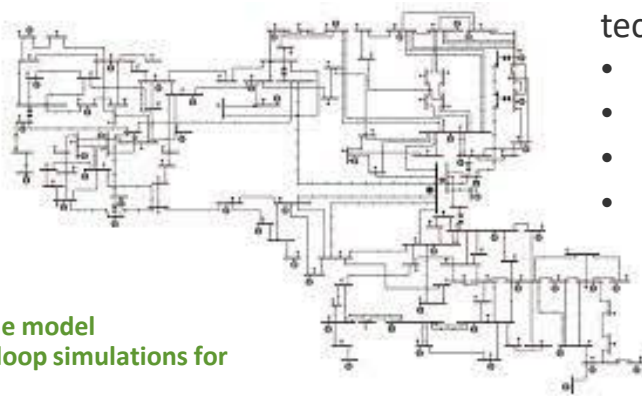

- Understand the impact of the grid on test article
- Understand the impact of test article on the grid
- Validate controls
- De-risk field deployment
- Accelerate time to market

Important: Ratio between capacities of test article and real-time model of the system it is connected to.

Important: How scalable is the technology under test?

- Wind
- Solar
- Storage
- Hybrid

Source: Vahan Gevorgian

1. Conduct open-loop testing to fully validate the model
2. Then perform non-real time software-in-the-loop simulations for large power systems

Summary

- Improvement of grid strength is the core system need from GFM resources
 - Methods are available to translate this need to quantifiable GFM performance specifications
 - Advanced tests can check if a GFM resource meets performance specifications
 - Laboratory and field tests can demonstrate stabilizing impact of GFM



W. Slocum, NREL

Thank you!

www.nrel.gov

Shahil.Shah@nrel.gov

This work was authored by Alliance for Sustainable Energy, LLC, the manager and operator of the National Renewable Energy Laboratory for the U.S. Department of Energy (DOE) under Contract No. DE-AC36-08GO28308. Funding provided by U.S. Department of Energy Office of Energy Efficiency and Renewable Energy Wind Energy Technologies Office. The views expressed in the article do not necessarily represent the views of the DOE or the U.S. Government. The U.S. Government retains and the publisher, by accepting the article for publication, acknowledges that the U.S. Government retains a nonexclusive, paid-up, irrevocable, worldwide license to publish or reproduce the published form of this work, or allow others to do so, for U.S. Government purposes.

