



Mitigating Stability Issues with Offshore Wind

Xiaodong Liu

Transmission System Planning, Eversource Energy

Oct 21, 2024



Eversource's Offshore Wind Experience

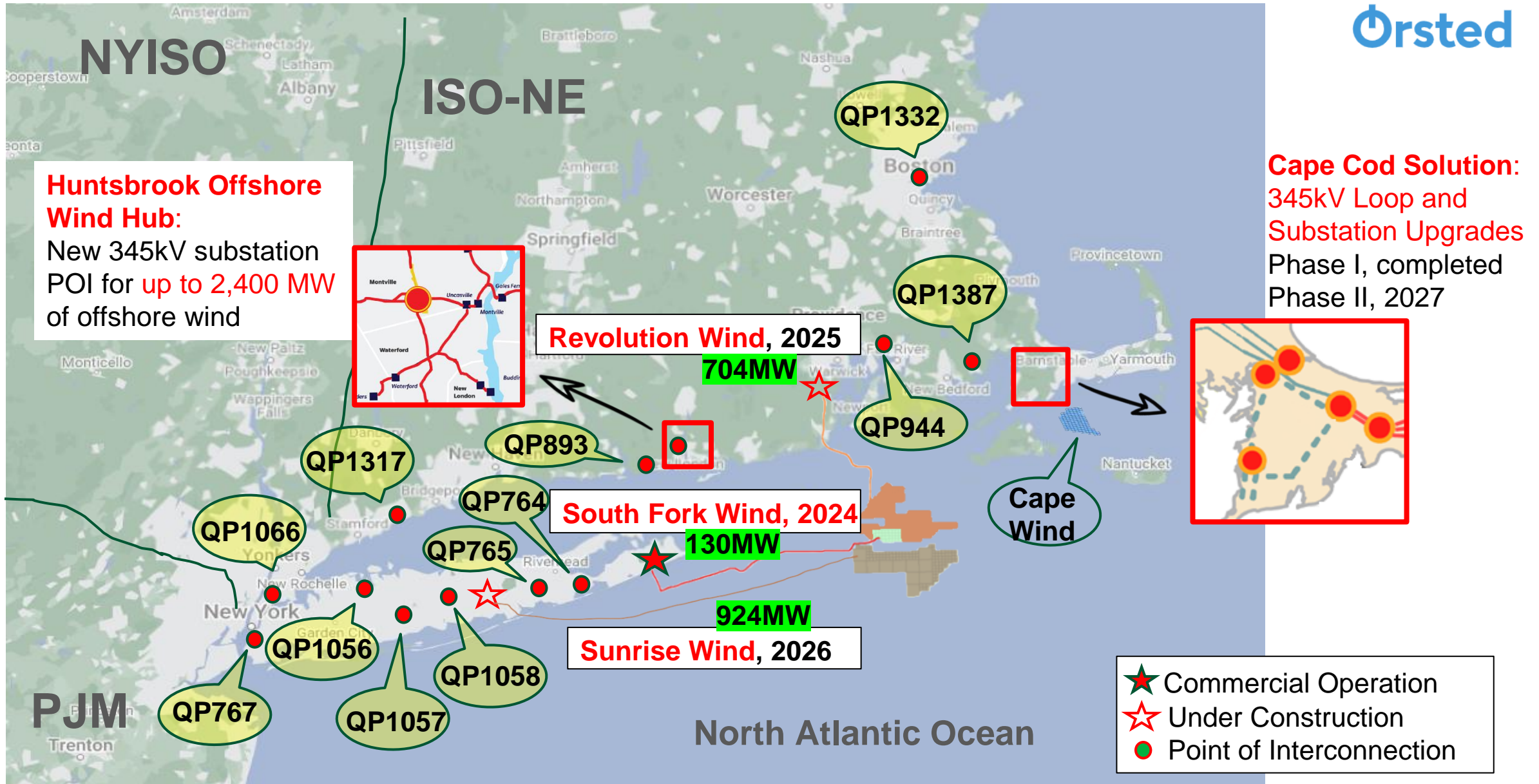

Definition and Classification of Stability

Power System Stability *

* Source: IEEE PES-TR77, 2020

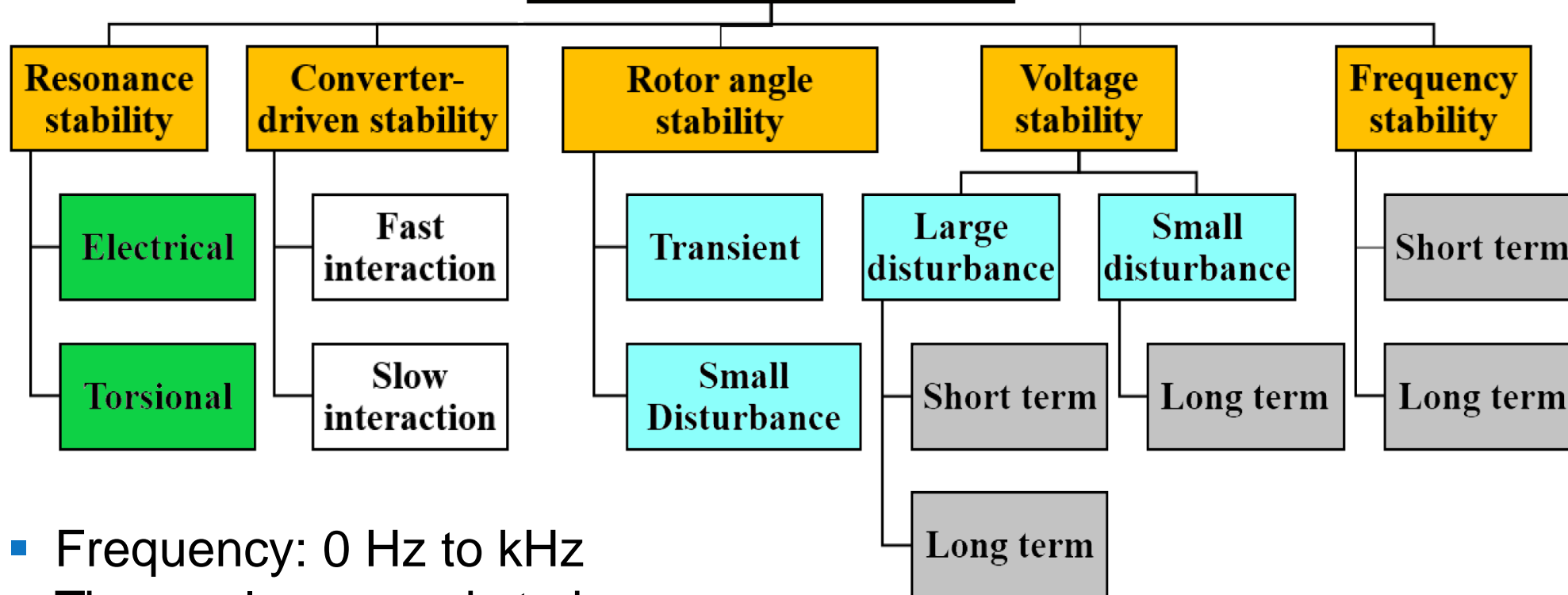

- Frequency: 0 Hz to kHz
- Timescale: seconds to hours
- Impact area: local to the entire system
- Hard to pinpoint the root cause
- Observed stability events triggered by IBRs around the world

Planning Study – Tools, Models and Procedure

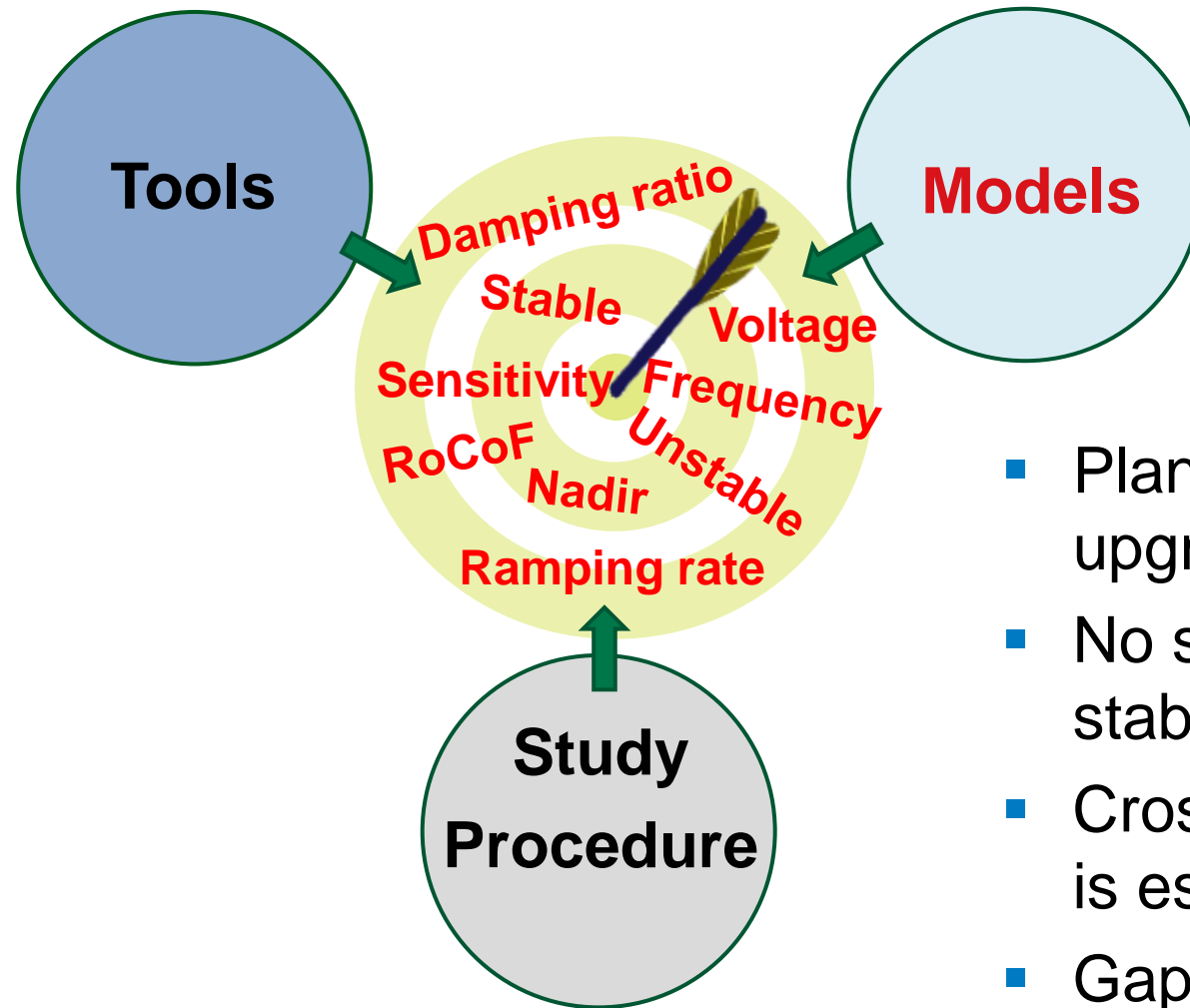

- Planning study identifies grid upgrades or improved controls
- No single tool or model fits every stability study
- Cross-validating results for credibility is essential
- Gaps still exist between the planning and actual operations

Emerging Technology - Grid Forming

- Essential for addressing low inertia and grid strength issues
- Enhanced frequency & RoCoF regulations
 - FFR
 - Possible large inherent inertia (e.g. E_STATCOM)
- Flexible controls to improve FRT performance and mitigate unstable oscillations

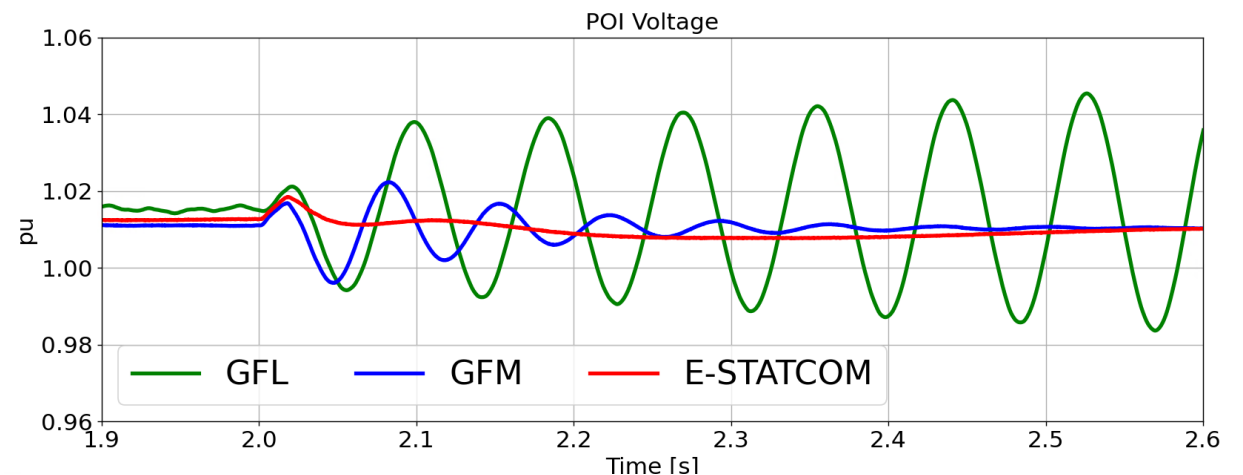

Standard, Standard, Standard



- Continued updates are necessary to meet new technical challenges (e.g. modeling)
- Flexible to incorporate emerging technology capabilities:
 - Performance-based Inertia definition
 - FFR
 - Black-start capability
 - Additional capabilities (unbalanced operation, short-circuit contribution..)

Integration Study Transparency

- Limited visibility of models impacts study outcomes.
- Enhanced collaboration and transparency between Transmission Planners and Developers are critical to streamline interconnection studies:
 - Achieve coordinate control strategies and robust, optimized system performance
 - Accelerate Interconnection Request study process

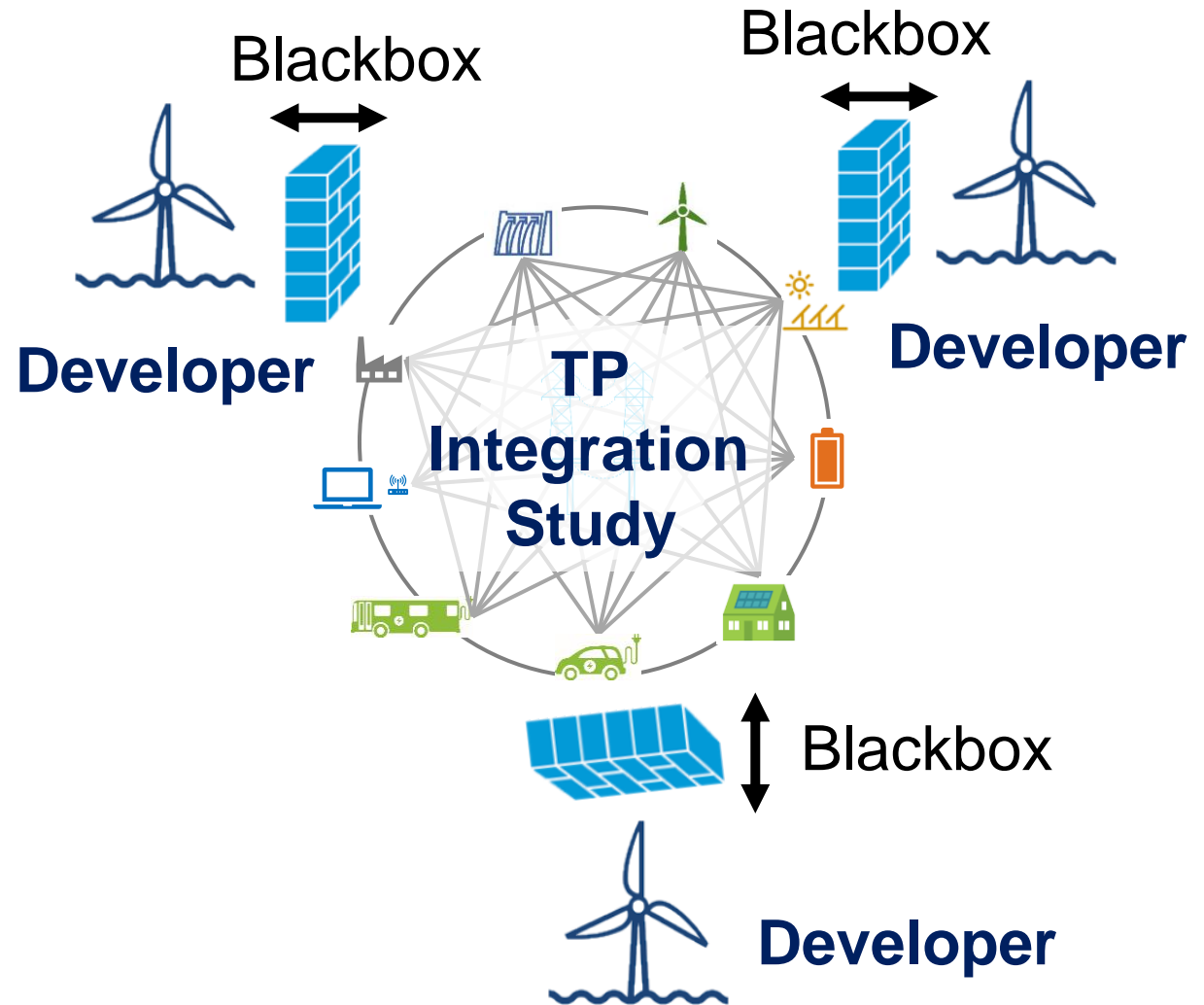

Operational Countermeasures

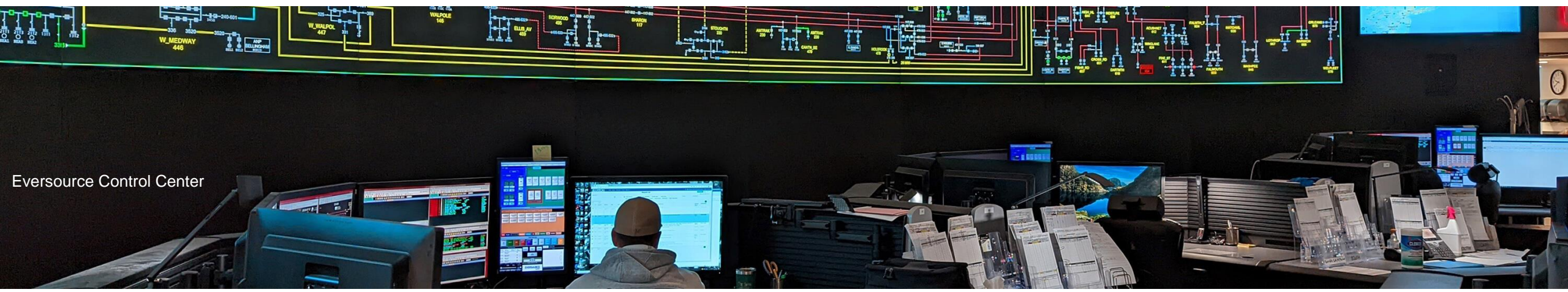

Eversource Control Center

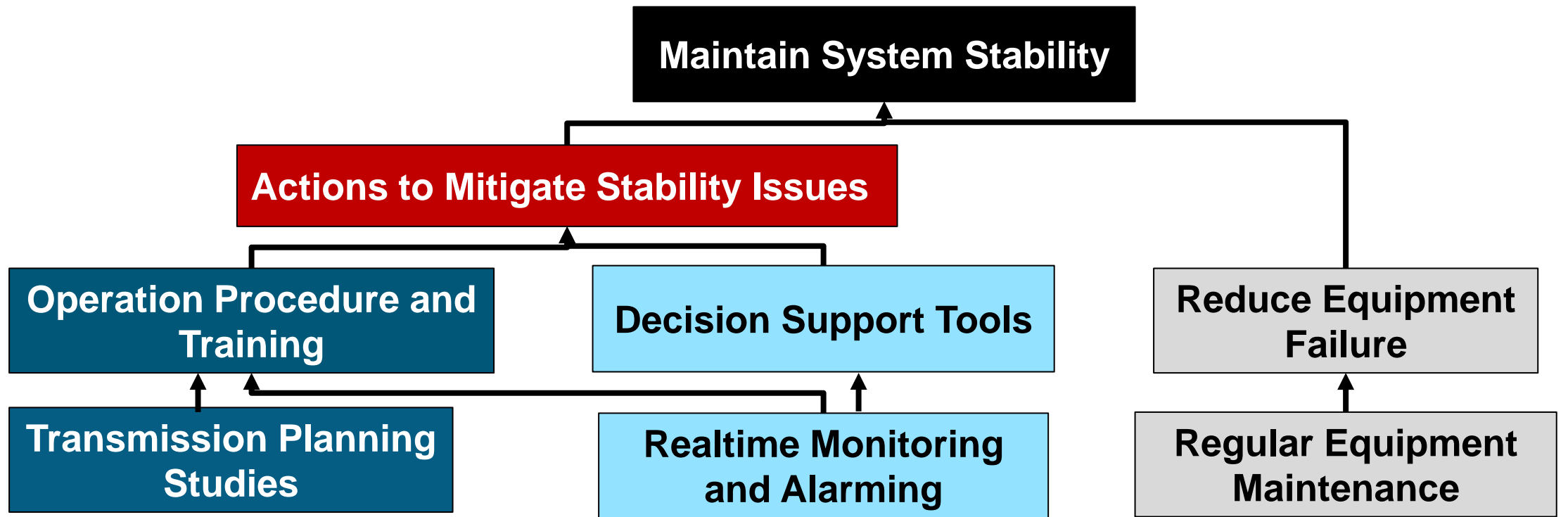

Protection & Control Countermeasures

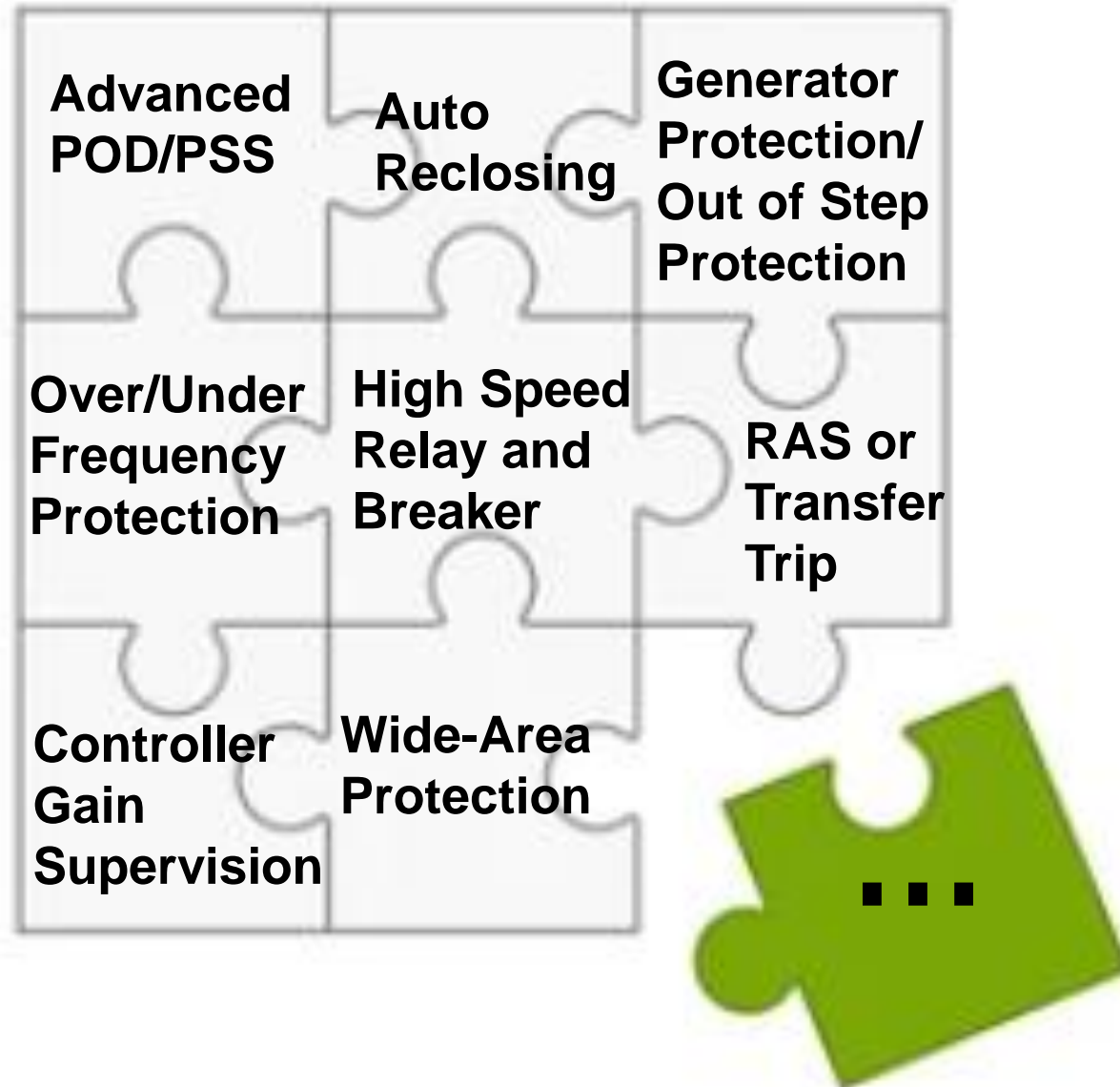

- Improved coordination and oscillation monitoring are critical to ensure
 - Fault isolation
 - System wide protection
 - Wide range of frequency event detection and protection
 - Appropriate corrective actions for small, large and uncontrolled oscillations

What's the Next?

Murphy's Law - "Anything that can go wrong will go wrong."

- Brainstorm all possibilities
- Develop and test contingency plans
- Learn and improve from events

