



Protection of Inverter-dominated Transmission Systems Evaluation for Hawai'i Island

Ulrich Muenz, Abhishek Banerjee, Suat Gumussoy, Siddharth Bhela, Swen Elpelt, Patrick Eisen, **Siemens Technology**

Evangelos Farantatos, Aboutaleb Haddadi, Tapas Barik, Shuvangkar Das, Deepak Ramasubramanian, **EPRI**

Matthew Reno, Daniel Kelly, **Sandia National Laboratory**

Aditya Ashok, Zerui Dong, **OPAL-RT Technologies**

In collaboration with **Hawaiian Electric, Manitoba Hydro International, Electranix**

The information, data, or work presented herein was funded in part by the **Advanced Research Projects Agency-Energy (ARPA-E), U.S. Department of Energy**, under Award Number DE-AR0001570. The views and opinions of authors expressed herein do not necessarily state or reflect those of the United States Government or any agency thereof.

Operator challenges with high renewable integration

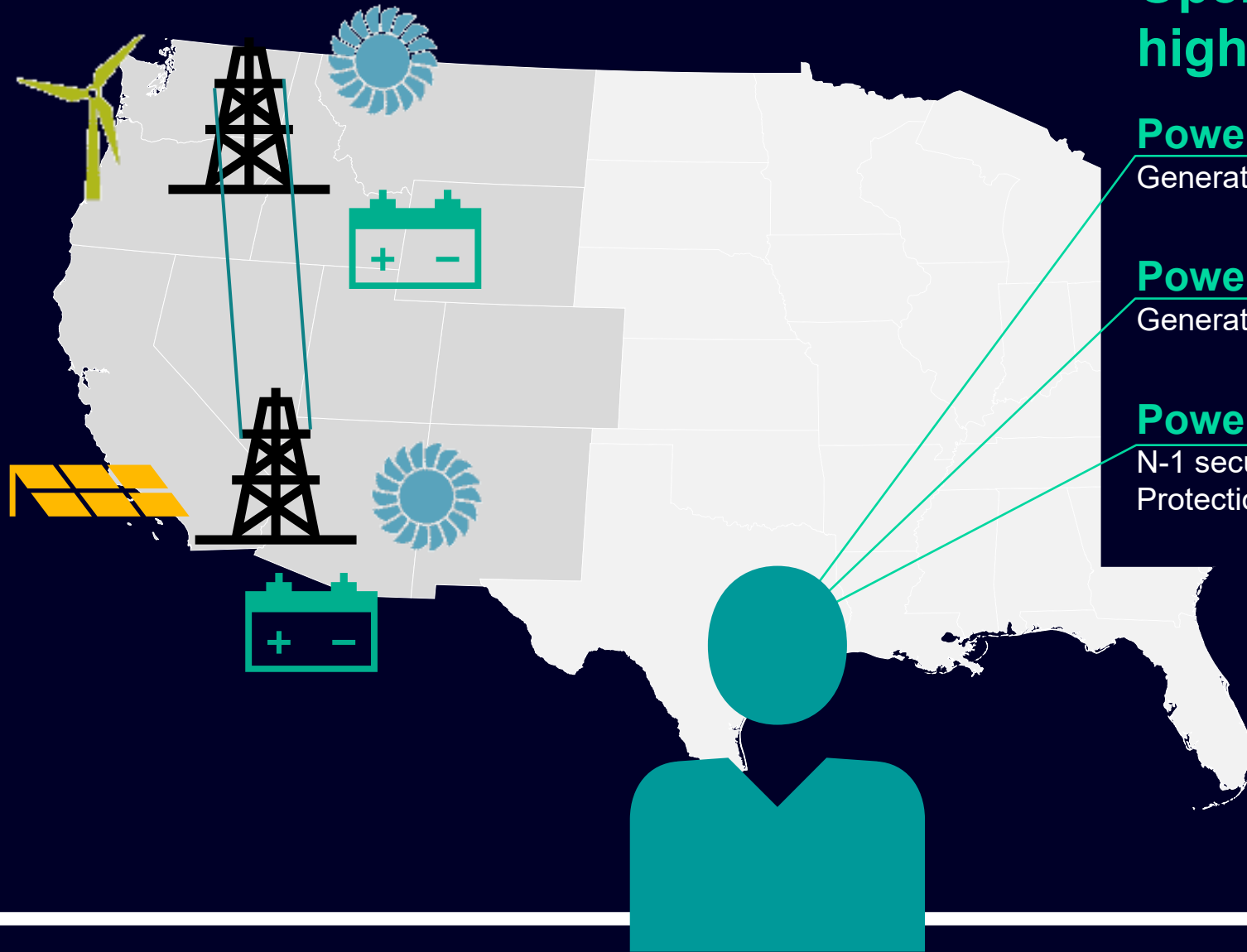

Power Balance

Generation meets load

Power Transfer

Generation far from load

Power System Stability

N-1 security

Protection

Focus today

Agenda & Key Messages from our evaluation for Hawai'i Island

1

**Fault-Ride Through functions successfully limit
Grid-forming Inverter currents**

2

**POTT and LCD protection schemes clear faults in
inverter-dominated transmission systems in 100ms**

3

**Co-simulation of high-fidelity IBR & relay models
supports protection analysis in IBR-dominated systems**

4

**Protection-inverter co-design reveals need for good
configurations to avoid expensive all-LCD schemes**

Fault-ride through (FRT) functions for grid-forming (GFM) inverters are fundamentally different from FRT functions for grid-following (GFL) inverters

FRT in **grid-following IBRs** respond **slowly** to **voltage dip** to implement P&Q priority of fault currents following IEEE 2800/1547

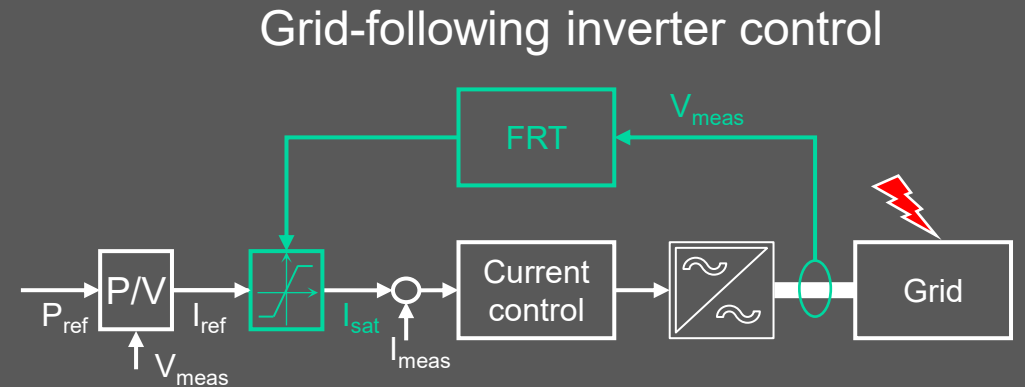
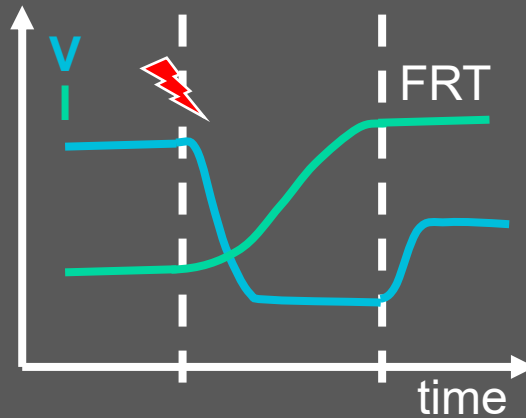

FRT in **grid-forming IBRs** respond **fast** to **current surge** to avoid HW damage while operating close to GFM behavior

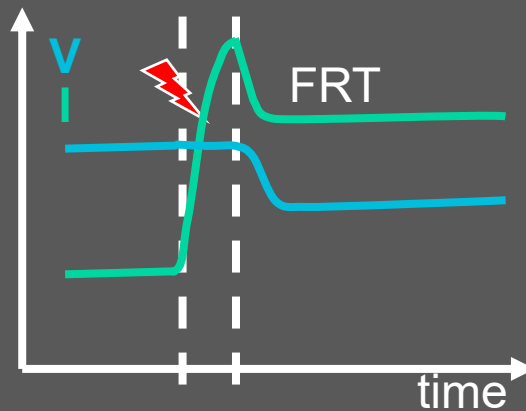

Grid-forming inverter control

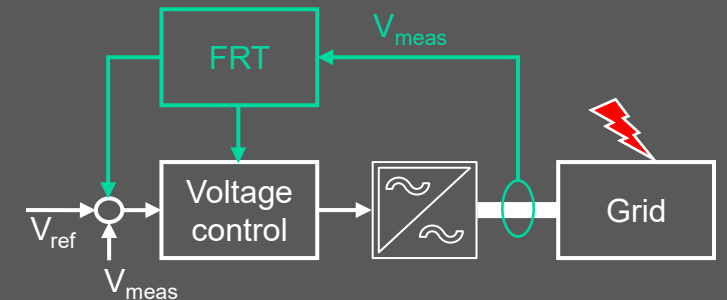

We compare different Fault-Ride Through (FRT) functions for Grid-forming (GFM) inverters

	Current limit	Virtual impedance
<p>Cascaded Control (CC)</p> <p>Virtual impedance (VI) Current limit (CL)</p>	<p>CC-CL</p> <p>+</p>	<p>-</p>
<p>CC-VI</p>	<p>-</p>	<p>+</p>
<p>CC-CL-VI</p>	<p>+</p>	<p>+</p>
<p>Direct Voltage Control (DVC)</p> <p>Virtual impedance (VI)</p>	<p>DVC-VI</p> <p>-</p>	<p>+</p>

We evaluate FRT functions in an EMT model of Hawai'i Island

Hawai'i Island model

- Converted from HECO's PSS/E model
- 100% IBR generation mix with
 - 4 GFM batteries
 - 1 GFL wind turbine
- 90MW load across all buses
- Mid- and end-line faults in fault location 1

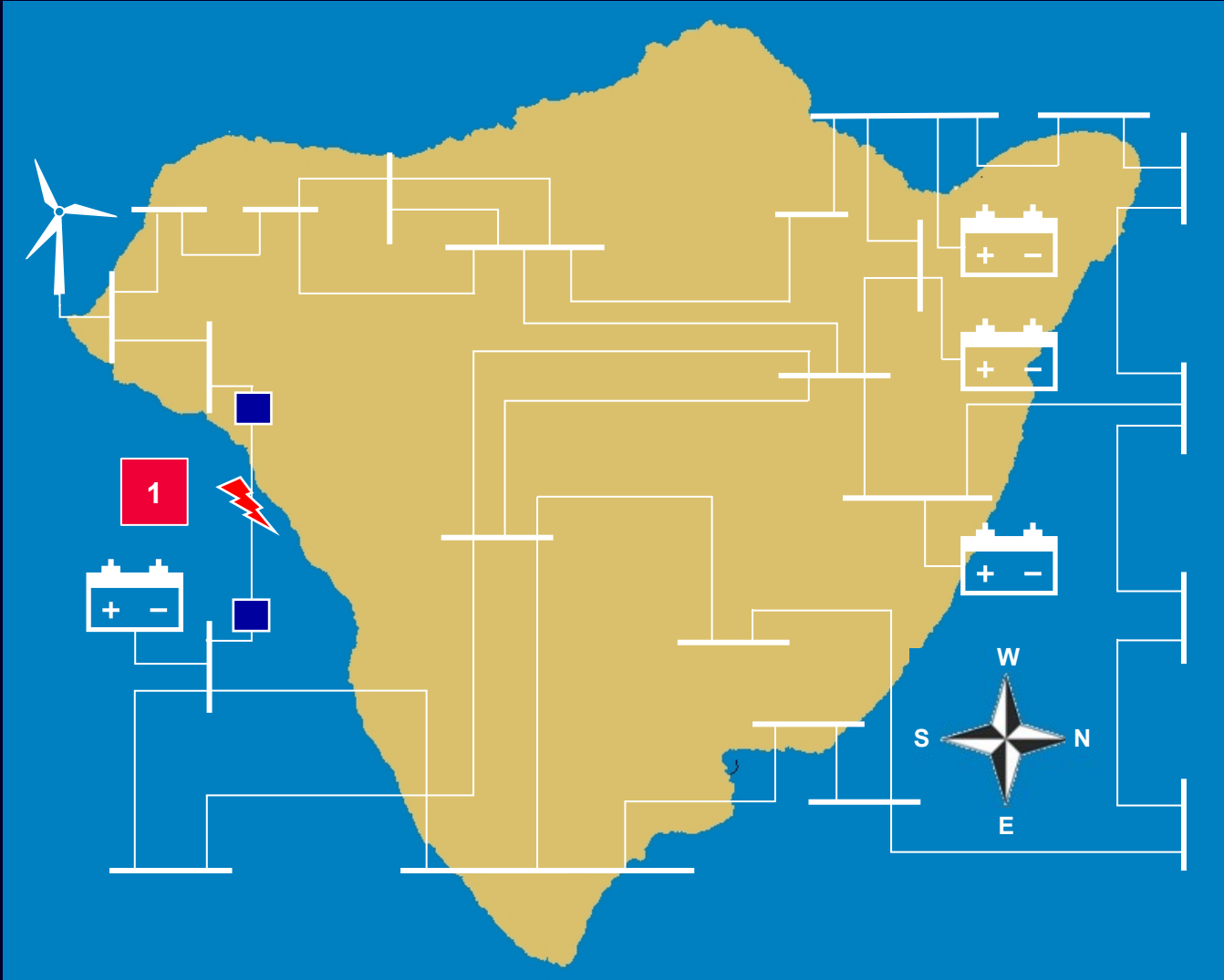
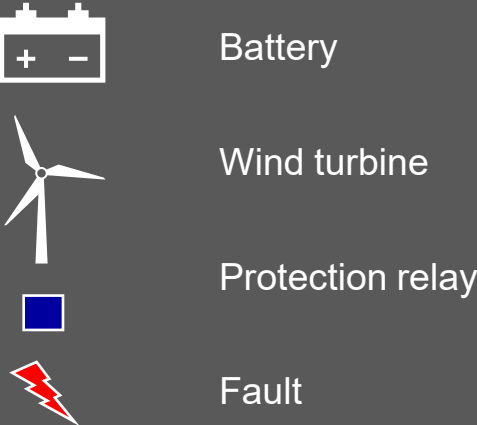

All 4 FRT functions successfully limit IBR currents during balanced and unbalanced faults and show comparable voltage and current dynamics

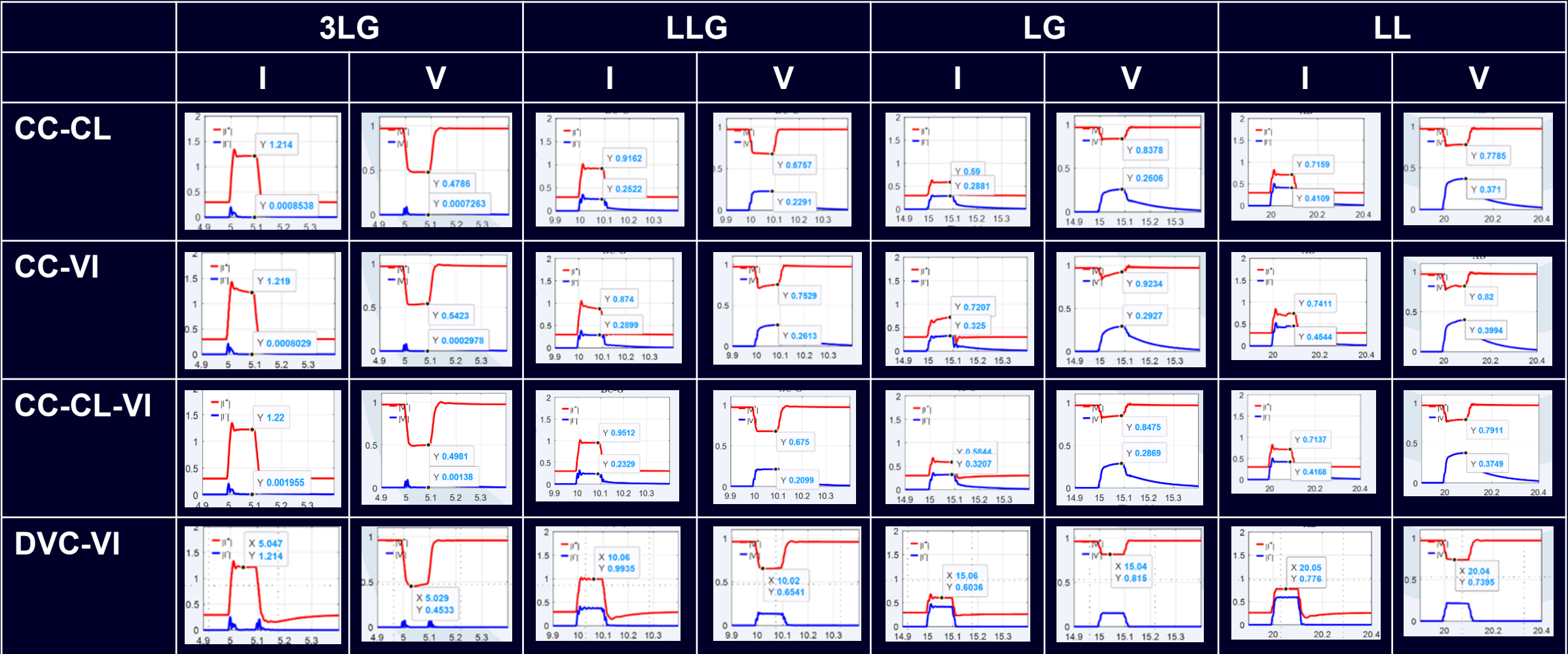

Red: positive sequence; blue: negative sequence

Agenda & Key Messages from our evaluation for Hawai'i Island

1

Fault-Ride Through functions successfully limit Grid-forming Inverter currents

2

POTT and LCD protection schemes clear faults in inverter-dominated transmission systems in 100ms

3

Co-simulation of high-fidelity IBR & relay models supports protection analysis in IBR-dominated systems

4

Protection-inverter co-design reveals need for good configurations to avoid expensive all-LCD schemes

We are evaluating different FRT and protection functions in a Protection Hardware-in-the-Loop (PHIL) testbed with commercial Siprotec relays and 4 different faults types

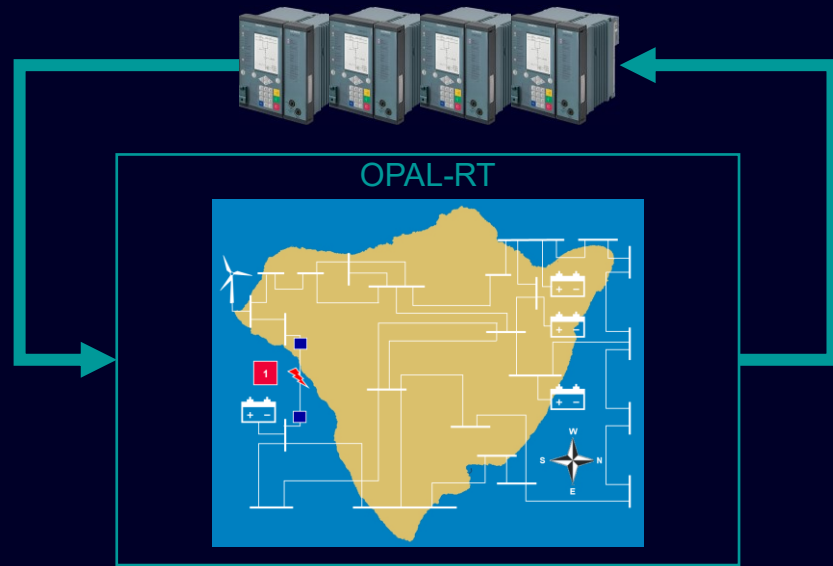

Fault-Ride Through

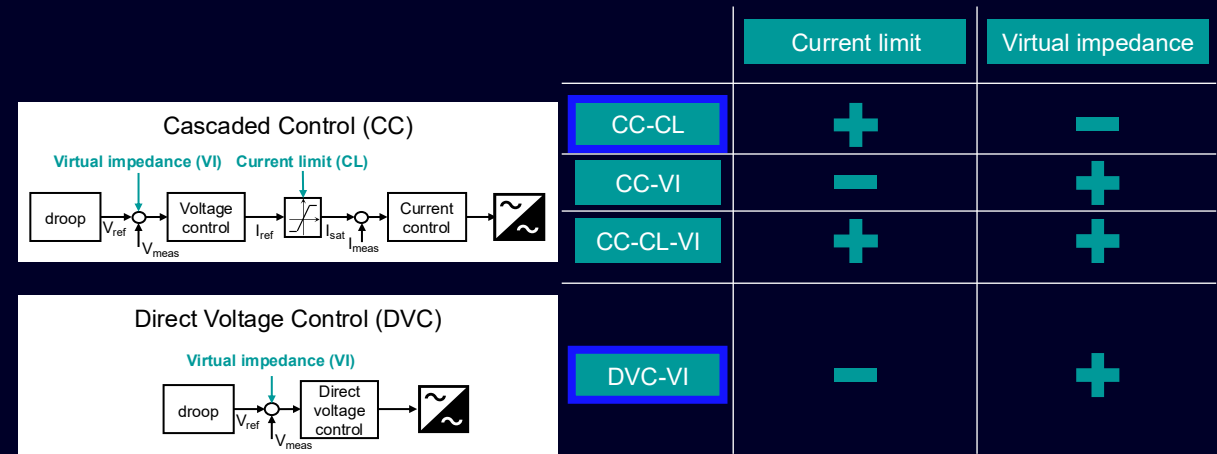

Faults (mid-line, end-line)

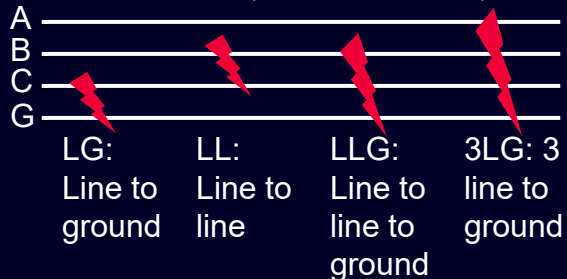

Protection

Distance (Z)
POTT
Differential (LCD)

Fault clearing times [ms] for balanced & unbalanced faults

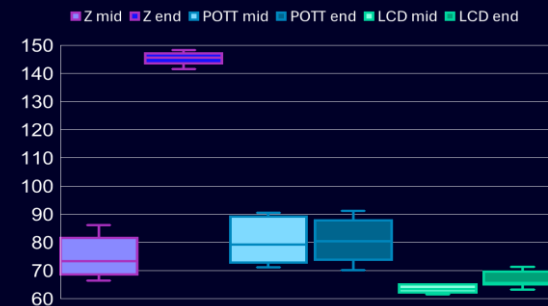

State-of-the-Art LCD and POTT protection functions clear balanced and unbalanced faults for CC-CL and DVC-VI FRT functions in less than 6 cycles

Fault-clearing time evaluation

Evaluation for 48 scenarios:

- CC-CL & DVC-VI FRT functions
- Distance, POTT, and LCD protection
- 3LG, LLG, LG, LL faults
- Mid-line & end-line at location 1
- Includes 50ms breaker opening delay

Conclusion

- LCD clears fastest
- POTT shows good performance
- Distance (Z) takes almost 150ms to clear end-line faults

Fault clearing times [ms] for balanced & unbalanced faults

■ Z mid ■ Z end ■ POTT mid ■ POTT end ■ LCD mid ■ LCD end

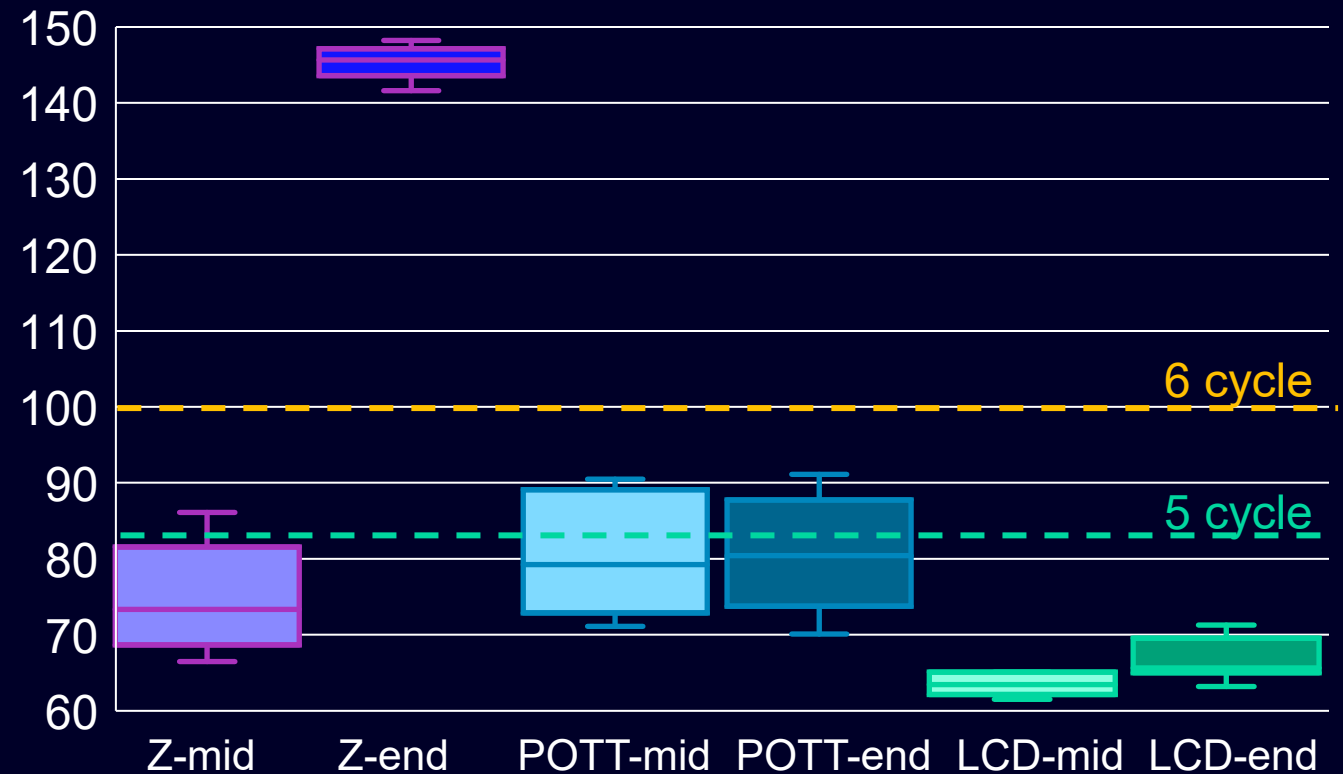

Agenda & Key Messages from our evaluation for Hawai'i Island

1

Fault-Ride Through functions successfully limit Grid-forming Inverter currents

2

POTT and LCD protection schemes clear faults in inverter-dominated transmission systems in 100ms

3

Co-simulation of high-fidelity IBR & relay models supports protection analysis in IBR-dominated systems

4

Protection-inverter co-design reveals need for good configurations to avoid expensive all-LCD schemes

We developed a prototype for a co-simulation between high-fidelity EMT simulations in PSCAD and high-fidelity relay simulations in Gridscale X APA (PSS/CAPE)

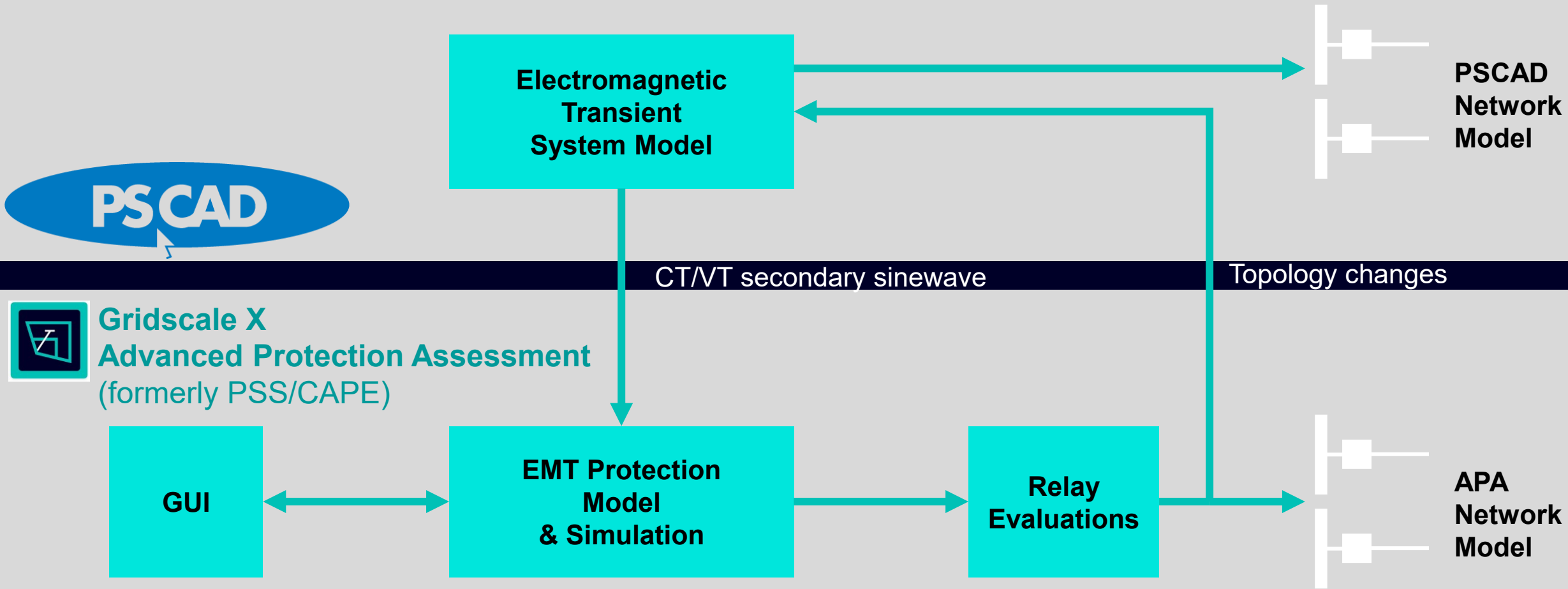

Co-simulation replicates accurately response of commercial relays in the PHIL testbed

Co-simulation accuracy evaluation

Evaluation for 48 scenarios for DVC-VI:

- Distance (zone 1, 2, 3), POTT, and LCD (fast, standard) protection
- 3LG, LLG, LG, LL mid-line faults
- 2 relays at location 1

Conclusion

- All mismatches below 1 cycle (16.6ms)
- LCD with lowest mismatch

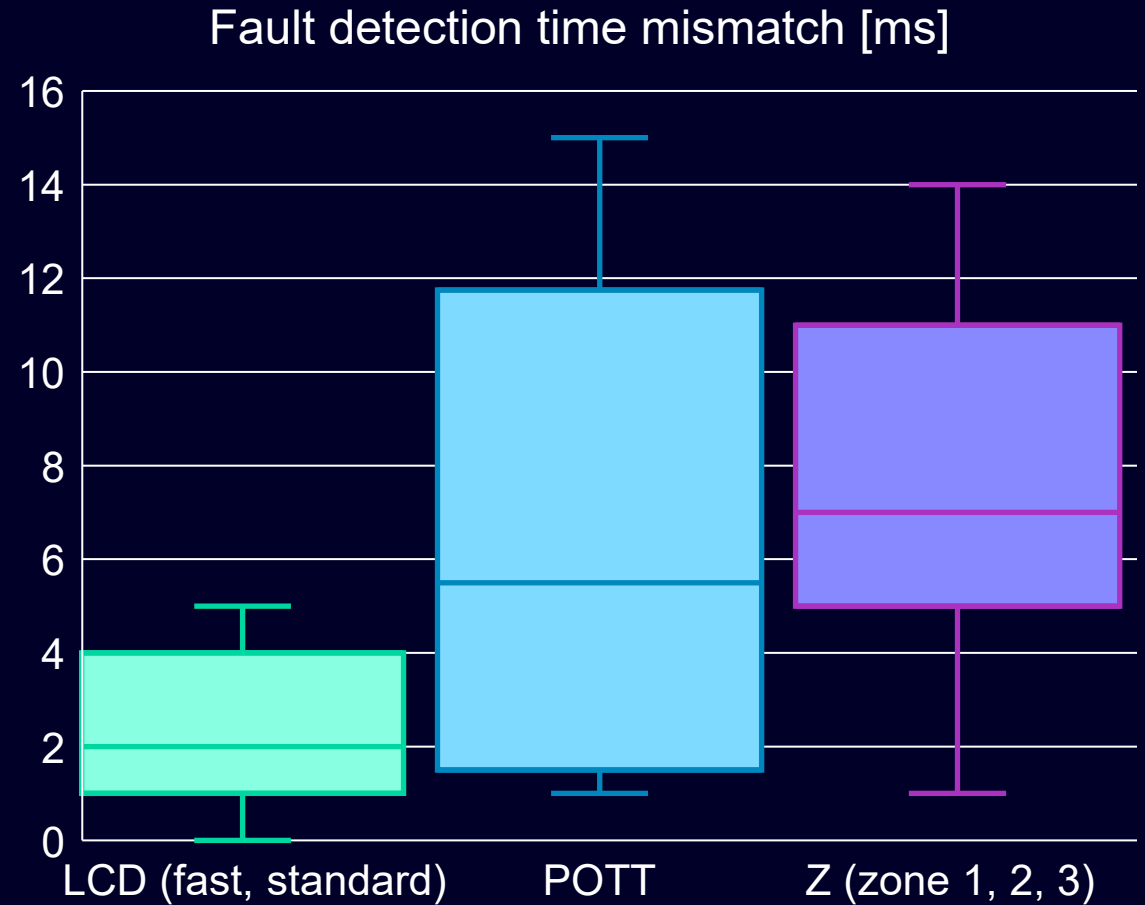

Agenda & Key Messages from our evaluation for Hawai'i Island

1

Fault-Ride Through functions successfully limit Grid-forming Inverter currents

2

POTT and LCD protection schemes clear faults in inverter-dominated transmission systems in 100ms

3

Co-simulation of high-fidelity IBR & relay models supports protection analysis in IBR-dominated systems

4

Protection-inverter co-design reveals need for good configurations to avoid expensive all-LCD schemes

Protection-Inverter Co-Design tool finds best FRT and relay configuration guided by 11 KPIs

Solution Architecture

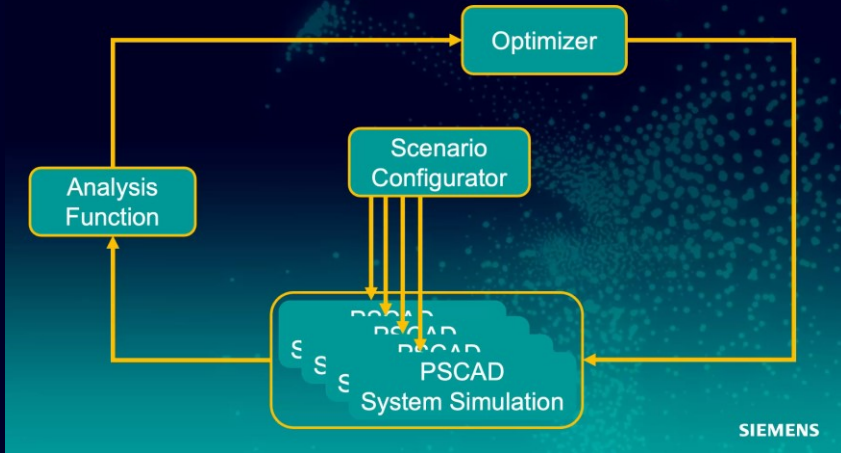

Rewards and Settings

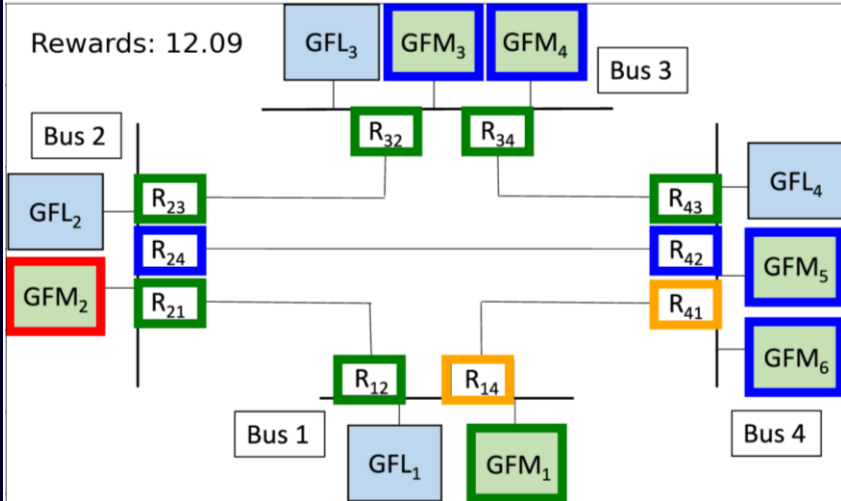

Optimization for Inverter and Protection Functions

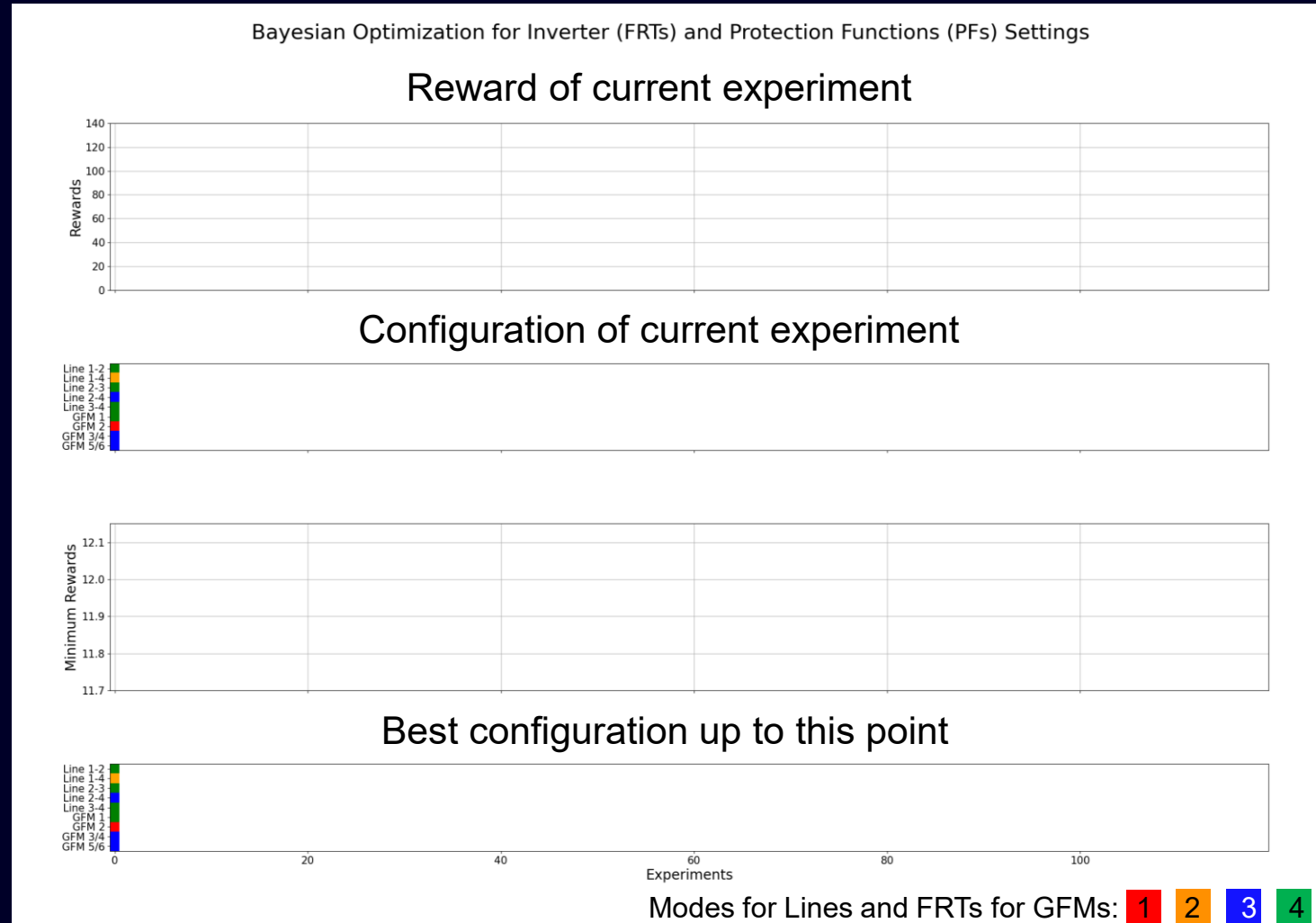

Comparison of 160 optimized designs reveals that all-LCD protection schemes provide best performance while less expensive schemes can achieve similar performance with optimized configuration

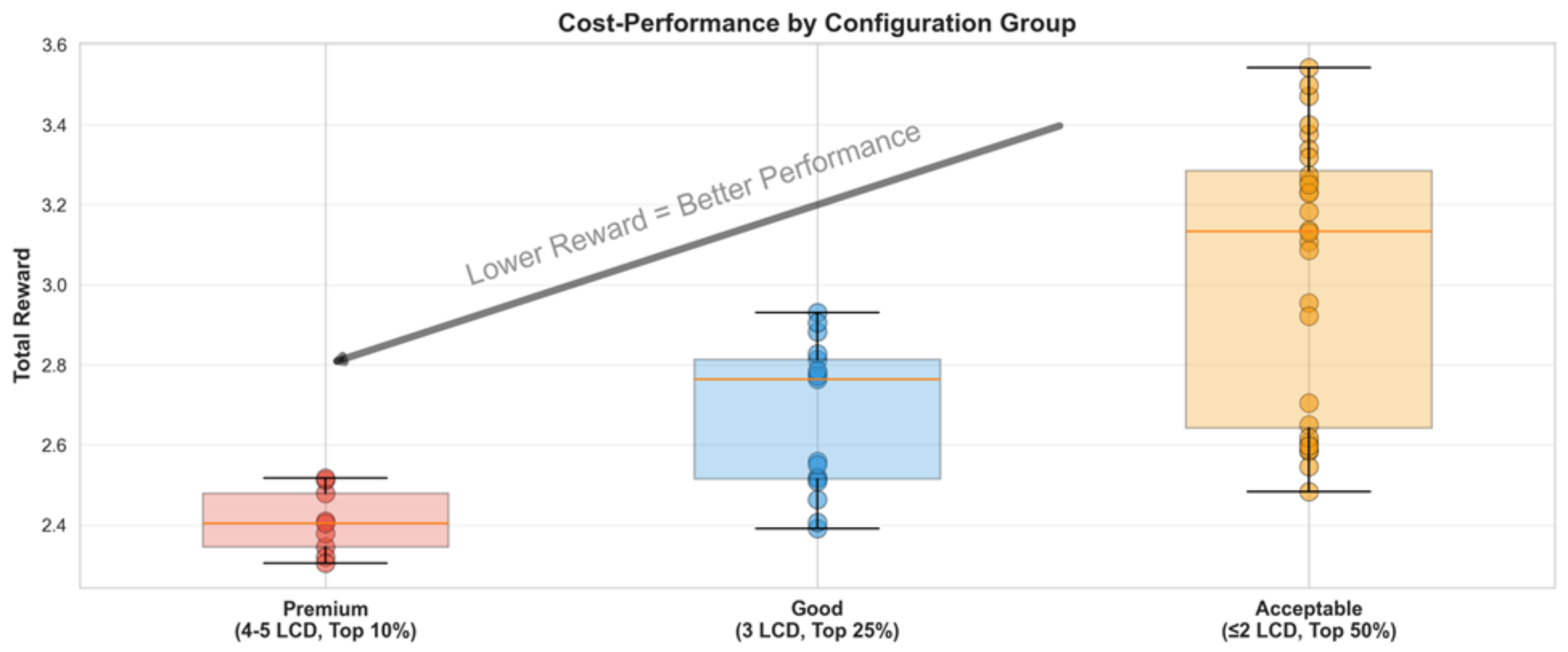

Big thank you to all collaborators!



Dr. Ulrich Muenz
Principal Investigator



Patrick Eisen
Project Manager

Siemens Research & Pre-development	Electric Power Research Institute	Sandia National Laboratories	Siemens CAPE & Siprotec	Manitoba Hydro International	OPAL-RT	Electranix	Hawaiian Electric
 <p>Dr. Siddharth Bhela Power system protection & PICO design tool</p>	 <p>Dr. Evangelos Farantatos IBR control, power system protection, HW testbed</p>	 <p>Dr. Aboutaleb Haddadi PSCAD simulation, IBR controls</p>	 <p>Dr. Matthew Reno PICO design tool</p>	 <p>Dr. Rohitha Jayasinghe PSCAD-PSS/CAPE co-simulation</p>		 <p>Lucas Unruh PSCAD model co-simulation</p>	
 <p>Dr. Abhishek Banerjee IBR dynamics & controls, protection, HW testbed</p>	 <p>Dr. Deepak Ramasubramanian Hardware setup, IBR controls, and system studies lead</p>	 <p>Dr. Daniel Kelly PICO design tool</p>	 <p>Dr. Sandro Aquiles-Perez PSCAD-PSS@CAPE co-simulation</p>	 <p>Eric Mellick PSCAD-PSS/CAPE co-simulation</p>			
 <p>Dr. Suat Gumussoy PICO design tool optimization</p>	 <p>Dr. Tapas Barik HW testbed - Protection</p>	 <p>Dr. Liangyi Sun PSCAD-PSS@CAPE co-simulation</p>	 <p>Thomas Cummings PSCAD-PSS@CAPE co-simulation</p>		 <p>Dr. Aditya Ashok Real-time modelling & HIL</p>	 <p>Meredith Chee Utility Advisor</p>	
 <p>Swen Elpelt PHIL testbed</p>	 <p>Shuvangkar Das HW testbed - Inverters</p>	 <p>Alex Stinskiy Siprotec</p>		 <p>Dr. Zerui Dong Real-time modelling & HIL</p>		 <p>Addison Li Utility Advisor</p>	
						 <p>Steve Sano Utility Advisor</p>	

Agenda & Key Messages from our evaluation for Hawai'i Island

1

Fault-Ride Through functions successfully limit Grid-forming Inverter currents

2

POTT and LCD protection schemes clear faults in inverter-dominated transmission systems in 100ms

3

Co-simulation of high-fidelity IBR & relay models supports protection analysis in IBR-dominated systems

4

Protection-inverter co-design reveals need for good configurations to avoid expensive all-LCD schemes

| Contact

Published by Siemens Research and Predevelopment

Ulrich Muenz

Principal Research Scientist for Advanced Control & Optimization

FT RPD FOA

755 College Road East

Princeton, NJ 08540

United States of America

Phone +1 609 216 0170

E-mail Ulrich.Muenz@Siemens.com

