

STATCOM Strategy and Application in East Germany

Hybrid-Solutions and Grid Forming

21.07.14 | PhD Florian Sass, Cornelius Heck & Roman Hinz

Introduction



Florian Sass

- System Operations
- Voltage Control Expert



Cornelius Heck

- Strategic Grid Planning
- Team lead stability analysis & large projects (HVDC / Offshore)



Roman Hinz

- Asset Manager HVDC/FACTS
- Technical responsible for Hybrid-STATCOM tender process







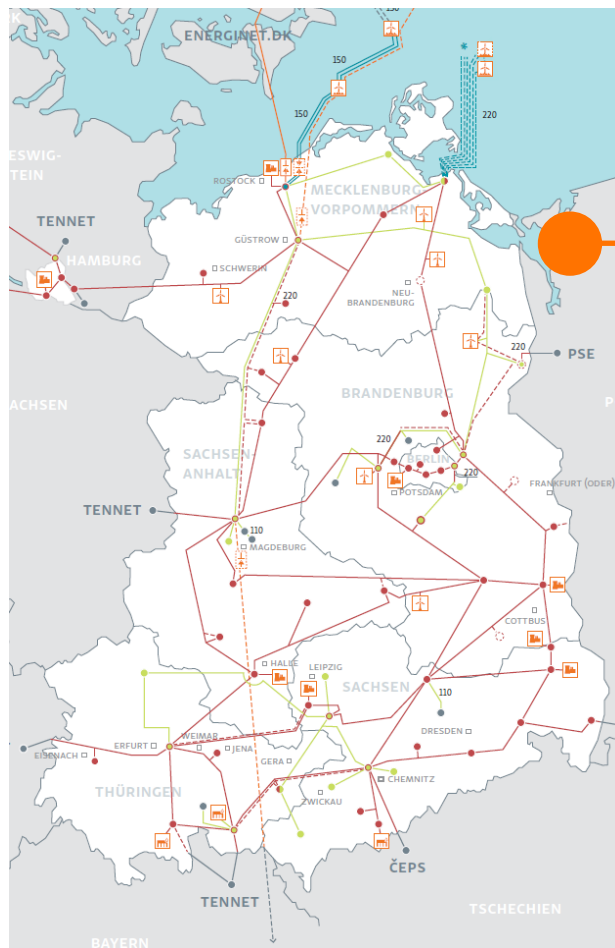

The TSO 50Hertz is responsible for ...

- ... securing the electricity supply of 18 million people in northern and eastern Germany 24/7
- ... operating the electrical system in Berlin, Brandenburg, Hamburg, Mecklenburg-Vorpommern, Saxony, Saxony-Anhalt and Thuringia
- ... operation, maintenance, expansion and safety of the extra-high voltage grid – onshore and offshore



50Hertz – at a glance



	2020	2010
 RES share in power consumption	62 %	~ 25 %
 Installed capacity thereof wind thereof photovoltaics	57 GW (~ 26 %) 20 GW (~ 32 %) 13 GW (~ 27 %)	38 GW (~ 35 %) 11 GW (~ 40 %)
 Power consumption	ca. 101 TWh (~ 20 %*)	ca. 98 TWh (~20 %)
 Turnover	11,1 bn €	5,6 bn €
 Staff	1.254	643



50Hertz – at a glance

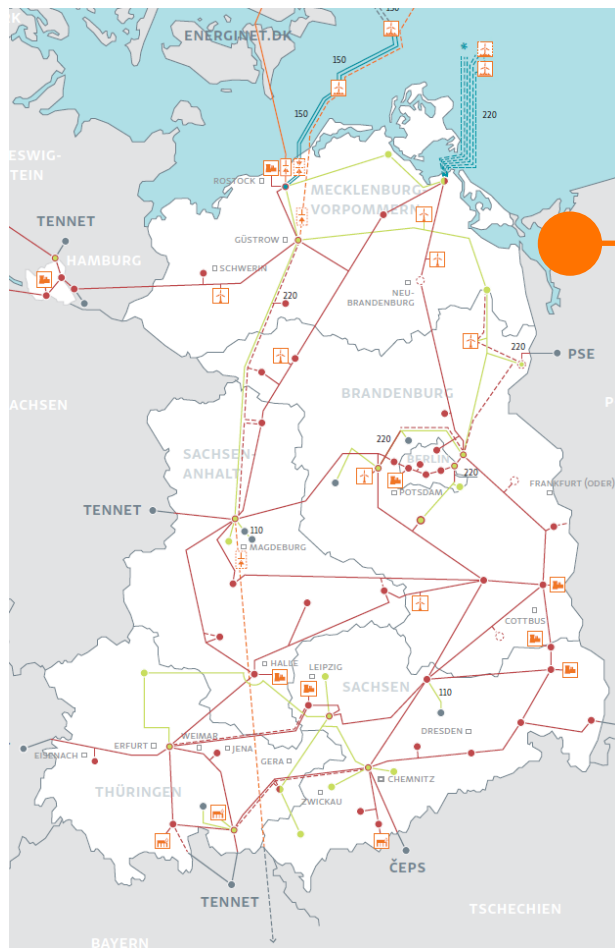

	2020	2032
RES share in power consumption	62 %	~ 100 %
Installed capacity thereof wind thereof photovoltaics	57 GW (~ 26 %*) 20 GW (~ 32 %) 13 GW (~ 27 %)	30 GW 18 GW
Power consumption	ca. 101 TWh (~ 20 %*)	

“From 60 to 100 until 2032“



Installed RES capacity in the 50Hertz grid area is steadily increasing

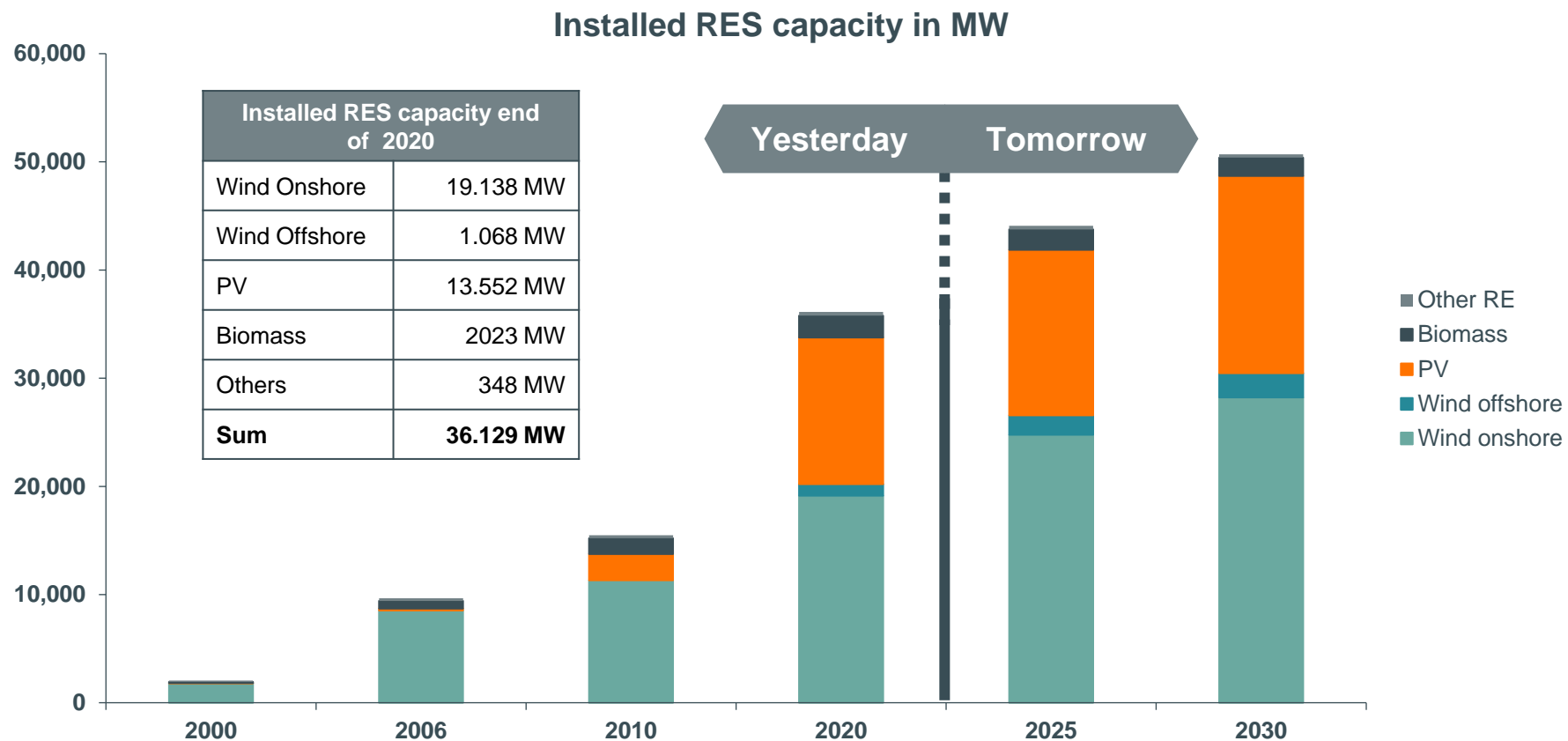

Source: 50Hertz; *Preliminary Data as of 21.01.21



50Hertz – at a glance

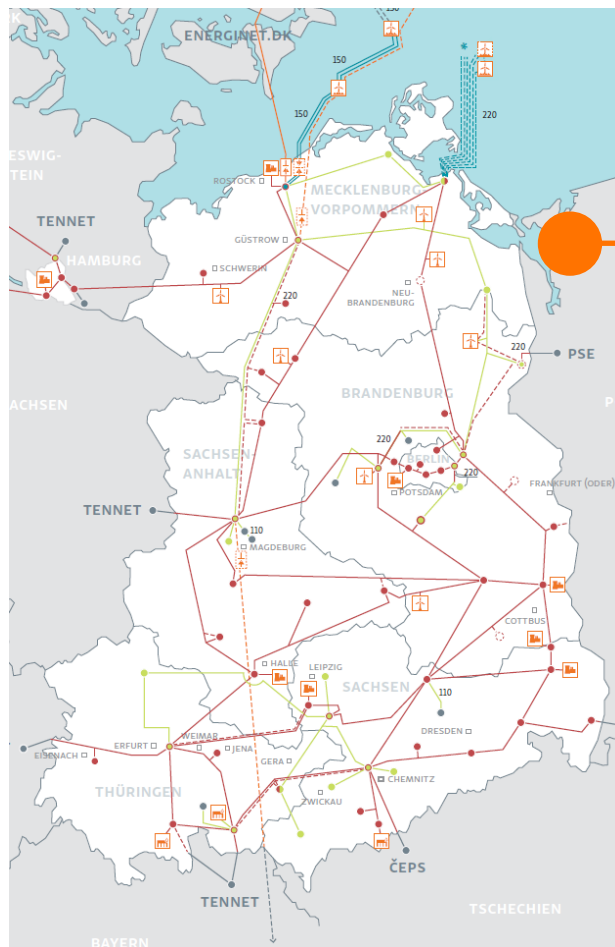

High share of RES results in volatile power flows and high transits

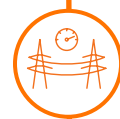

Massive grid expansion during the last years
Double line circuits for 80% of all lines



Loss of reactive power sources due to coal phase out



Increasing costs for voltage related redispatch



Current Challenges as Grid Operator

- Volatile generation and small scale assets
 - Increasing number of switching actions
 - Increasing complexity of system operations
- Shift in power generation regarding location and voltage level
 - Decreasing reactive power reserves for *static voltage control*
 - Increasing voltage sensitivity of system requires *dynamic voltage control*

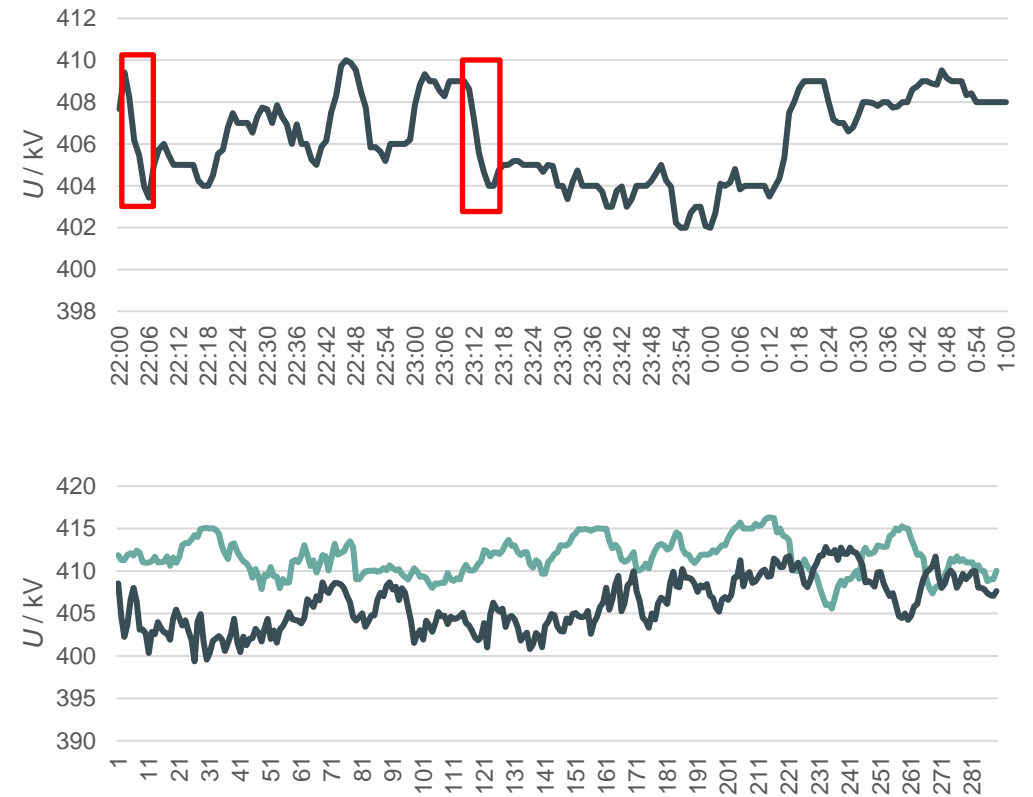

Operational need for flexible, automated and dynamic impact on grid voltage



Where are we heading?

Development of transport capacity

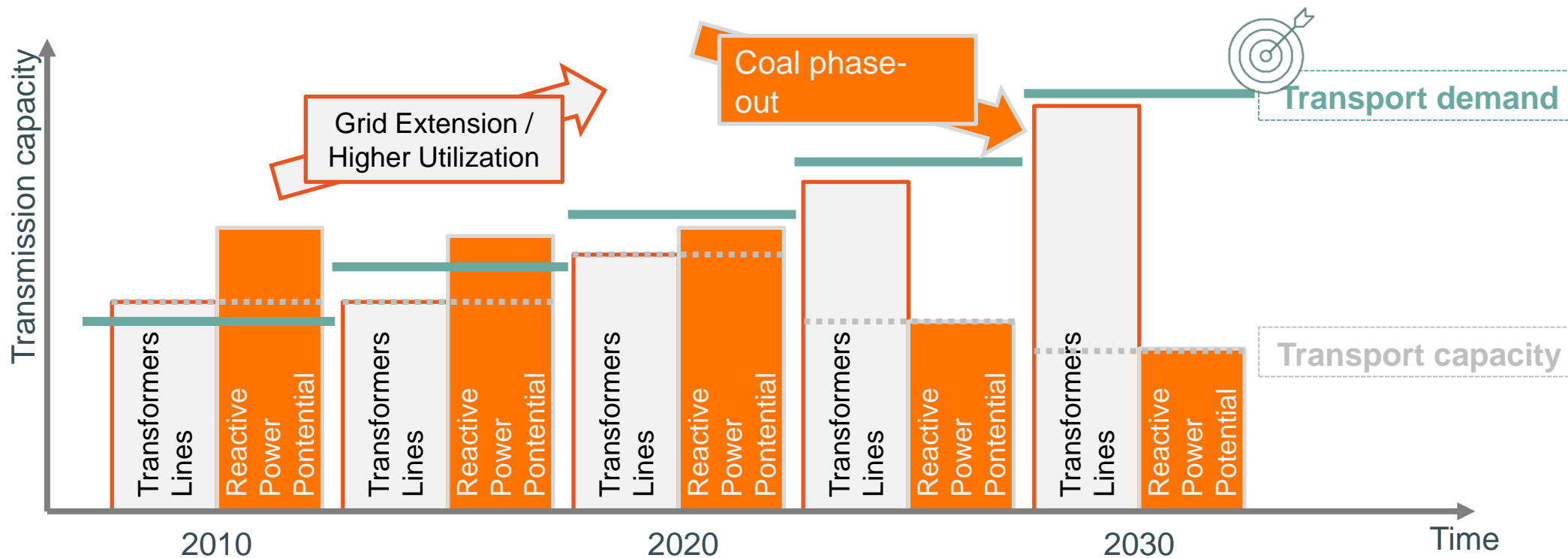

In order to meet the transport demand the gap in reactive power must be closed.



Key questions for a stable system operation

- 1 How much compensation is needed?
- 2 What kind of compensation is needed?
- 3 Are there other ways of compensation?

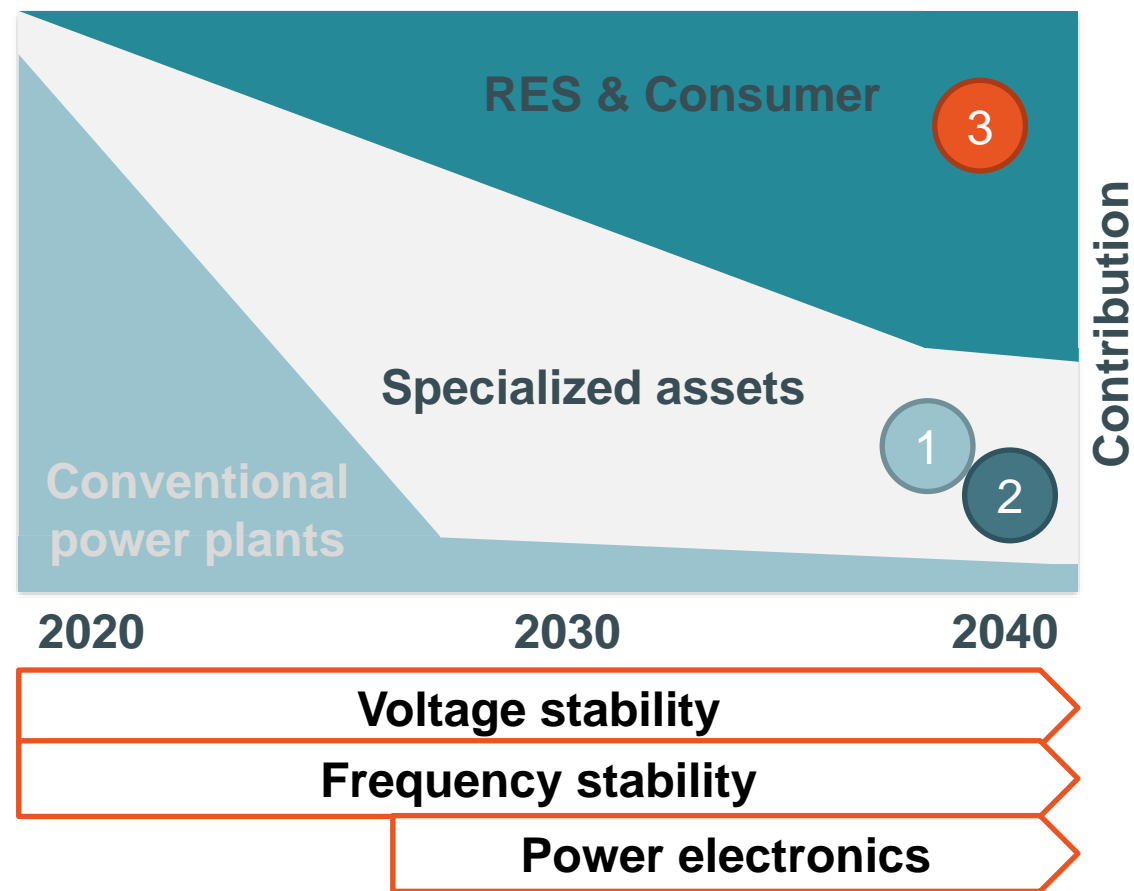

Reactive Power – Grid Development Plan

Additions in reactive power compensation 2035



$$\text{Deficit} = Q_{\text{Load}} + Q_{\text{Grid}} - Q_{\text{Potential}}$$

7 Gvar

7 Gvar

9 Gvar



Instabilities in federal grid development plan

Example of short-circuit on a line

2

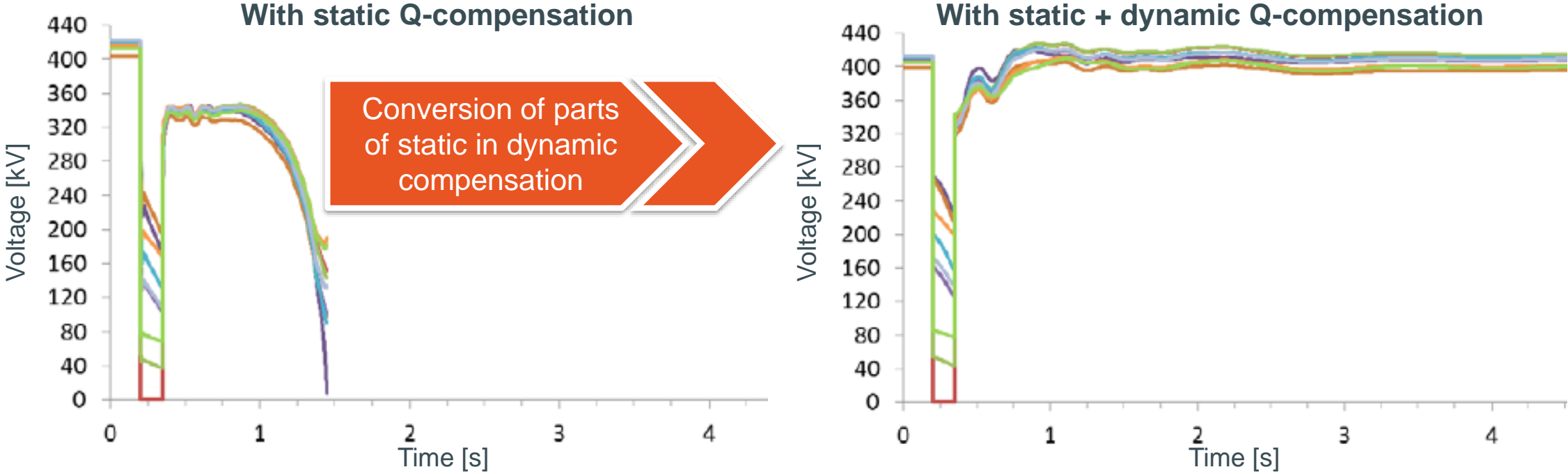

Implementation of fast dynamic reactive power needed to stabilize the grid.



Source: https://www.netzentwicklungsplan.de/sites/default/files/paragraphs-files/NEP_2030_V2019_2Entwurf_Systemstabilitaet.pdf, p. 6 & 8

Frequency stability – will there be problems?

1

>100 GWs needed

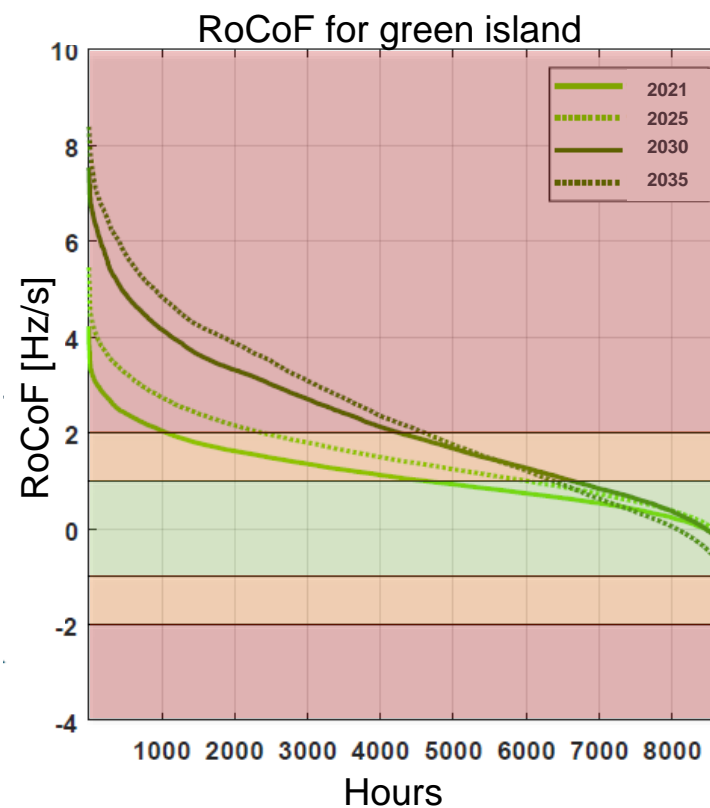
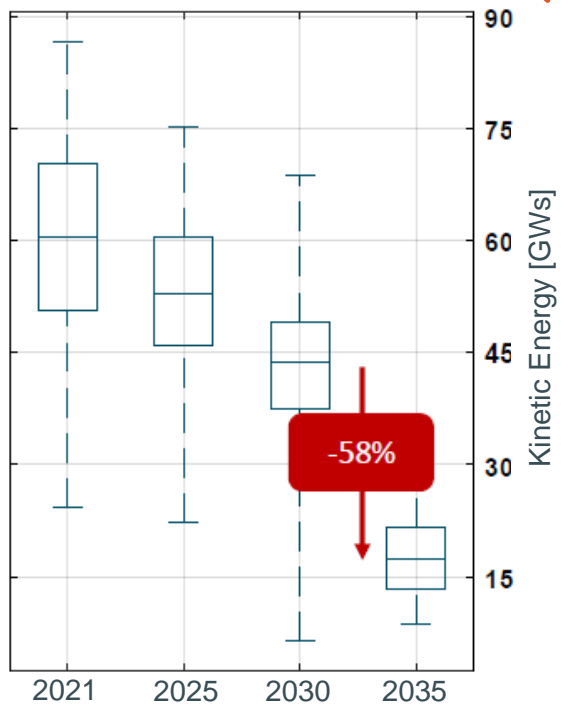

System split poses a dangerous thread!



Any issues due to grid-following generation?

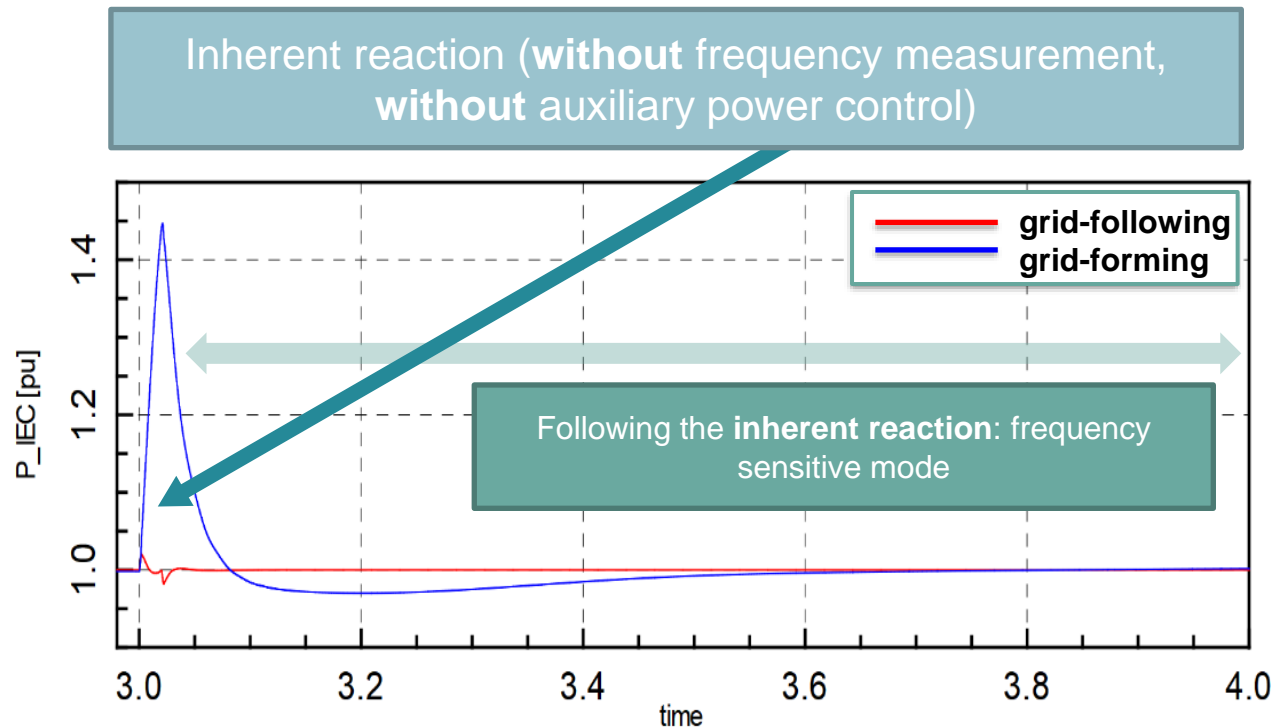
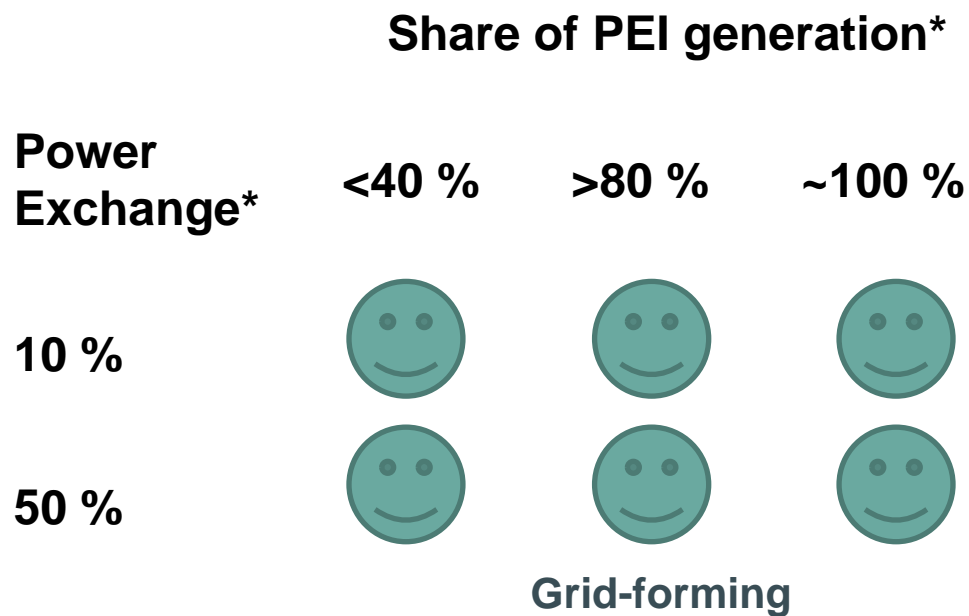
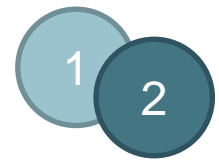

Fast roll-out of grid-forming control necessary to maintain stable conditions



*of the total generation of the remaining island

What do we know?

Quantity

↑ Export and transit through the 50Hertz area
→ demand of reactive power & inertia

↓ Nuclear & coal phase out in Germany
→ reactive power potential & inertia

➤ **Large amount compensation in the 50Hertz control area necessary.**

Quality

↑ Cross-boarder trade & transport distance
→ load flow changes & impact of short circuits

↑ Penetration of PE-interfaced generation

↓ Synchronous generation

➤ **Compensation needs to be dynamic, fast and grid-forming with virtual inertia**

Specialized assets are imperative to secure stable system operation.



What is our plan?

- 3 stages of STATCOM roll-out
- standardization with ± 300 Mvar
- extended swing-range with static compensation
- grid-forming control
- with short term storage

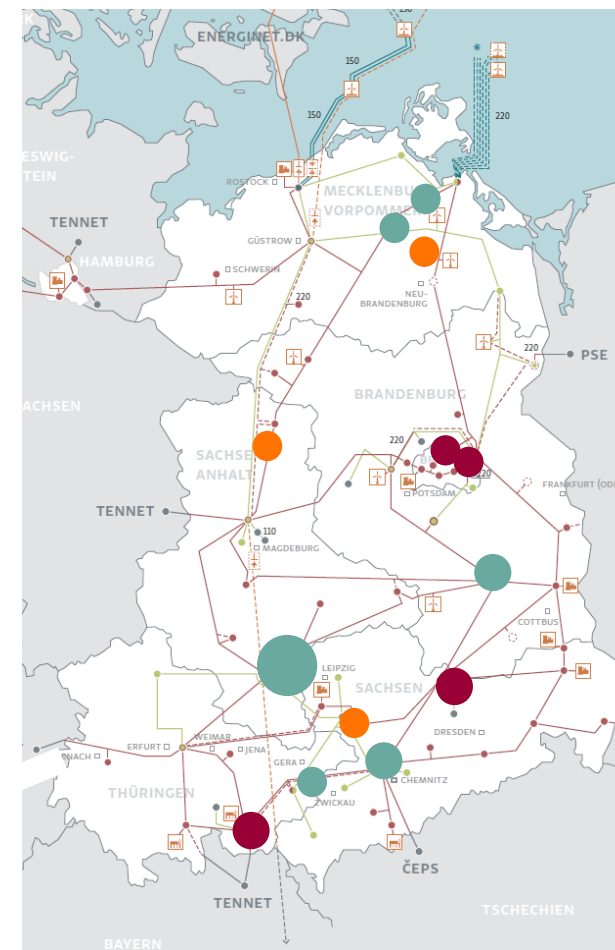

STATCOM identified as optimal asset to satisfy all needs



First Hybrid-STATCOM in Germany – StC201 Lubmin

STATCOM ±100 Mvar + 200 Mvar TSR (Commissioning 2018)

TSR – Thyristor Switched Reactor

Control Building

STATCOM Valve Hall & Valve Cooling



TSR Reactors

STATCOM Outdoor Cooler

UW Lubmin StC201 - Siemens



Phase 1 from 2025

8 Hybrid-STATCOM (SVS)

- Multilevel STATCOM with ± 300 Mvar (max. two branches)
- Turn Key: Incl. Civil and Erection
- Manufacturer independent HMI for SCADA
- Black Start Support Function (incl. optimized diesel generator operation)
- Control Functions:
 - Dynamic and quasi stationary voltage control
 - Active Filtering
 - Negative Sequence
 - Power Oscillation Damping
 - Hybrid Capability: MSCDN/TSC and MSR/TSR

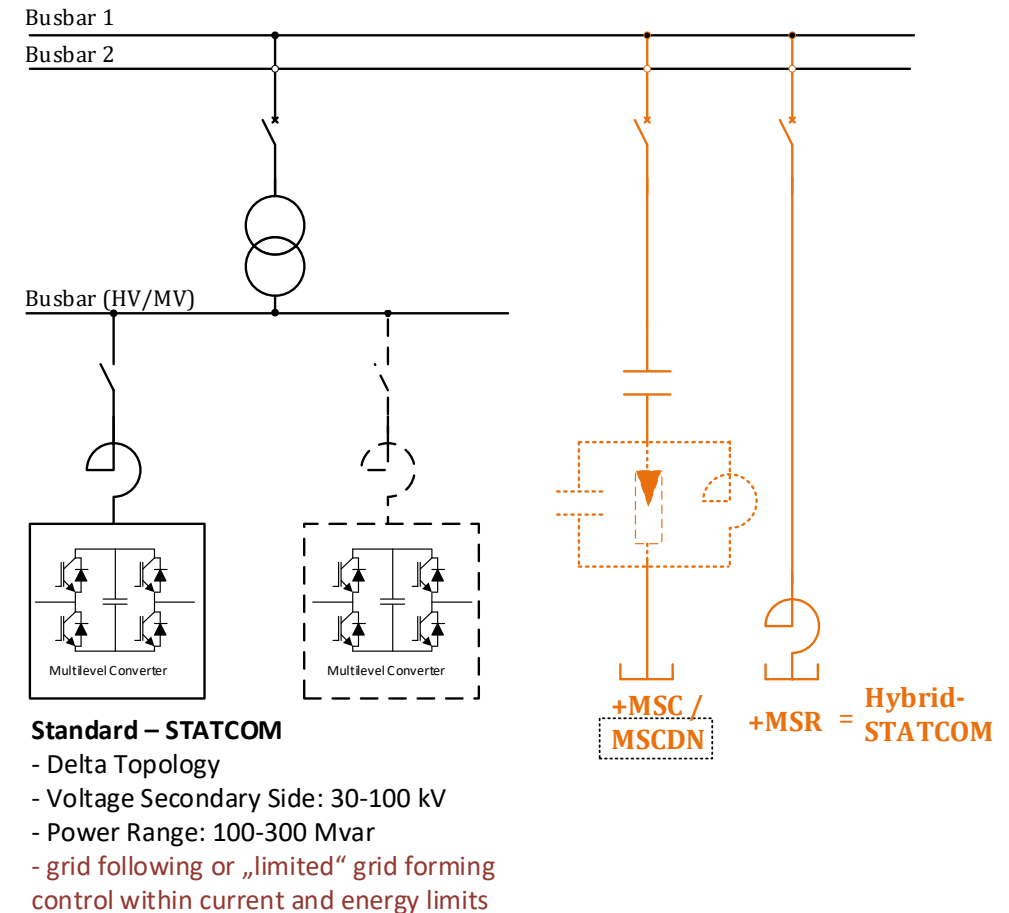

Phase 1 from 2025

Footprint

Standardization of Layout:

Goal to create a manufacturer independent basic design

- 2 Layouts 60 m x 60 m & 42 m x 75 m
 - STATCOM-Layout to be defined for standardization
 - Manufacturer is allowed to adapt the design if necessary (additional green area)
- Optimization of Layout Concepts
 - Predefined single line diagram for auxiliary power supply and primary equipment
 - Technical specification for civil
 - Manufacturer has flexibility to adjust

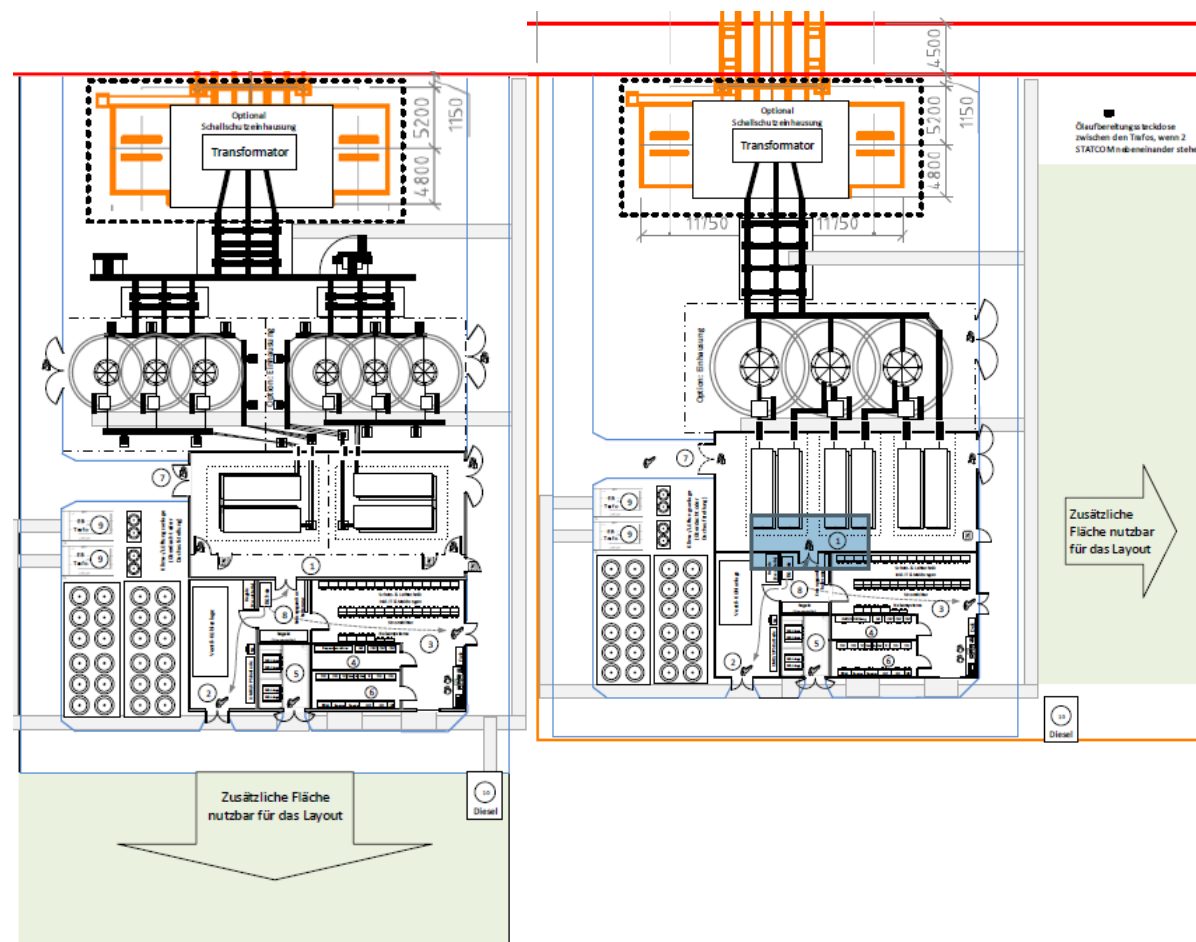

Phase 1 from 2025

Standard building incl. in tender

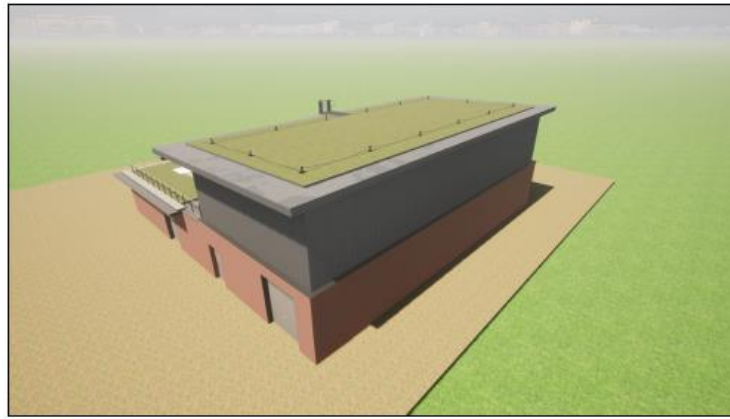
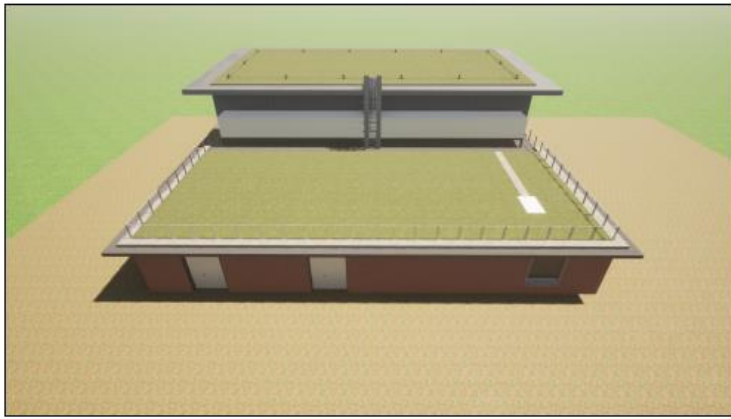
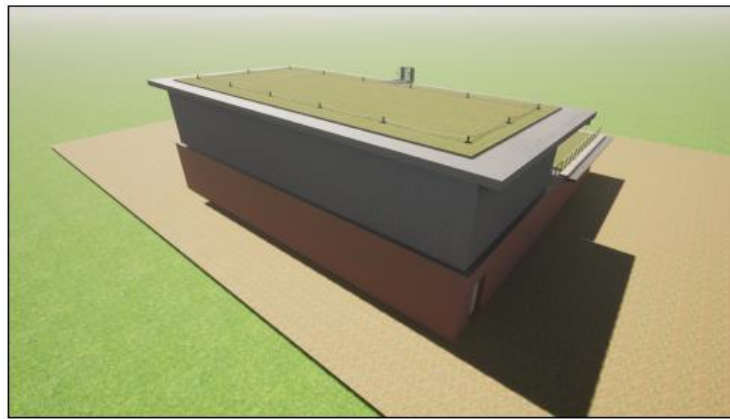
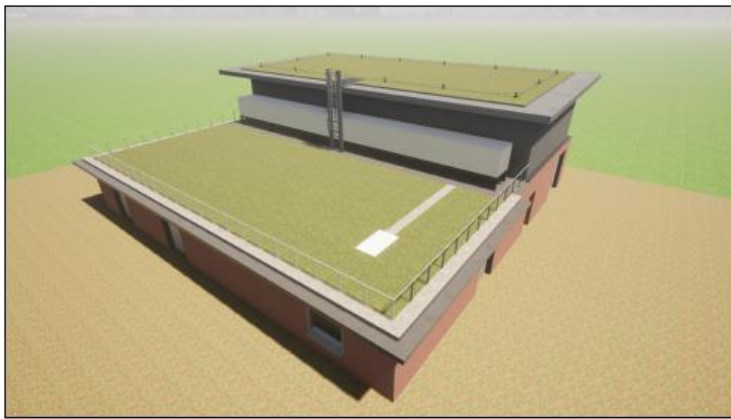

Note on STATCOM Control

- Switching of submodules generates sinus voltage curve synchronous to grid voltage.
- Reactive power will be controlled via difference of converter side voltage amplitude to grid voltage
- Voltage angle in steady state (without contingency) is zero.
- Converter voltage angle difference to grid voltage causes active power flow

$$Q_{PCC} \approx \frac{3U_{PCC}^* (U_N \cos \delta - U_{PCC}^*)}{X_N},$$

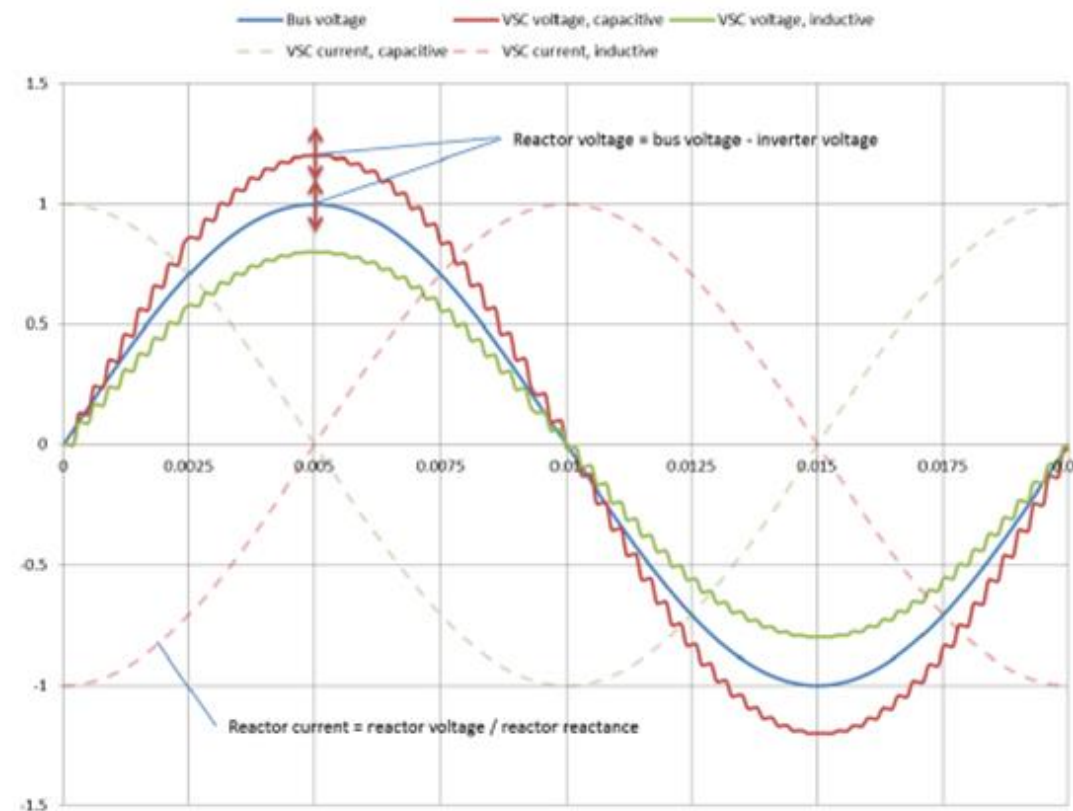

Source: GE Grid



Note on STATCOM Control

- Switching of submodules generates sinus voltage curve synchronous to grid voltage.
- Reactive power will be controlled via difference of converter side voltage amplitude to grid voltage
- Voltage angle in steady state (without contingency) is zero.
- Converter voltage angle difference to grid voltage causes active power flow

$$Q_{PCC} \approx \frac{3U_{PCC}^* (U_N \cos \delta - U_{PCC}^*)}{X_N}$$

$$P_{PCC} \approx \frac{3U_N U_{PCC}^* \sin \delta}{X_N}$$

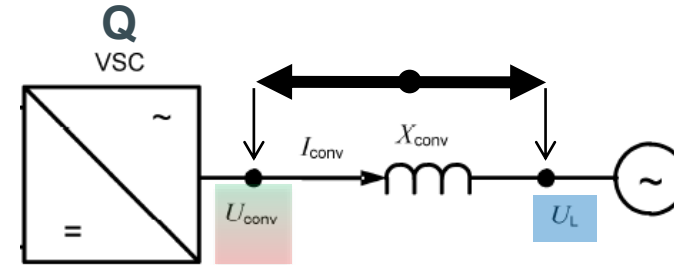

Source: DIN IEC TR 62543

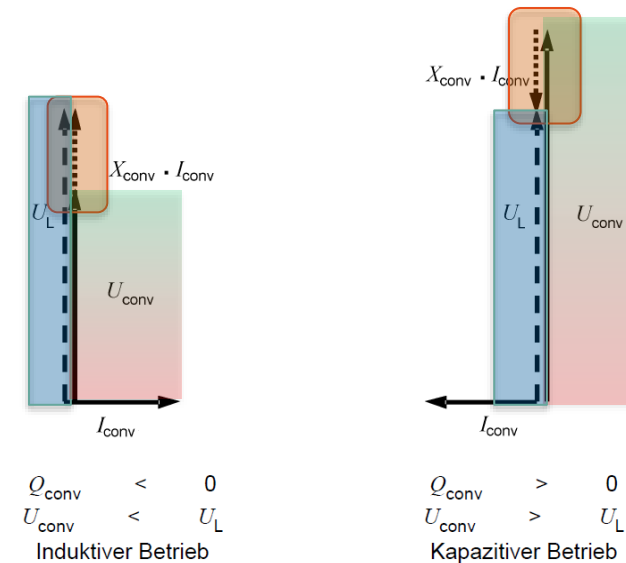

Phase 2 & 3

STATCOM with Short Time Energy storage via Capacitor Banks

- No Pilot Project available
- Several topologies and energy storage systems available
- Which is the cost efficient one and what to specify for the manufacturers?

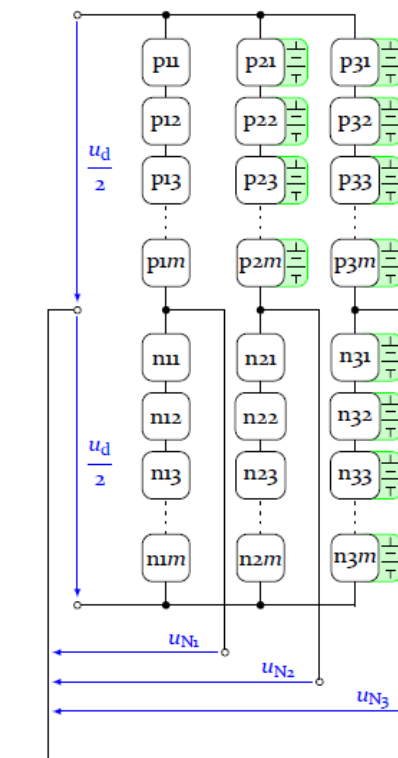
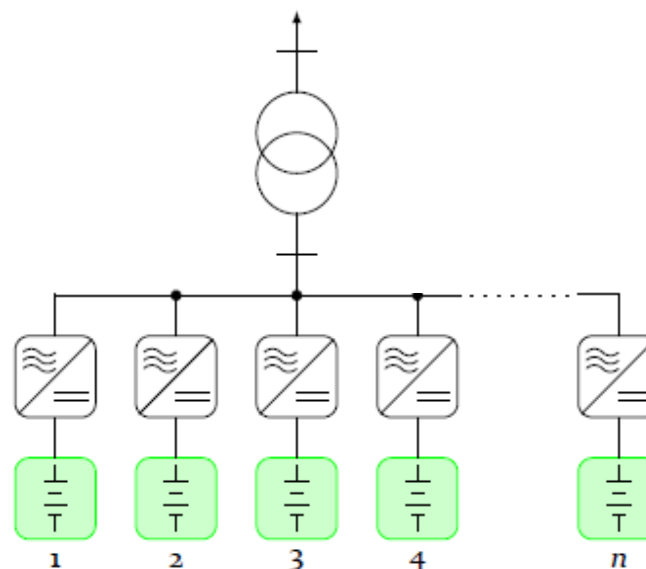

Dissertation: Multidirektionale Energieflusssteuerung eines Modulare Multilevel-Umrichters mit integrierten Batteriespeichern in elektrischen Netzen



Phase 2 & 3

Specification of STATCOM with Energy Storage System

To be identified/specified:

- Design options?
- Topology and bottlenecks?
- Operation characteristics: Charging / Discharging
- What are the asset-relevant changes to the standard design?
- Product Maturity for tender?
- Experiences with energy storage systems? (maintenance, aging, spares)

→ Several Suppliers confirmed to be able to tender in 2022

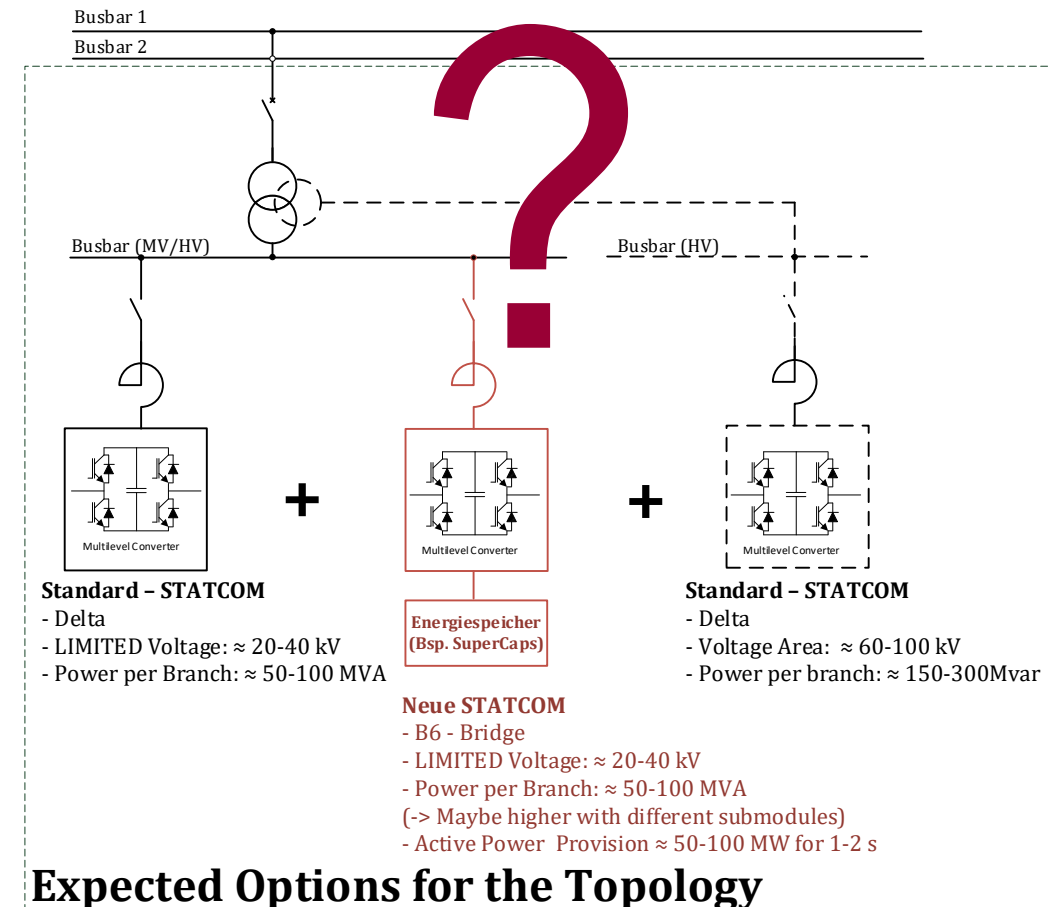

Conclusion

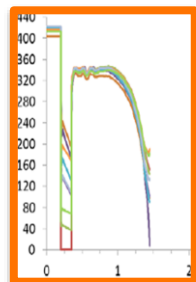

Transient stability



Load flow changes

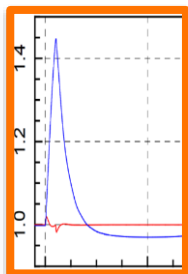

PEI Penetration

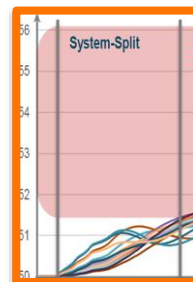

Frequency stability

Standardized grid-forming STATCOMs with short term storage.



Thank You

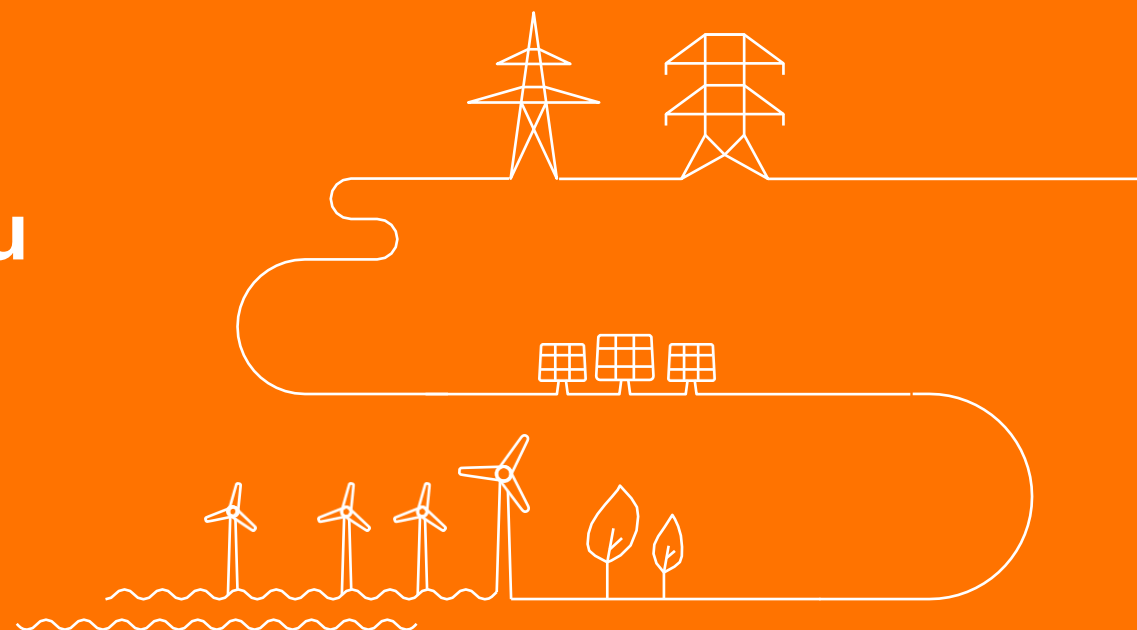

What is Grid Forming / Voltage impressing Control

„Grid Following Control“

Design Today: „Quasi Current Source“

Converter has voltage control at outer control scheme but the internal control is a current controller which follows the grid conditions (e.g. PLL).

The correct adjustment of current phasor has an impact of the stability of the voltage phasor at the PCC. The voltage phasor is volatile during contingencies

Problem:

Voltage is quickly adjusted but
The voltage quality is unstable

With more converters in the
grid more voltage distortion
during voltage angle jumps.

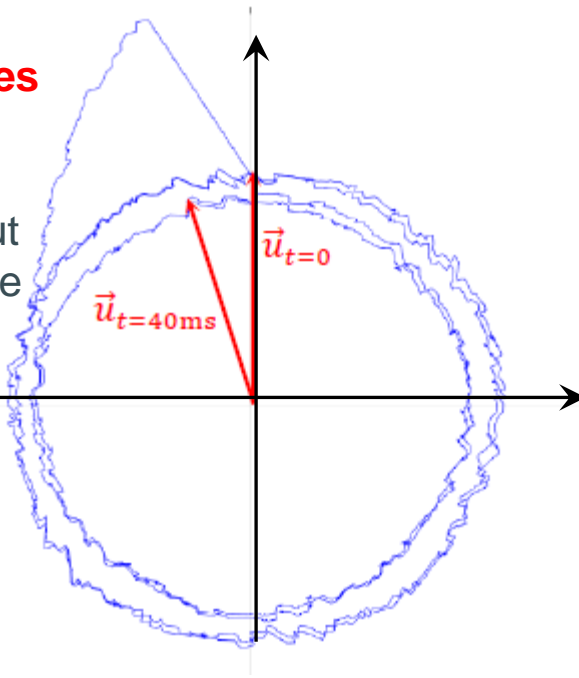

„spannungseinprägende Regelung“

Design of tomorrow: „Quasi Voltage Source“

Inner Control acts as voltage source which keeps the voltage phasor stable/constant even during grid impedance changes.

DEFAULT VOLTAGE AT THE PCC

When the voltage is controlled during voltage angle jumps it will be quickly adjusted to the set point.

The converter will act withing
its current limits.

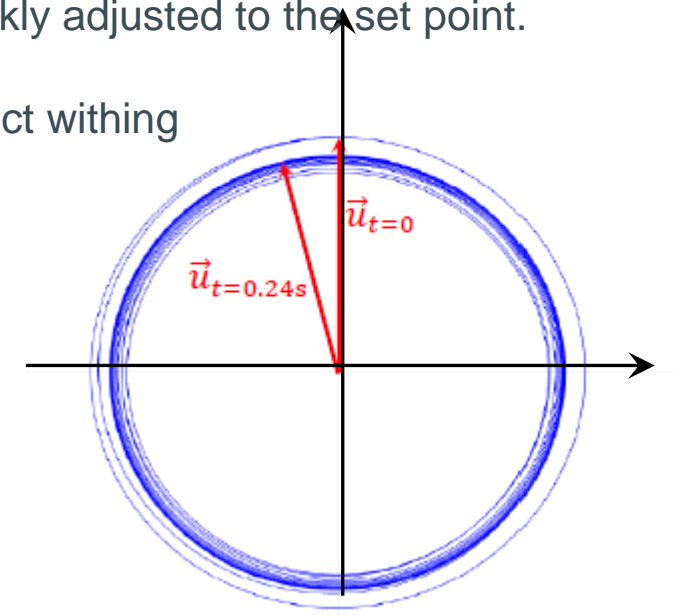

What is Grid Forming / Voltage impressing Control

The constant voltage phasor will demand instantaneous reserve in form of active power

Grid Following Control

Design today: „Quasi-Current Source“

Netzstrom (schwarz: Sollwert, rot: Istwert)

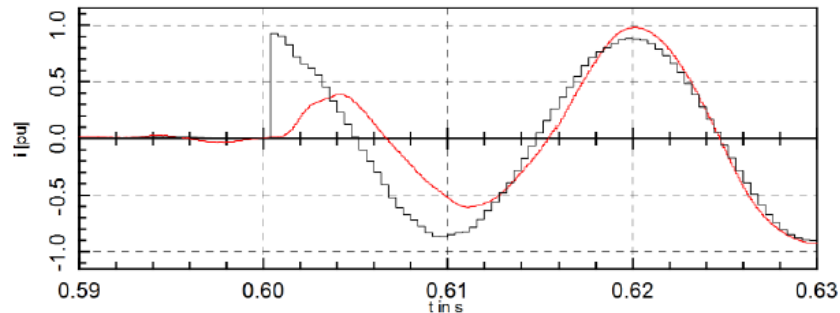

Current

Netzspannung (schwarz) und Stellspannung (rot)

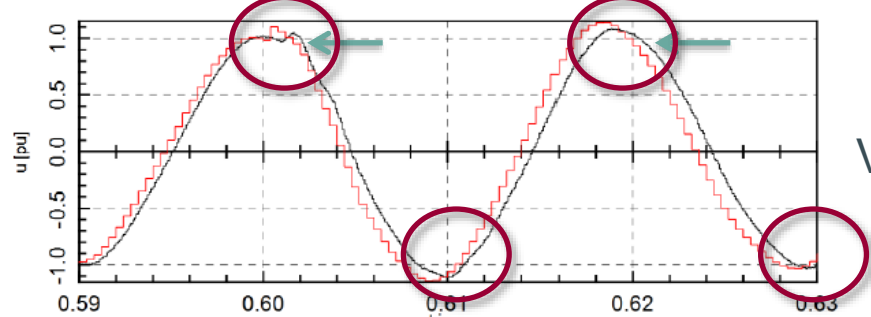

Voltage

Stromeinprägende Regelung

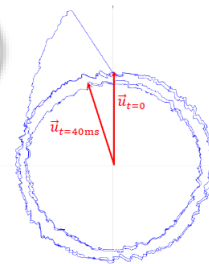

Grid Forming Control

Design tomorrow: „Quasi Voltage Source“

Netzstrom (schwarz: Idealer Wert, grün: Istwert)

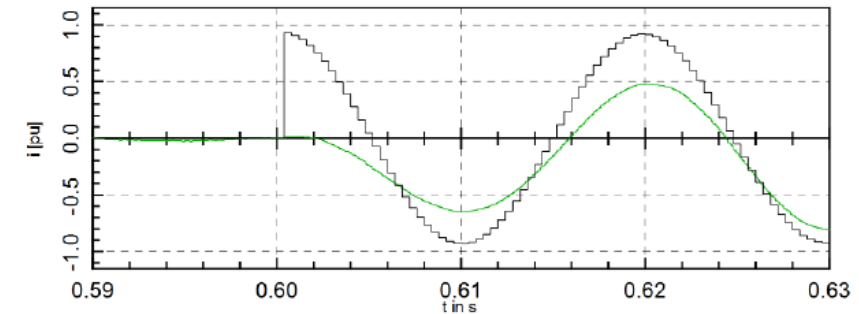

Current

Netzspannung (schwarz) und Stellspannung (grün)

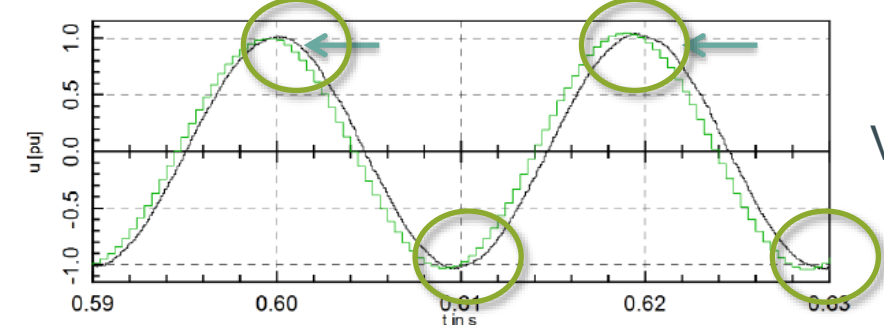

Voltage

Spannungseinprägende Regelung

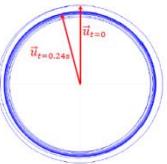

Intrinsic Stability II

DigSILENT Stability analysis for system design – B2025

- Small signal stability leads to system instability even without disturbances.
- MSCDN amplify small signal events.
- RES necessary to allow a “flat-run”
- Activation of RES potentials is a key factor to achieve a stable system operation

Additional STATCOM are needed to withstand all perturbations

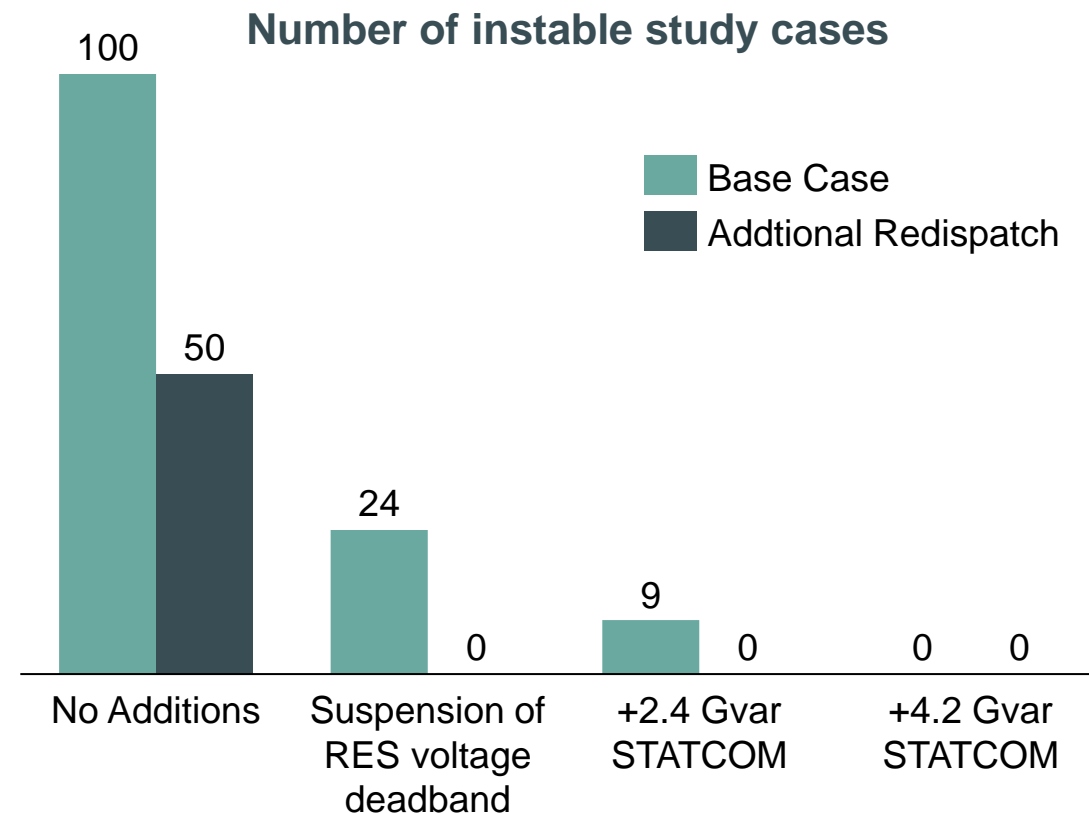

Frequency stability

2

Without additional inertia

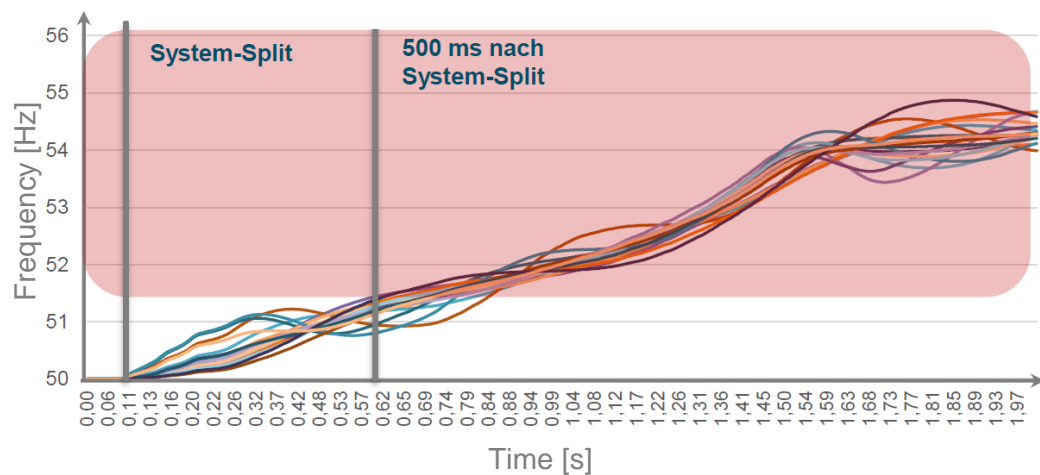

With additional inertia

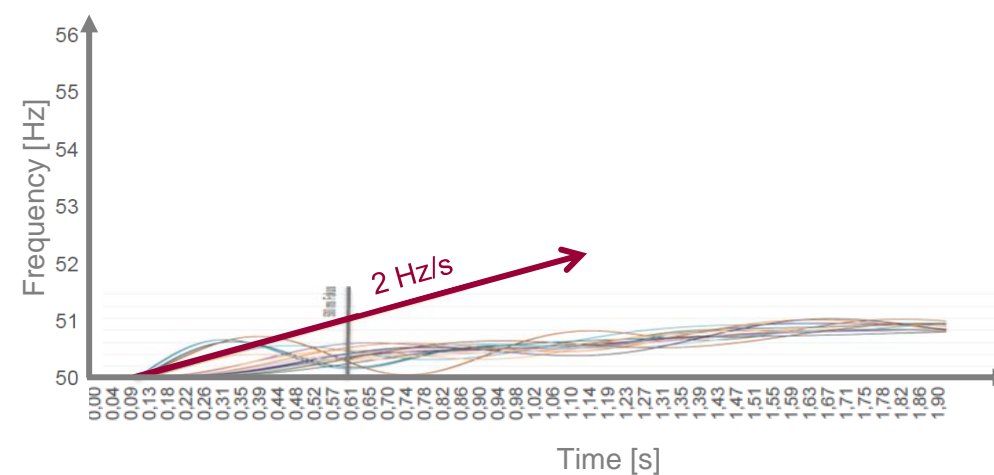

With additional inertia RoCoF related issues can be averted.



STATCOM

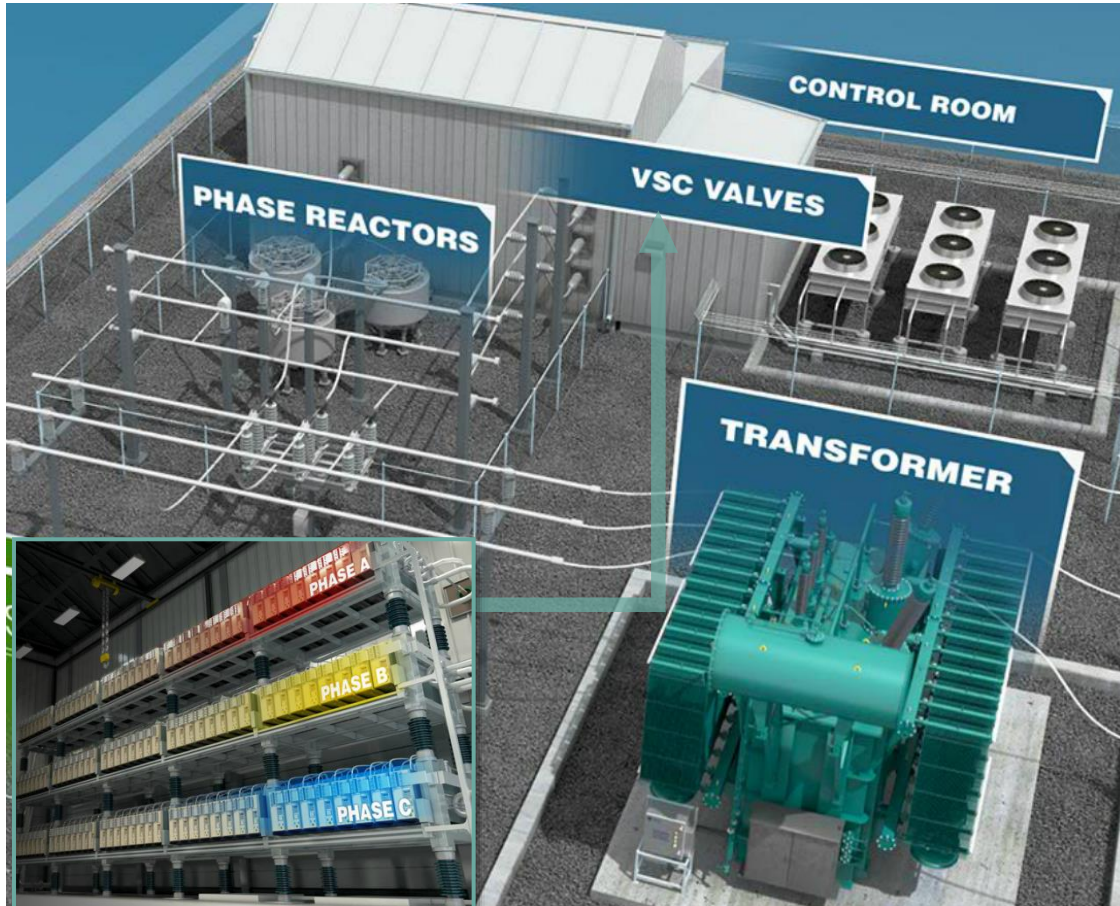

Quelle: GE Grid: <https://www.gegridolutions.com/productexplorers/statcom/>

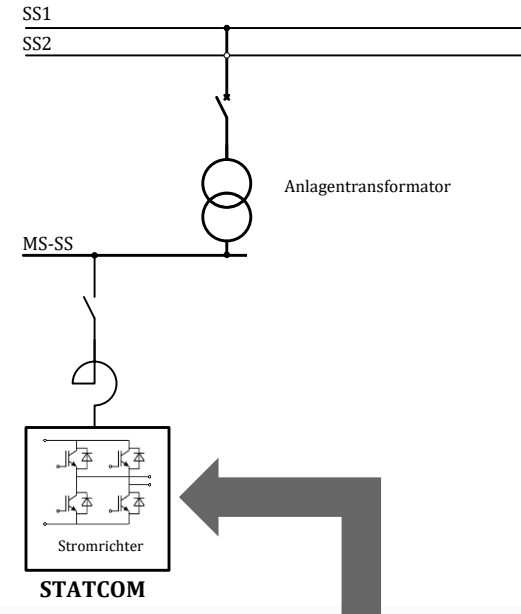

Quelle: GE Grid

Phase1 until 2025: Support of Black Start

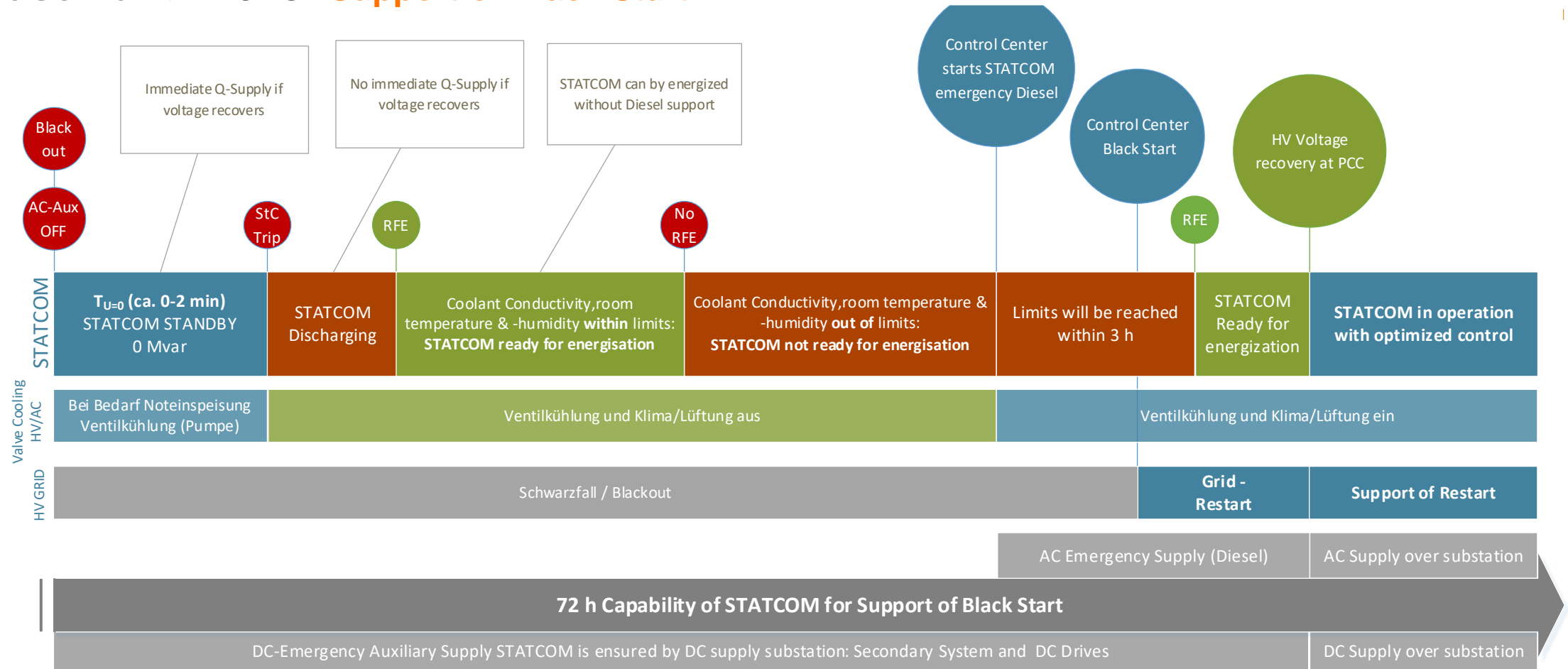

- RFE: Ready for Energization
- Trip: STATCOM-Circuit Breaker off and Submodules discharging
- AC-Aux: AC Auxiliary Power Supply
- T_{U=0}: Time after Voltage went to 0 kV until STATCOM Trip activated (CB off)
- in operaton
- not in operation, but ready for energization
- not in operation, & not ready for energization

General Converter Control

- Zwischen STATCOM und Netz wirkt die induktive Impedanz von Drossel und Transformator. Jede der vom STATCOM erzeugte Spannung ist zu der jeweils korrespondierenden Netzspannung **um den selben** Phasenwinkel ν verschoben.

$$P_{\text{PCC}} \approx \frac{3U_N U_{\text{PCC}}^*}{X_N} \sin \delta,$$

$$Q_{\text{PCC}} \approx \frac{3U_{\text{PCC}}^* (U_N \cos \delta - U_{\text{PCC}}^*)}{X_N},$$



Bild 3.8 a. Ankopplung des STATCOM ans Energienetz über einen Transformator
 b. Dreiphasige Ersatzschaltung, Transformator wird durch die Kurzschlußinduktivität L_k repräsentiert
 c. Einphasige Ersatzschaltung und zugehöriges Zeigerdiagramm

Spannungswinkel = 0

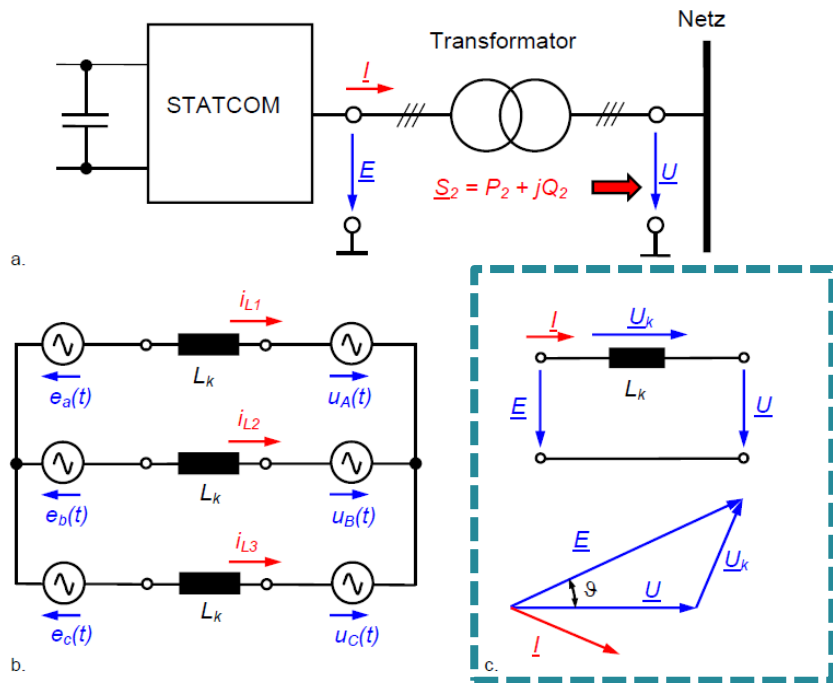
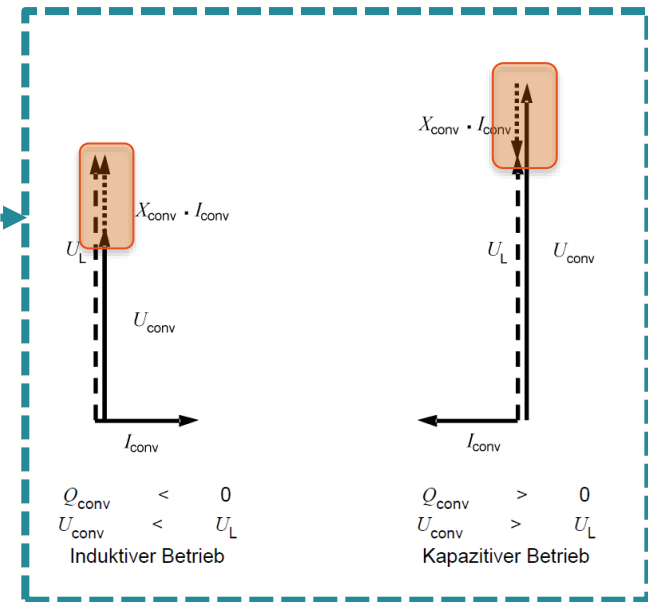

STATCOM with MMC

Delta Topology instead of B6-Bridge (HVDC)

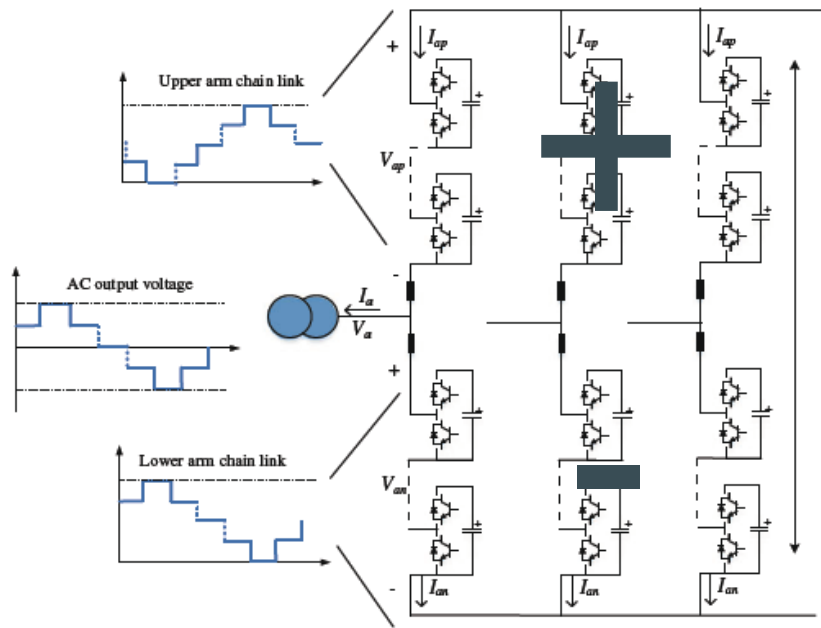

B6 Bridge



Bild A.5 – Modularer Mehrstufenstromrichter

**Delta Topology (less submodules Submodule)
Full Bridge required as submodule design**

STATCOM-Roadmap

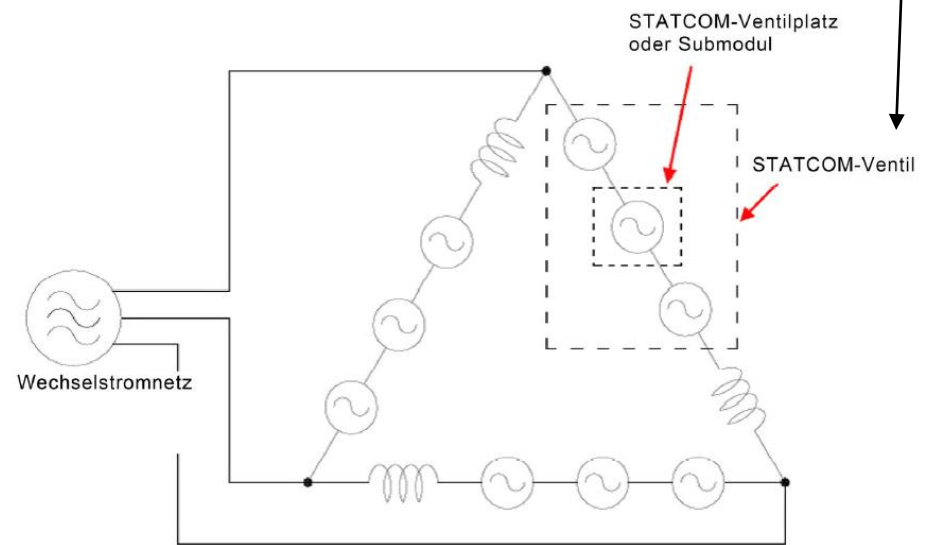
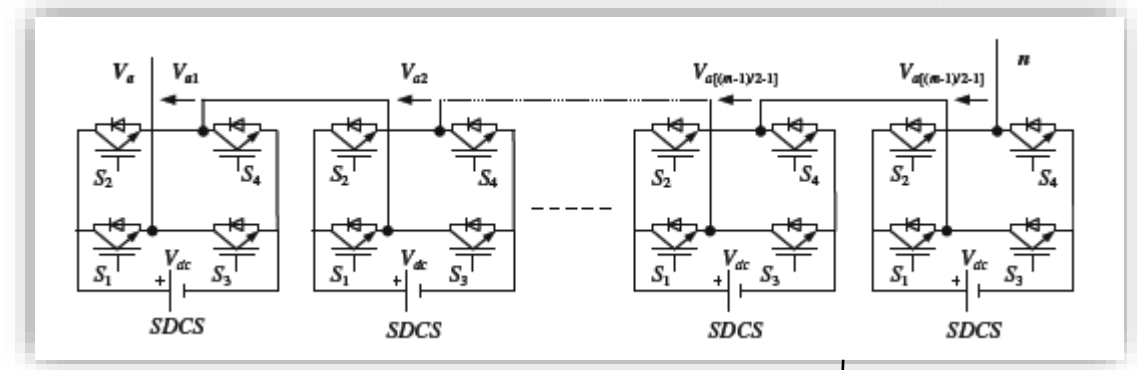

STATCOM: $\Sigma 2400$ MVAR
MSCDN: $\Sigma 900$ MVAR

STATCOM: $\Sigma 1800$ MVAR

STATCOM: $\Sigma 1500$ MVAR

	Size / MVAR	Type	Location	CMS
1. Planning Phase	+1200 / -600	2xSTATCOM (GF*) + 2xMSCDN	Lauchstädt	2025
	+600 / -600	2xSTATCOM (GF*)	Ragow	
	+900 / -600	2xSTATCOM (GF*) + MSCDN	Area Röhrsdorf	
	+600 / -600	2xSTATCOM (GF*)	Area Siedenbrünzow	
(Phase 1) Tender 2021				
2. Planning Phase	+600 / -600	2xSTATCOM (GF+FS*)	Area Streumen	2028
	+600 / -600	2xSTATCOM (GF+FS*)	Area Remptendorf	
	+600 / -600	2xSTATCOM (GF+FS*)	Area Berlin	
(Phase 2) Tender 2022				
3. Planning Phase	+300 / -300	STATCOM (GF+FS*)	Area West Sachsen (Eula)	2030
	+300 / -300	STATCOM (GF+FS*)	Area Prignitz (Perleberg)	
	+300 / -300	STATCOM (GF+FS*)	Area Ost Sachsen (Schmölln)	
	+300 / -300	STATCOM (GF+FS*)	Area Uckermark (Vierraden)	
	+300 / -300	STATCOM (GF+FS*)	Area Thüringen (Eisenach)	
(Phase 3)				

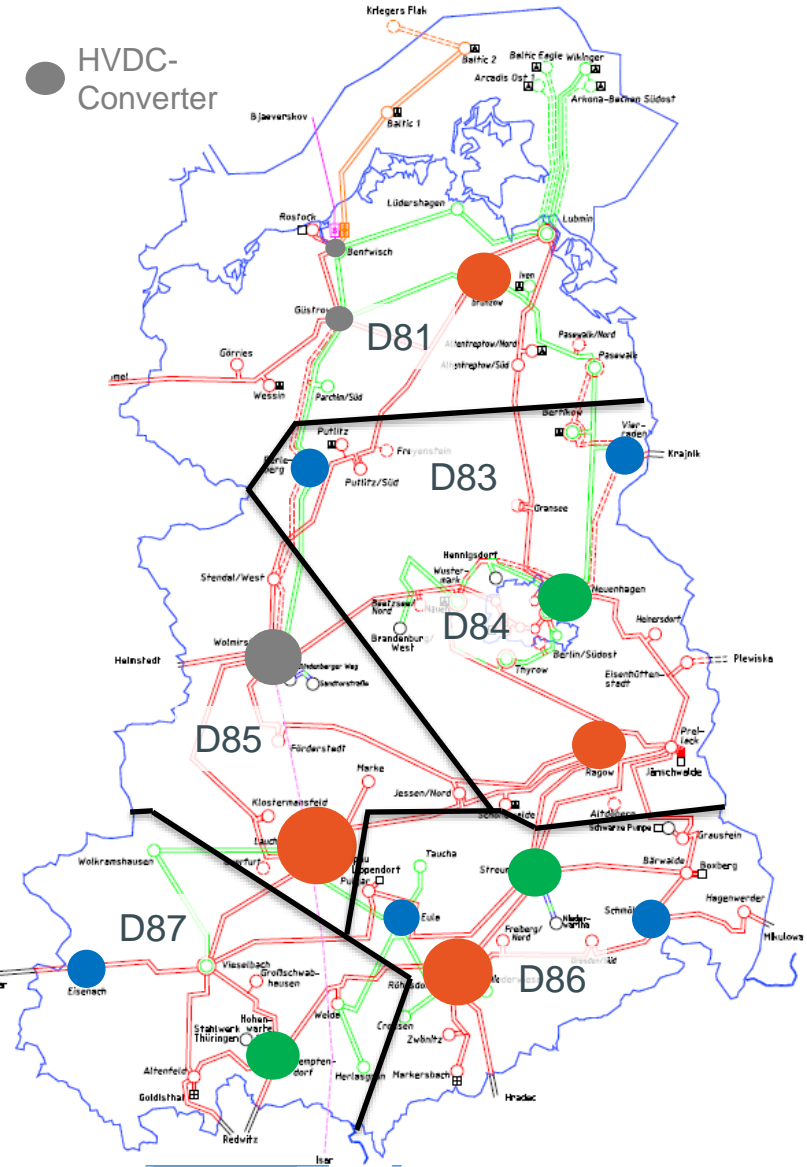

GF: „Limited“ Grid Forming without Capacitor Bank

*GF+FS : Extended Grid Forming incl. Frequency stabilizing =STATCOM with capacitor bank with synthetic inertia

Framework Agreement: **Several Hybrid-STATCOMs in one EU-Tender**

1. EPC-Single-Orders for each project:

- Taylor made: optimized design
- Long Timing: Separate EU tenders
- 4 times risk for suspension
- High number of spare parts
- Easy implementation of technical evolutions
- No fixed commercial conditions for future projects

2. Framework agreement:

- Only 1 procurement process
- Increased security of supply
- Partial standardization
- Fixed commercial conditions for electrical materials
- Lower number of spare parts
- Allows supplier relationship management

Framework agreement for EPC projects with mini-competition

- Flexibility with price optimization:
 - Partial standardization with an optimized design
 - Possibility to include new technologies
 - Price optimization due to mini-competition
- **Only 1 procurement process + mini competitions (+/- 3 months)**
- 1 time risk for suspension
- Fixed commercial conditions ease the process
- Allows supplier relationship management
- Increased security of supply



Phase 2&3 : STATCOM with Short Time Capacitor Banks

Besides conventional voltage control new functions are obligatory:

Positioning Paper 4 German TSO's:

https://www.netztransparenz.de/portals/1/Content/Weitere%20Ver%C3%B6ffentlichungen/4%C3%9CNB_Positionspapier_netzbildende_STATCOM_final.pdf

Grid Forming (incl. Voltage Impressing Function and Frequency Stabilizing)

- [FNN Guideline: Grid forming behaviour of HVDC systems and DC-connected PPMs \(Download\) - VDE-Shop der Verbandsgeschäftsstelle Frankfurt am Main: https://shop.vde.com/en/fnn-guideline-hvdc-systems-2](#)
- [Grid-Forming Capabilities: Towards System Level Integration \(entsoe.eu\): https://eepublicdownloads.entsoe.eu/clean-documents/RDC%20documents/210331_Grid%20Forming%20Capabilities.pdf](#)
- [Provision of fast frequency response by SVC plus frequency stabilizer | IET Conference Publication | IEEE Xplore: https://ieeexplore.ieee.org/document/7914481](#)

