

Testing IBRs Participation in Wide-Area Stability Services

Presenter: V. Gevorgian (NREL)

Team: S. Shah, P. Koralewicz, W. Yan, R. Wallen,
E. Mendiola, J.H. Choi

2024 ESIG Spring Technical Workshop

Tucson, AZ March 27, 2024

Motivation

- Current stability paradigm:
 - Decentralized and uncoordinated control to responds to local measurements (mainly PSS)
- IBRs are not used for stability services:
 - They can provide reliability service (proven, but not used)
 - Can provide damping services if properly controlled (needs to be demonstrated)
- Problem exists – US, Europe interarea modes, oscillations in high-IBR systems (islands, AEMO, etc.)
- Novel IBR stability control strategies can be enabled for damping inter-area and local modes
- Improvements in WAMS and WADC systems (faster speed and better determinism)

Stability services by IBRs is part of many NREL research projects funded by DEO WETO, SETO, WPTO, OE, and many industry collaborations.

Examples of local mode oscillations measured in Colorado

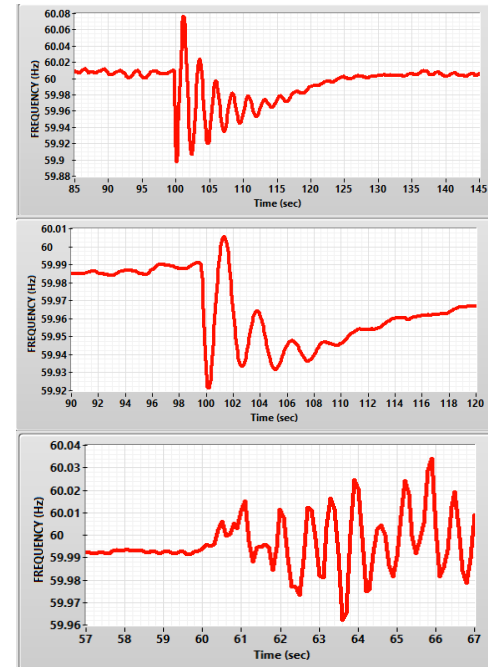

Measured frequency droop response of 300 MW PV plant

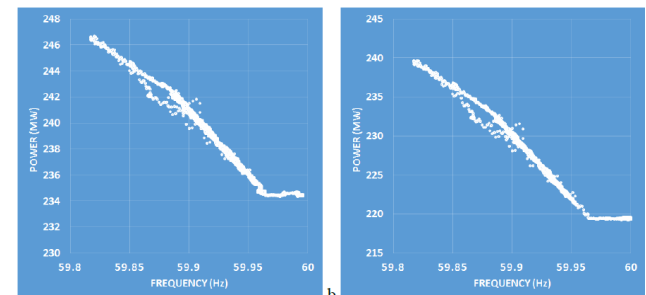

IBR Resources to provide damping: Examples of tests at NREL

1MW BESS

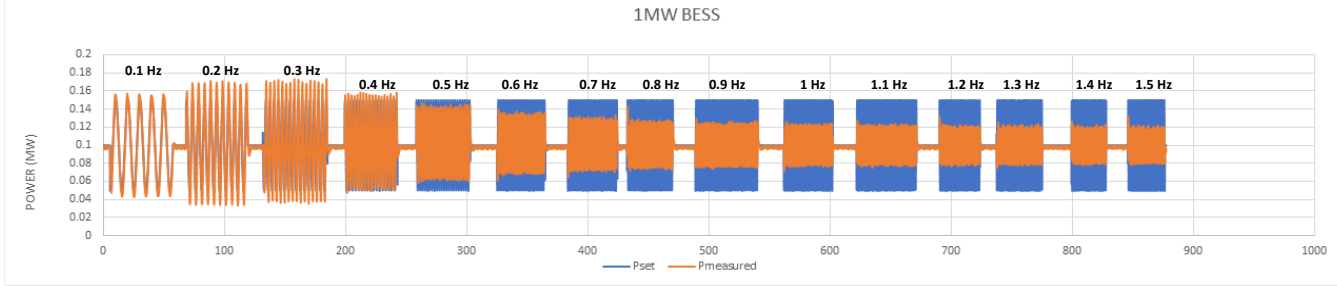

450 kW PV

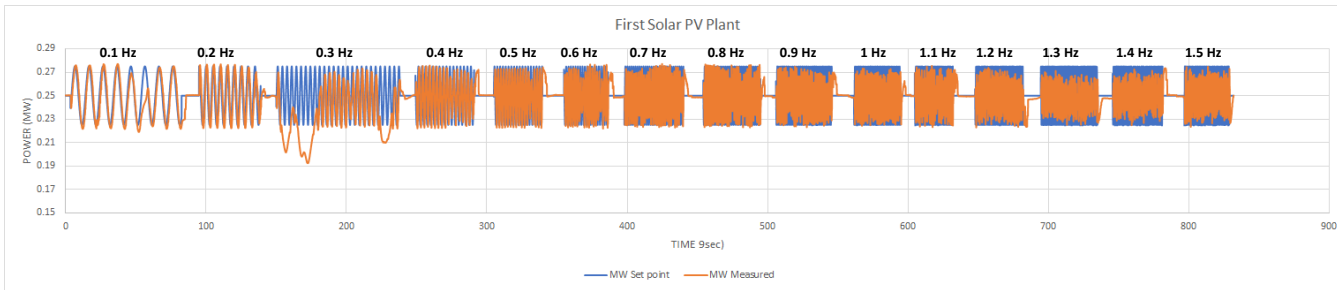

1.5 MW Wind

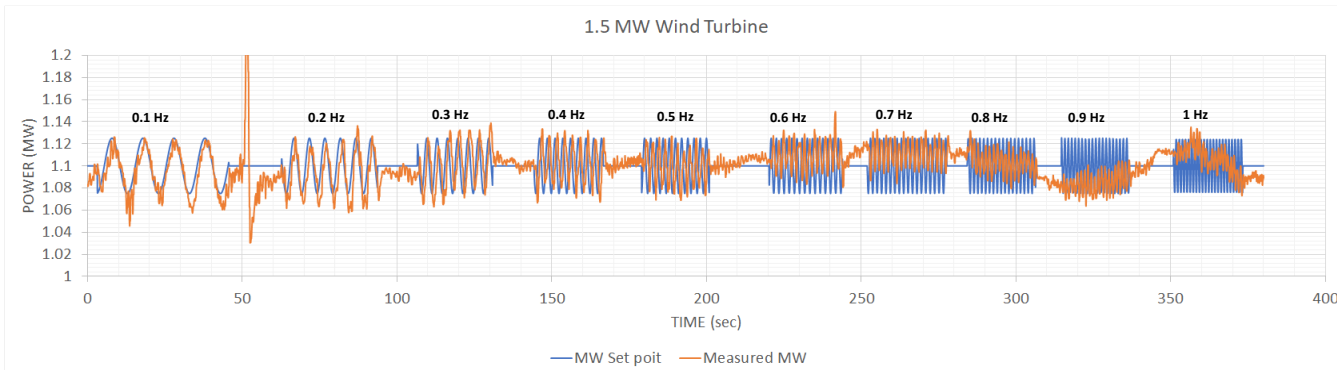

Testing of 1.5 MW Type 3 WTG for Power System Oscillations Damping Services

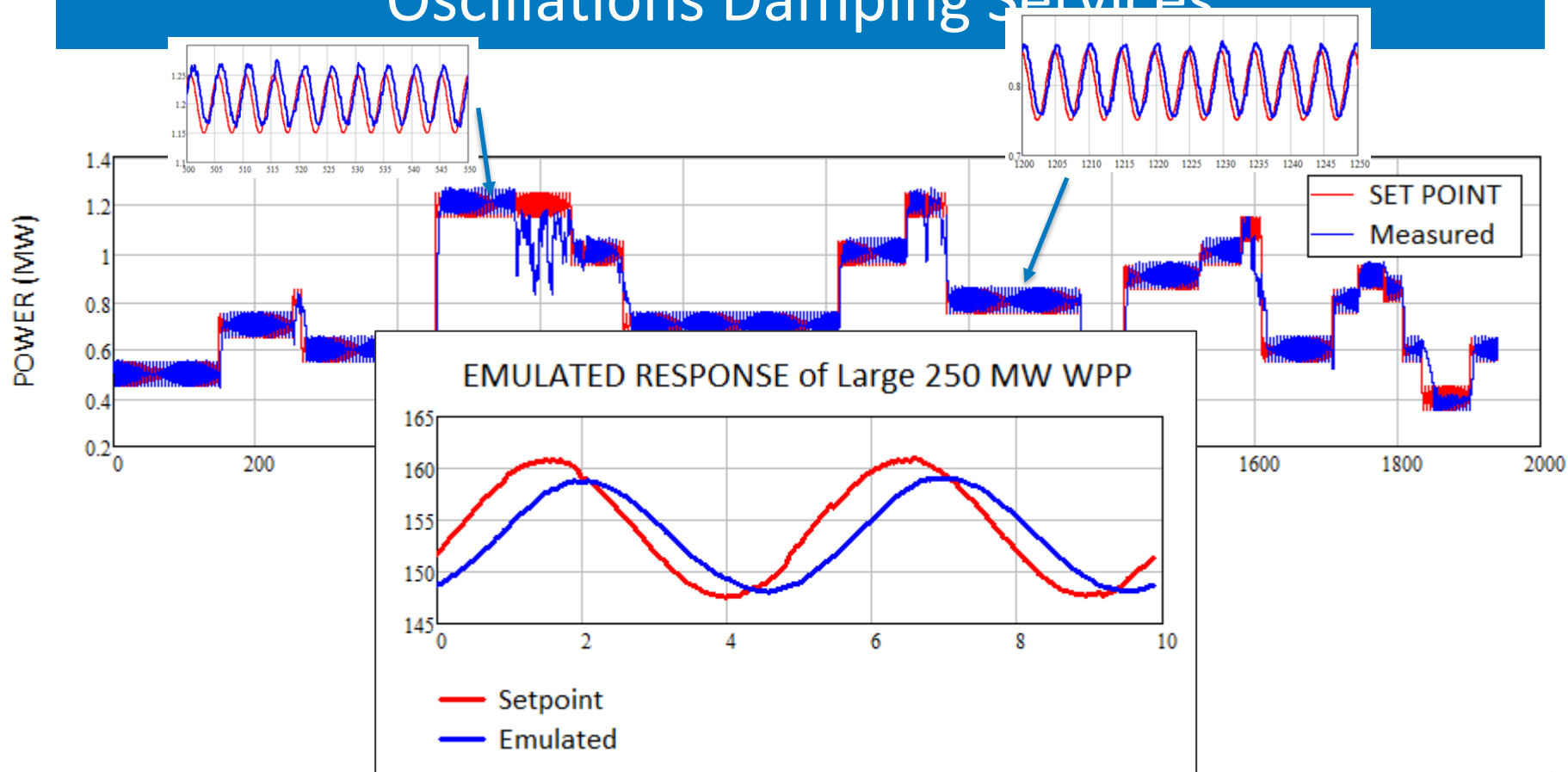

Ability of DFIG WTG to Provide Simultaneous Modulation of P and Q

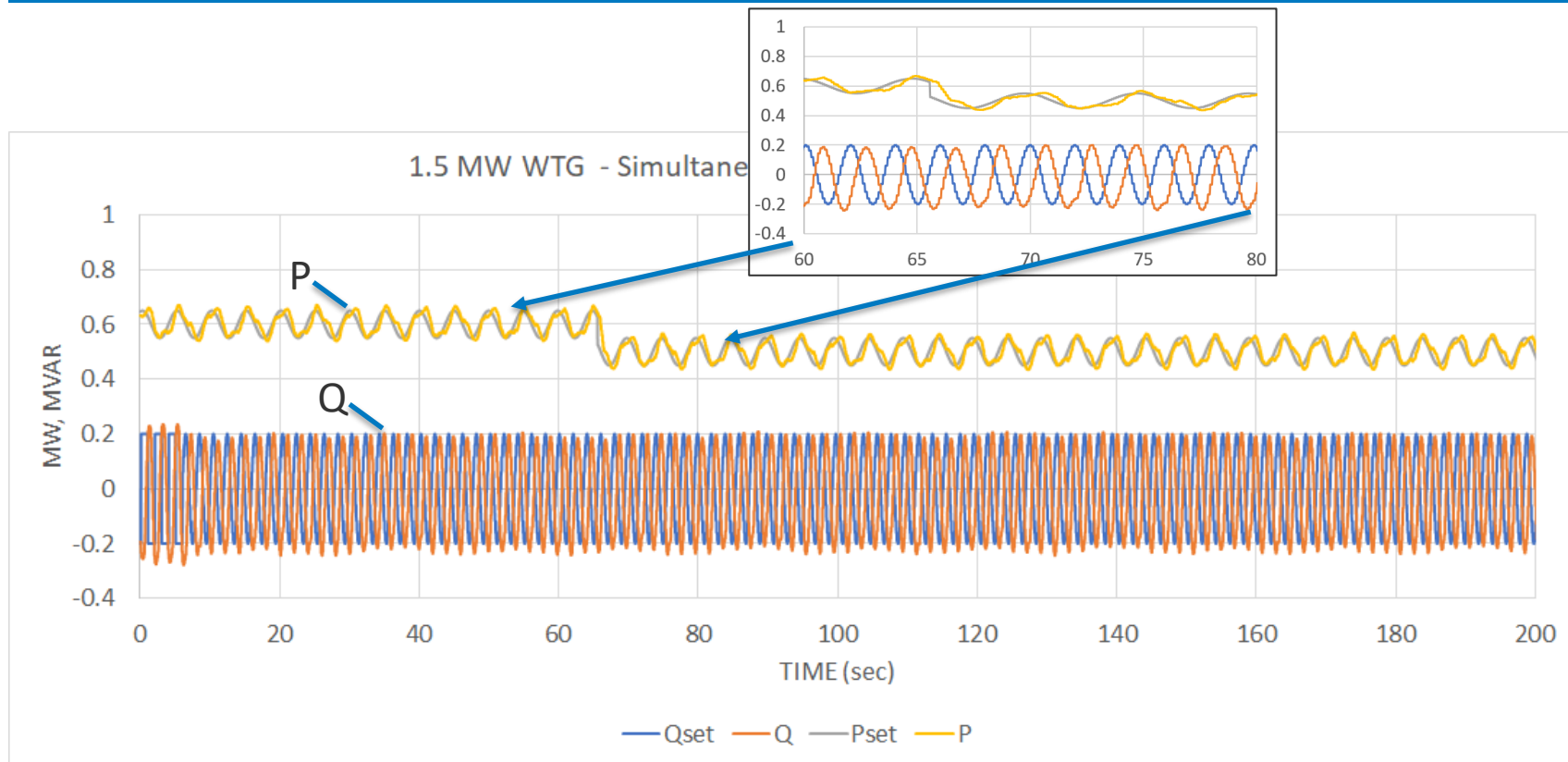

Controllable grid Interface

Power rating

- 7 MVA continuous
- 39 MVA short circuit capacity (for 2 sec)
- 4-wire, 13.2 kV

Possible test articles

- Types 1, 2, 3 and 4 wind turbines
- PV inverters, energy storage systems
- Conventional generators
- Combinations of technologies

Voltage control (no load THD <1%)

- Balanced and un-balanced voltage fault conditions (ZVRT and 140% HVRT) – independent voltage control for each phase on 13.2 kV terminals
- Response time – 1 millisecond (from full voltage to zero, or from zero back to full voltage)
- Long-term symmetrical voltage variations (+/- 10%) and voltage magnitude modulations (0-10 Hz) – SSR conditions
- Programmable impedance (strong and weak grids)
- Programmable distortions (lower harmonics 3, 5, 7)
- Impedance characterization of inverter-coupled generation
- Full STATCOM functionality

Frequency control

- Fast output frequency control (5 Hz/sec) within 45-65 Hz range
- 50/60 Hz operation
- Can simulate frequency conditions for any type of power system
- PHIL capable (coupled with RTDS)
- Test-bed for PMU-based wide-area stability controls
- **Test article impedance scan**

Controllable Grid Interface (CGI)

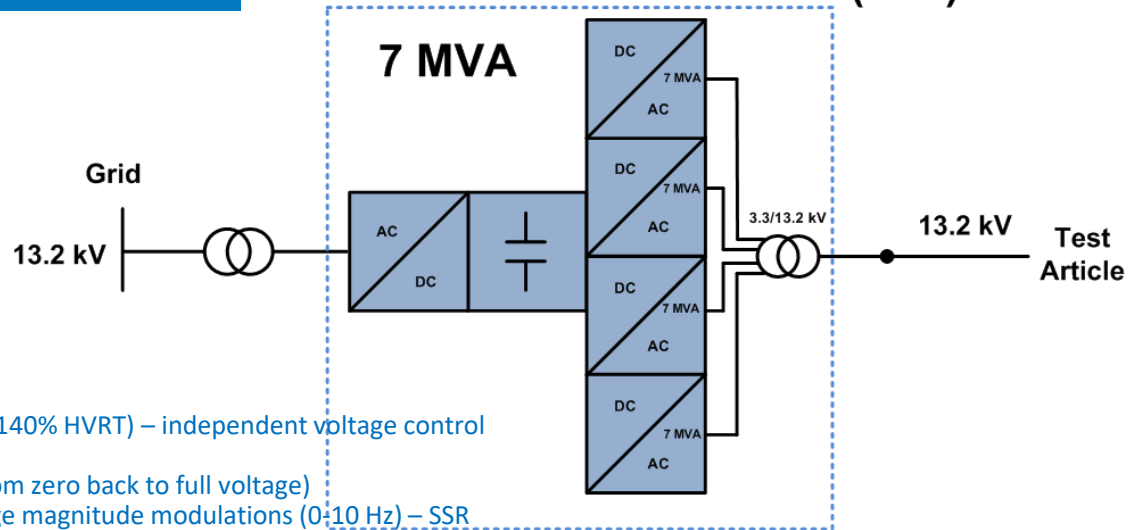

Less than 1 ms response time

Summary of CGI#2 Specifications

Power rating

- Continuous AC rating - 19.9 MVA at 13.2kV and 34.5 kV
- Overcurrent capability (x5.7 for 3 sec, x7.3 for 0.5 sec)
- 4-wire 13.2 kV or 35.4 kV taps
- Continuous operational AC voltage range: 0 - 40 kVAC
- Continuous DC rating – 10 MW at 5 kVDC

Possible test articles

- Types 1, 2, 3 and 4 wind turbines
- PV inverters, energy storage systems
- Conventional generators
- Combinations of technologies / hybrid systems
- Responsive loads

Voltage control (no load THD <1%)

- Balanced and unbalanced voltage fault conditions (ZVRT, LVRT and 140% HVRT) – independent voltage control for each phase on 13.2 kV and 34.5 kV terminals
- Response time – less than 1 millisecond (from full voltage to zero, or from zero back to full voltage)
- Programmable injection of positive, negative and zero sequence components
- Long-term symmetrical voltage variations (+/- 10%) and voltage magnitude modulations (0-10 Hz) – SSR conditions
- Programmable impedance (strong and weak grids, wide SCR range corresponding to a POI with up to 250 MVA of short circuit apparent power)
- Injection of controlled voltage distortions
- Wide-spectrum (0-2kHz) impedance characterization of inverter-coupled generation and loads
- All-quadrant reactive power capability characterization of any system

Frequency control

- Fast output frequency control (3 Hz/sec) within 45-65 Hz range
- 50/60 Hz operation
- Can simulate frequency conditions for any type of power system
- PHIL capable (can be coupled with RTDS)
- Coupled with PMU-based wide-area stability controls validation platform

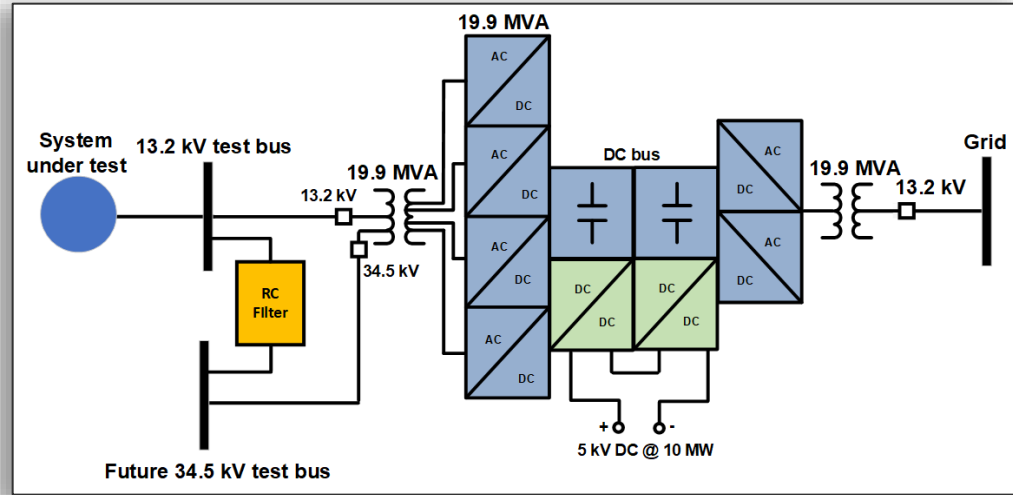

100 μ s response time

New features

- 5 kV MVDC grid simulator (PHIL capable)
- Voltage or current source operation
- Seamless transition between voltage and current source modes
- Emulation of full set of resiliency services:
 - Black start
 - Power system restoration schemes
 - Microgrids
- Flexible configurations are possible when combined with CGI#1:
 - Two independent experiments
 - Parallel operation
 - Back-to-back operation
 - Emulation of isolated, partially or fully grid-connected microgrids

Wide-Area Stability Controls Validation Platform

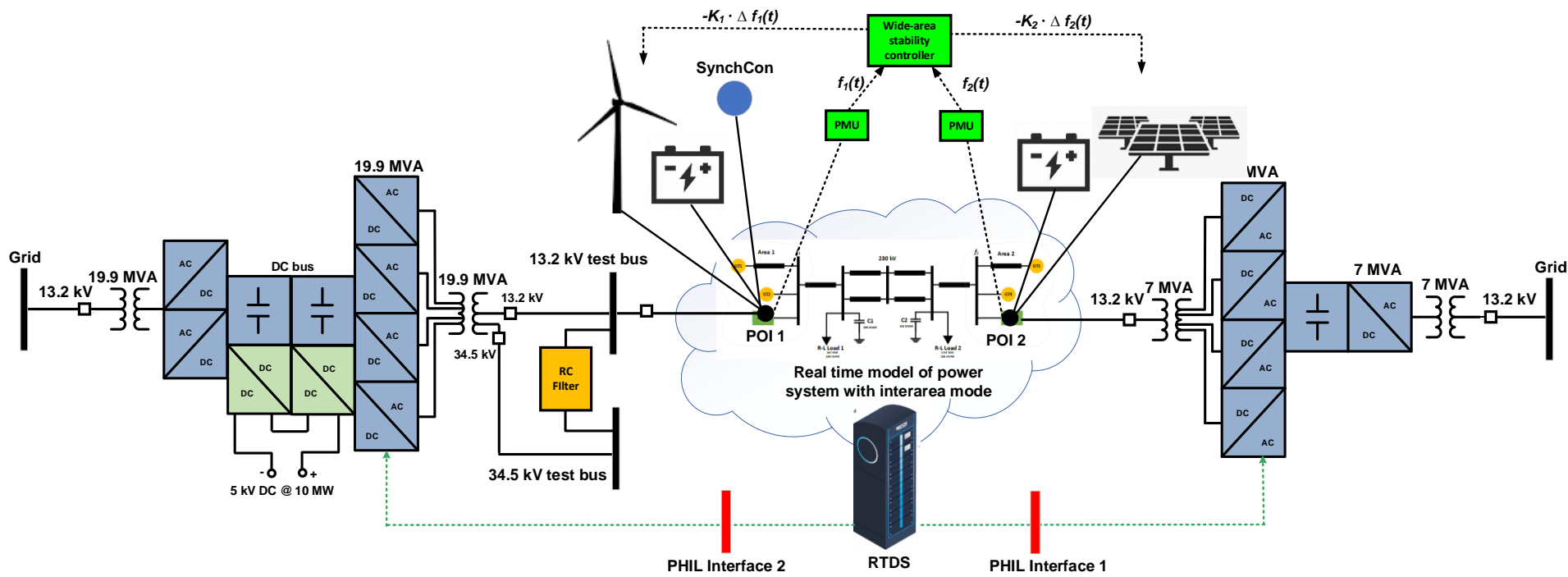

- Two-POI PHIL platform using real time model of a power system
- Multi-MW real IBRs (wind, PV, BESS), synchronous machine and loads coupled with real controllers, measurement units and communications

POD controls

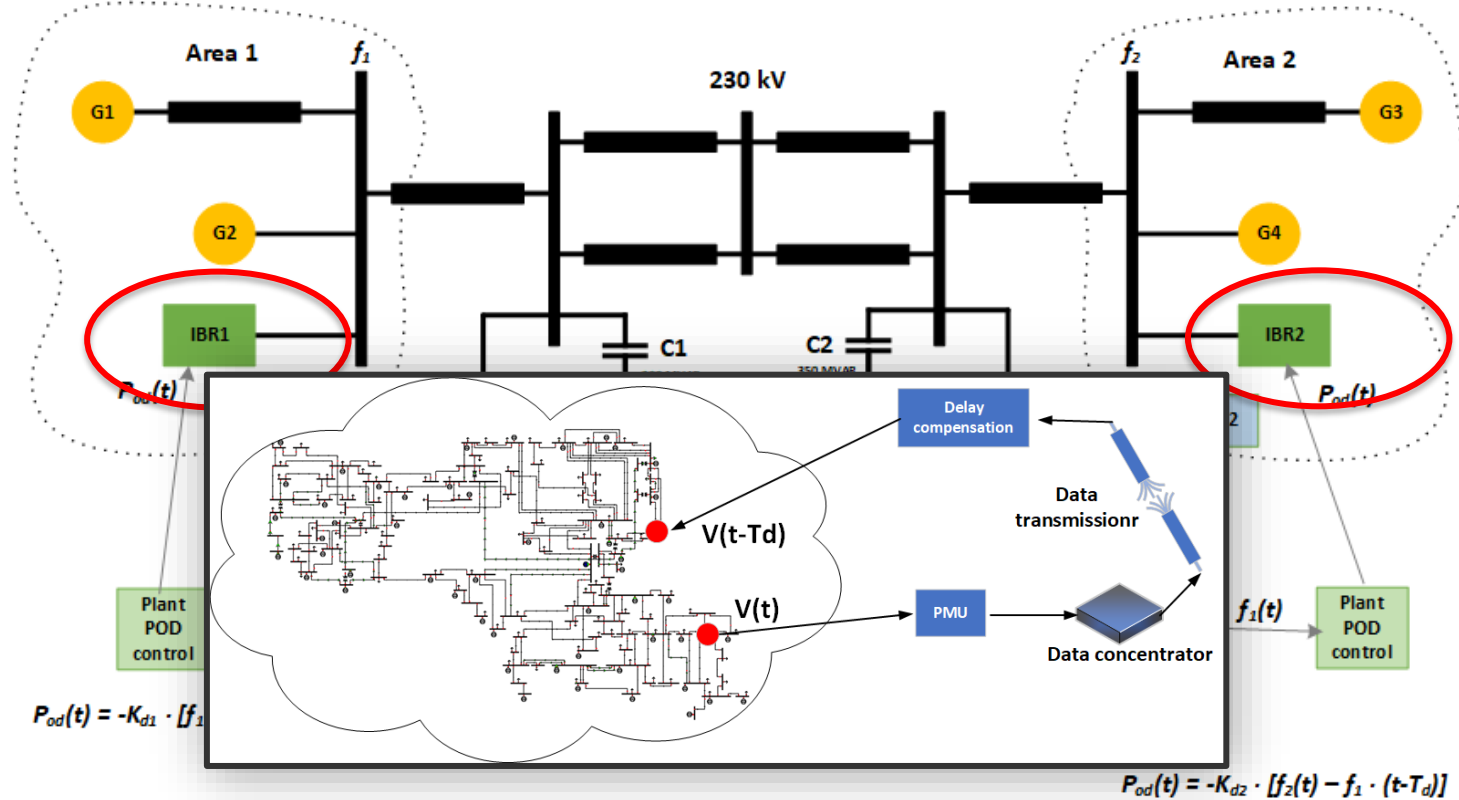

K_{d1} – damping gain (MW/mHz)
for area 1

$T_d = T_{d1} + T_{d2}$ – communication delay (ms)

K_{d2} – damping gain (MW/mHz)
for area 2

Active Power Damping Control Strategies – 0.7 Hz inter-area mode

1. Curtailed operation – headroom available

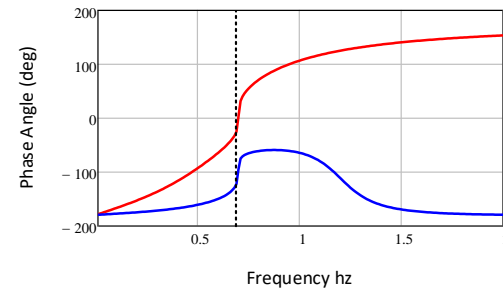
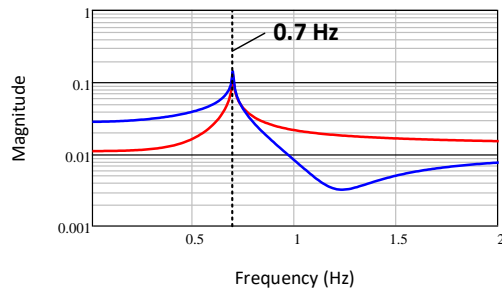
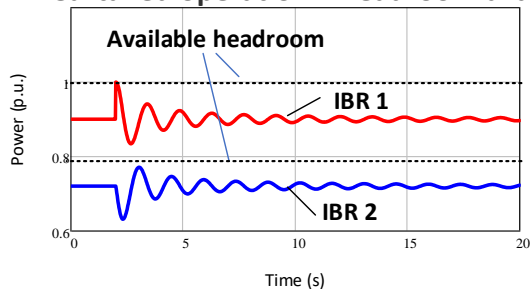

2. Max power operation – no headroom available

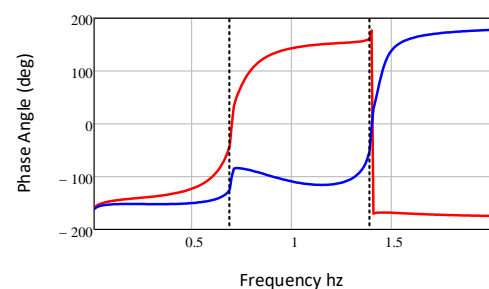
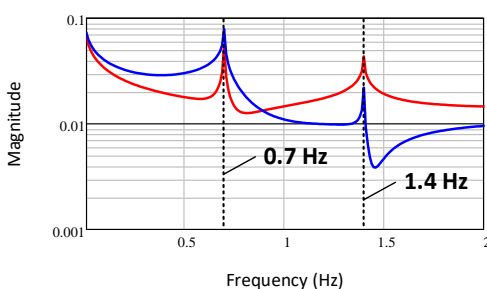
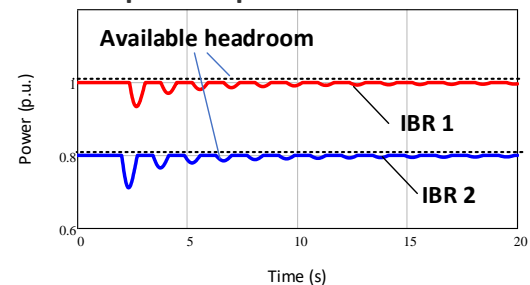

3. Temporary curtailment

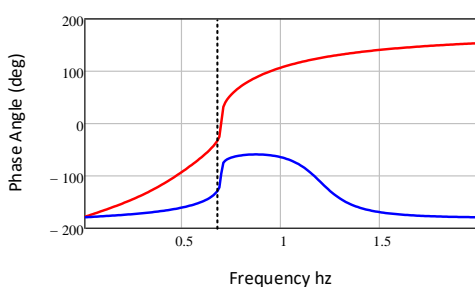
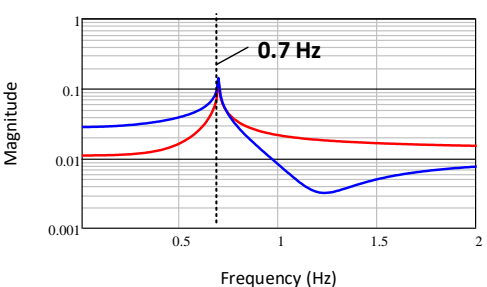
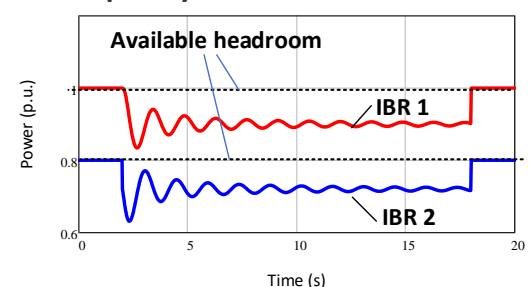

PV and BESS provide damping

1. No damping – system unstable

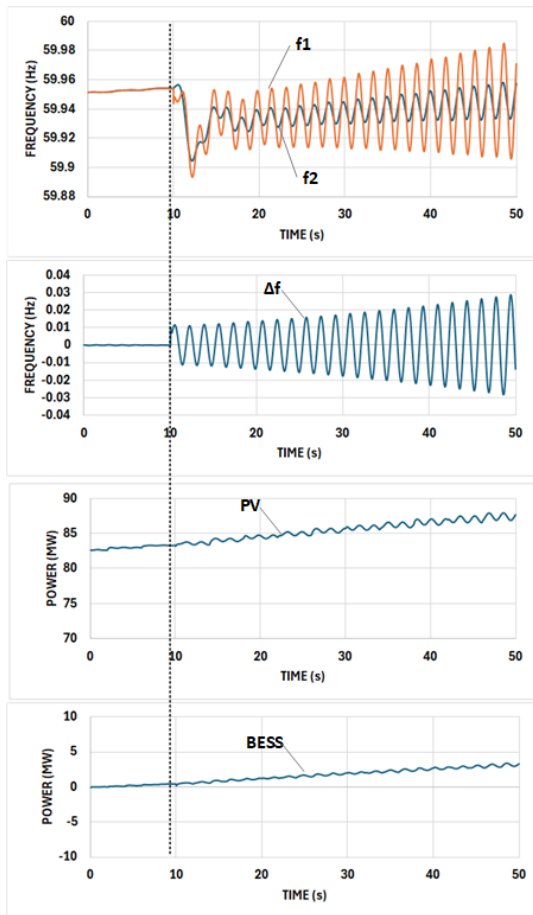

2. Damping – 300 ms delay

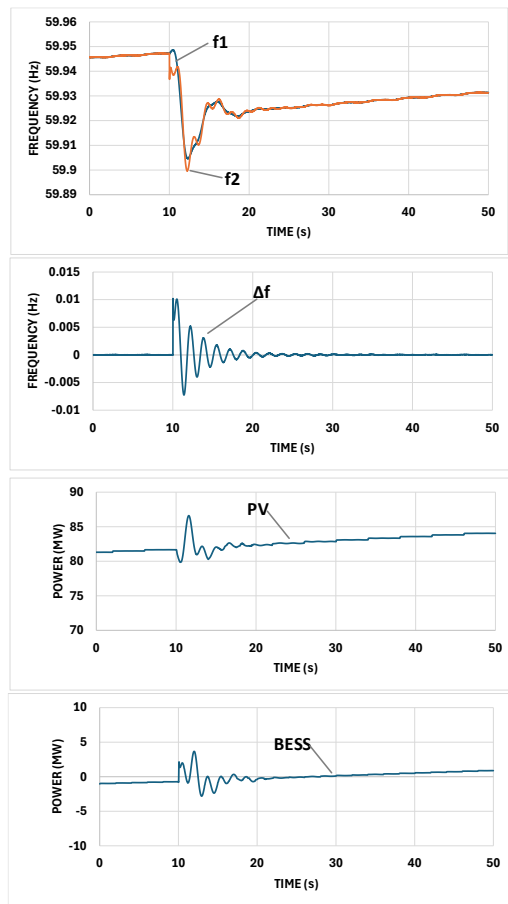

3. Damping – 900 ms delay

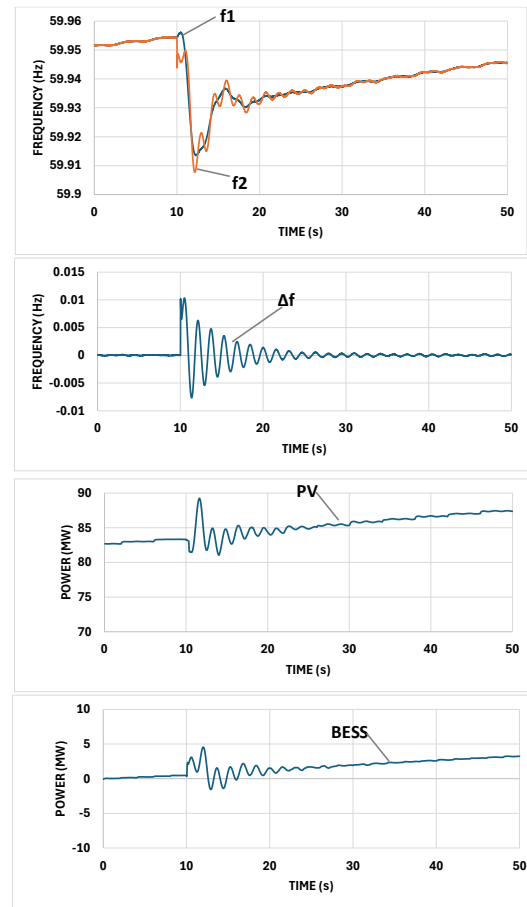

PV and BESS provide damping

4. One-area damping

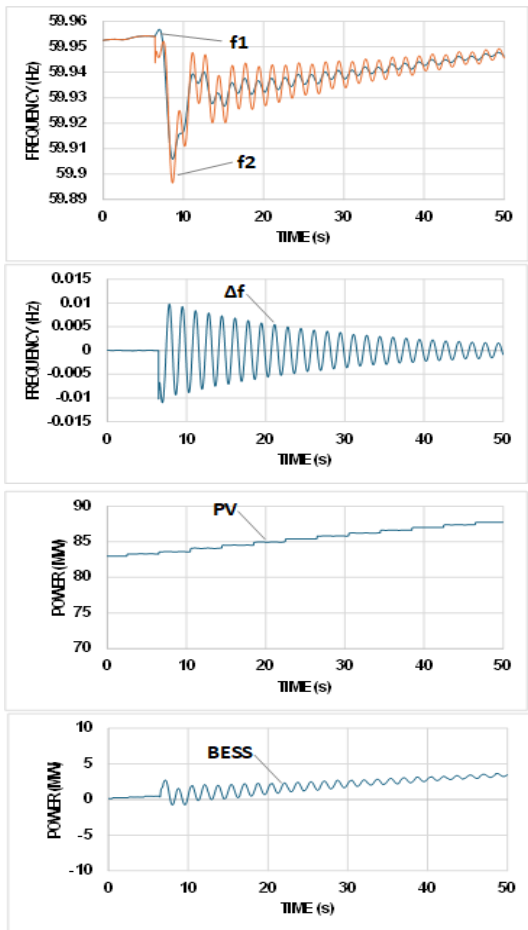

5. Local damping control

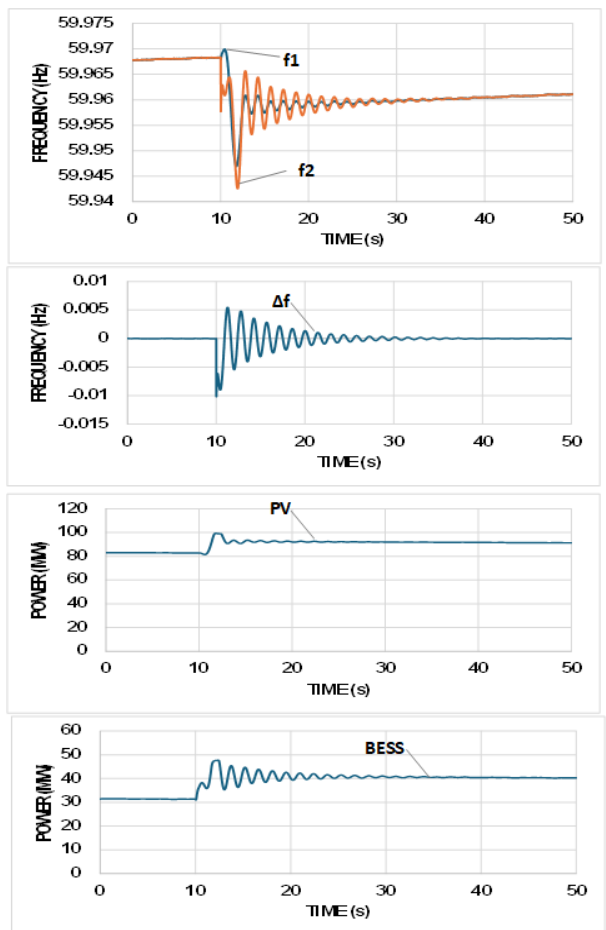

6. Damping without pre-curtailment

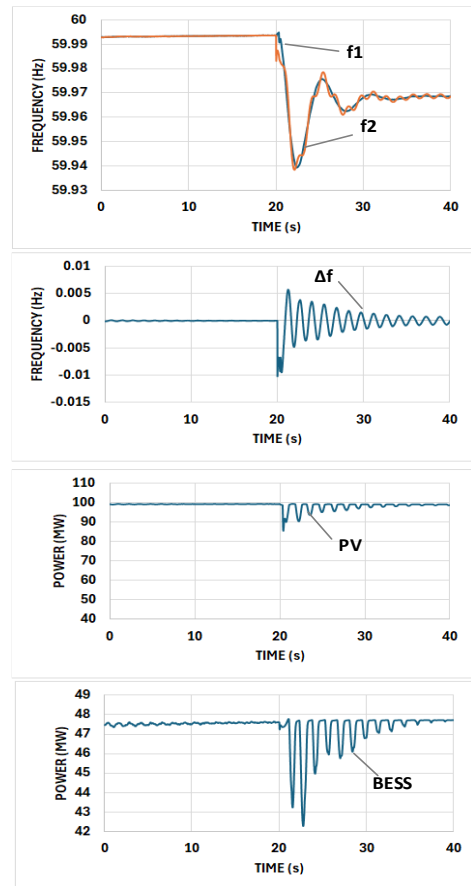

Instability triggered by voltage fault

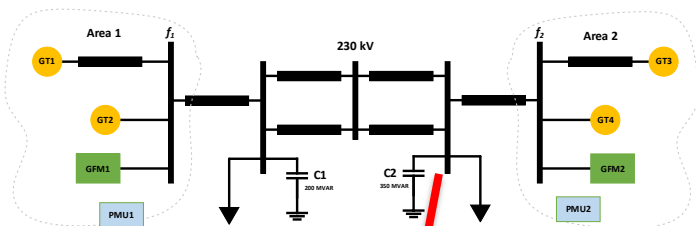

100 ms 3-phase voltage fault

300 ms delay

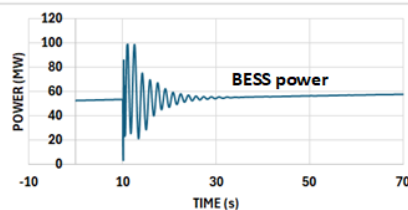
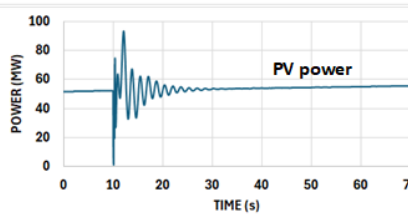
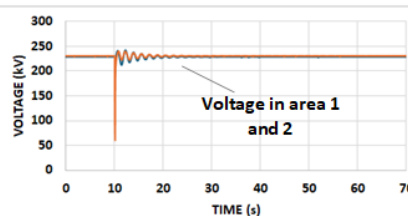
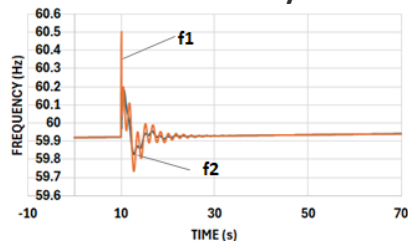

900 ms delay

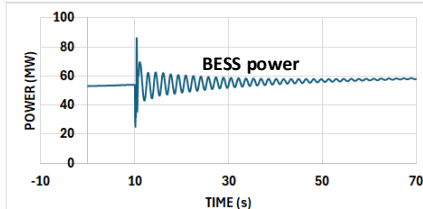
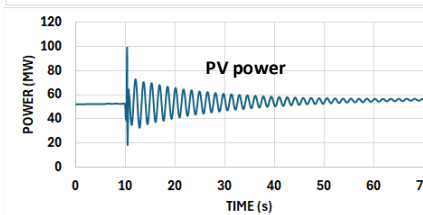
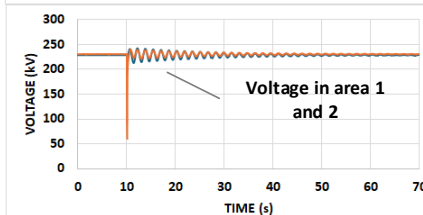
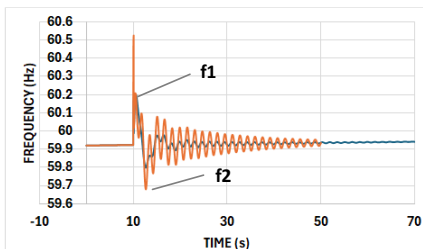

Damping by Wind and PV

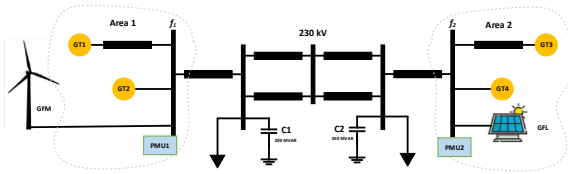

- GFM Type 3 wind turbine
- GFL PV plant

Advantages of GFM Type 3 GFM:

- High levels of SC current
- Immunity to SSR

GFM wind and PV provide damping

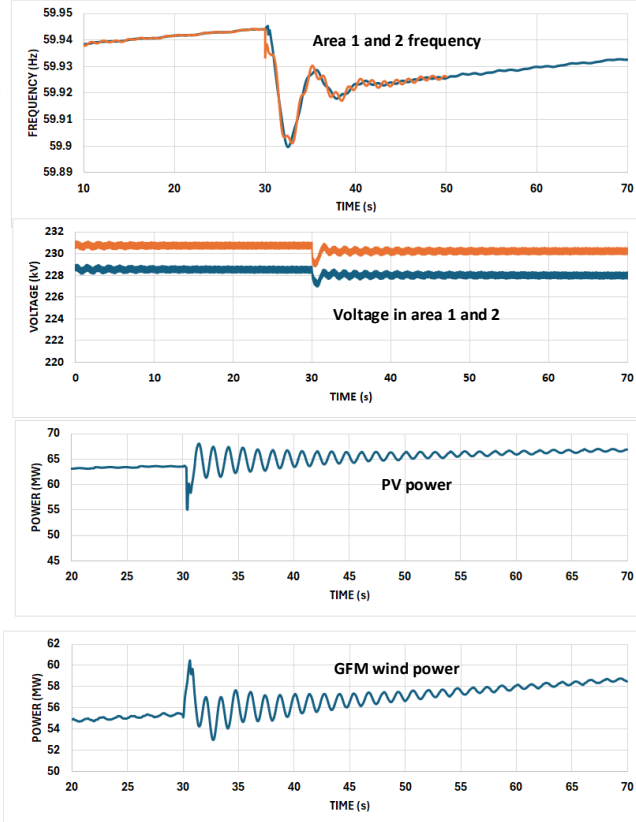

Only GFM provides damping

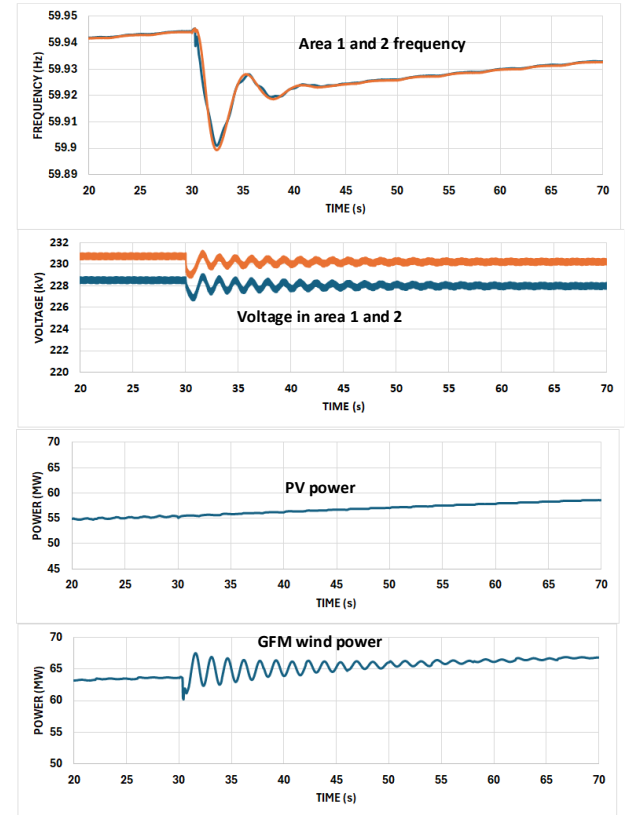

Synch Condensers to Provide POD Services

- On going research using NREL's 2.5 MVA synchronous machine
- NREL SC characterization experiment
- SC P and Q response to field voltage modulations



Lister Drive greener Grid park (Liverpool, UK).
ABB's synchronous condensers with flywheels.
Photo courtesy: Statkraft

- 2 x 67 MVAR
- 2 x 465 MWs
- 13.8 kV
- 275 kV tie with National Grid
- POD function implemented in ABB's Unitrol AVR platform at this site

Strong
grid

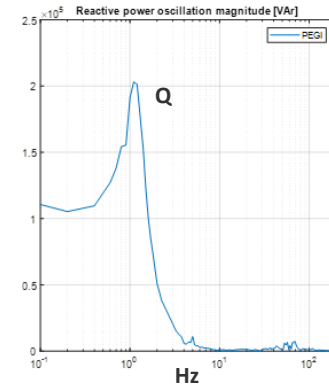
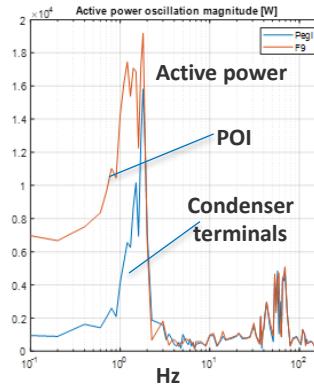

Weak
grid

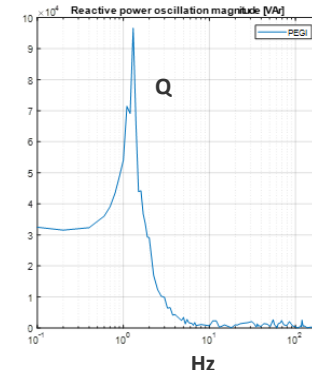
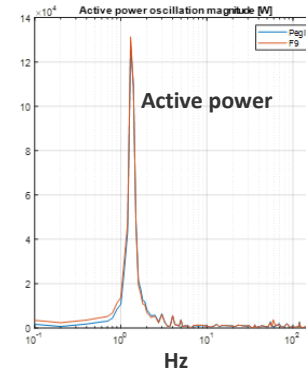

SSR Damping with IBRs

Spring mass model of thermal power plant

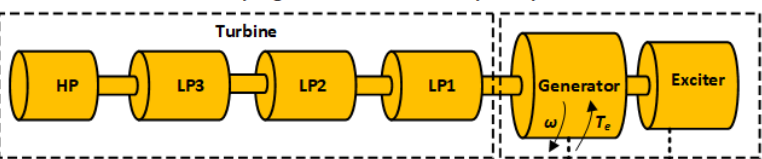

System with 17 Hz resonance

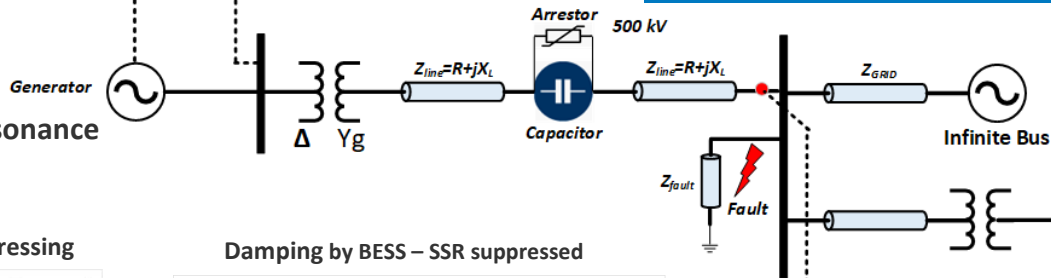

No damping by BESS – SSR progressing

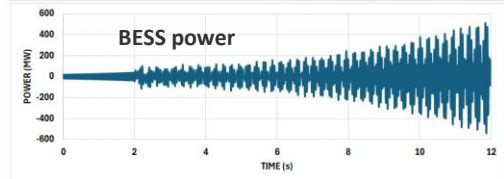
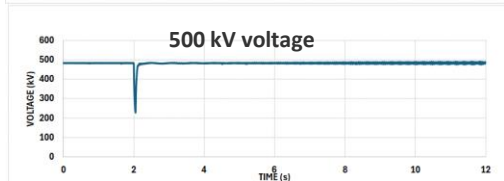
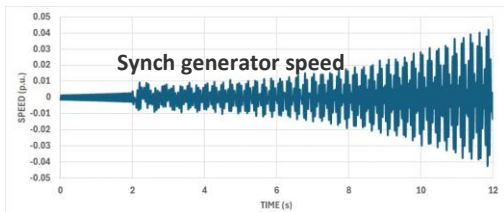

Damping by BESS – SSR suppressed

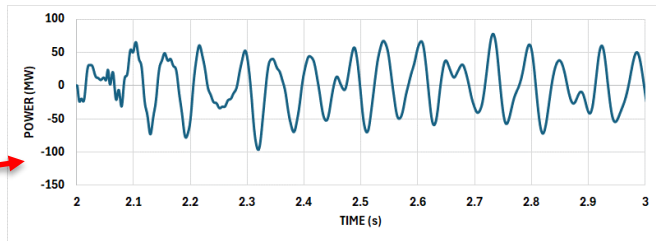
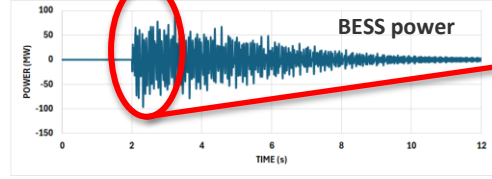
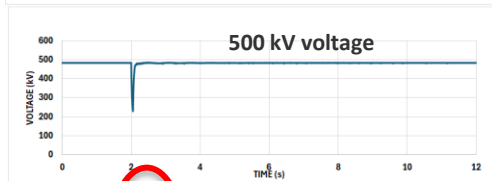
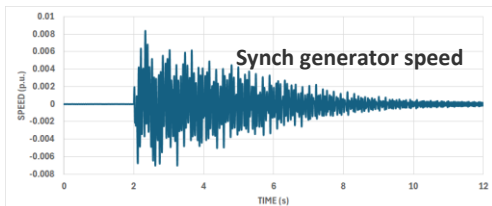

GFL BESS providing SSR damping control

Summary and Next Steps

- It was demonstrated that that IBRs can provide damping services with local and centralized controls
- Delay compensation technique can be used to compensate for comm latencies
- Local vs. centralized stability controls (PSS functionality vs. wide-area damping controller):
 - Which method is better, especially for low/zero inertia and weaker grids?
- Next steps: demonstrations of stability services in low/zero inertia grids (including inter-area oscillations, SSR, voltage instabilities, etc.)
- Role of GFM resources and synch condensers in wide-area stability



Thank you

www.nrel.gov

vahan.gevorgian@nrel.gov

This work was authored by the National Renewable Energy Laboratory, operated by Alliance for Sustainable Energy, LLC, for the U.S. Department of Energy (DOE) under Contract No. DE-AC36-08GO28308. Funding provided by U.S. Department of Energy Office of Energy Efficiency and Renewable Energy Wind Energy Technologies Office, Solar Energy Technology Office, and Office of Electricity. The views expressed in the article do not necessarily represent the views of the DOE or the U.S. Government. The U.S. Government retains and the publisher, by accepting the article for publication, acknowledges that the U.S. Government retains a nonexclusive, paid-up, irrevocable, worldwide license to publish or reproduce the published form of this work, or allow others to do so, for U.S. Government purposes.

Photo from iStock-627281636

