

Background on Flexibility Products and Alternative Options, Implementation Details and Evolution of Flexibility

Tutorial: Evolution and Effectiveness of Flexibility Products in Markets and Operations

Nikita Singhal
Technical Leader

ESIG Fall Technical Workshop
October 24, 2022



Introduction

■ Challenges faced by the bulk power systems

- Evolving system flexibility and operational reliability needs: Dramatic changes in the resource mix due to the increased reliance on variable energy resources that results in the net load having a different trend each day, and each hour
- Insufficient ramp capability that is often being committed and dispatched to address real-time system net load forecasts due to uncertainty around ramping needs within security-constrained economic dispatch (SCED) look-ahead periods
- Increased imbalance between day-ahead and real-time markets: Consistent reliance on out-of-market (OOM) actions (frequency and magnitude) to procure additional capacity for uncertainty and ramping; market price divergence due to OOM actions
- Price spikes and reliability concerns due to insufficient ramp capability
- Requirement determined to satisfy the expected ramp (variability) and some confidence level of unexpected ramps

Where can variability and uncertainty (imbalances) occur?

- Within an interval: intra-interval variability
- Between two intervals: inter-interval variability
- Between two scheduling cycles/time-frames: between the day-ahead and real-time timeframes
 - Depending up on the physical characteristics of the resource mix, e.g., start-up time and minimum run time, it may be necessary to introduce additional scheduling cycles between day-ahead and real-time or before the day-ahead to secure additional ramping capability through commitments
- Beyond an optimization horizon:
 - real-time economic dispatch look-ahead periods
- Uncertain scenarios may realize in both day-ahead and real-time

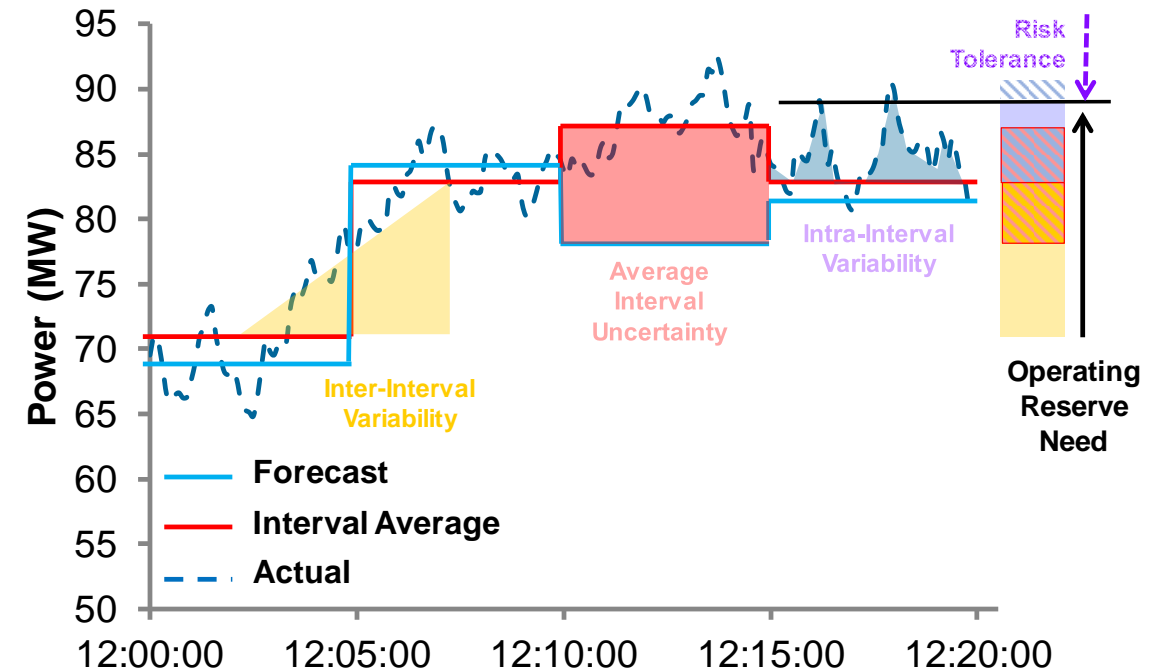

ISO/RTO Flexibility Products

- Short-term flexibility reserve: CAISO (flexible ramping product), MISO (ramp capability product), SPP (ramp product)
- Longer-term: CAISO (imbalance reserves), SPP (uncertainty product), ERCOT (proposed uncertainty product)
- Possible adjustments
 - Requirement setting
 - Single requirement vs. multi-step
 - Demand curve or shortage setting
 - Response time of product
 - Direction of product (up and/or down)
 - Online only vs. offline allowed
 - Which scheduling processes held, and any changes between them
 - Availability bids vs. lost-opportunity cost only
 - Cascading price effect with other products
 - Post-deployment deliverability constraints (zonal, nodal)

Mechanisms to Ensure Flexibility Provided Reliably and Cost-Effectively

Address greater uncertainty in day-ahead time frame

Day-ahead uncertainty reserve product

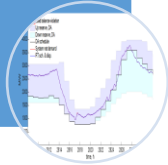

Value reserve above minimum requirements

Operating Reserve Demand Curve

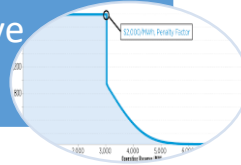

Price opportunity costs of ramp

Multi-interval settlement

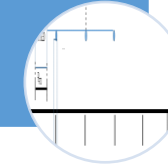

Represent uncertainty explicitly

Stochastic multi-scenario market scheduling

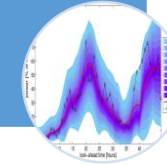

Make sure flexibility is built

Forward Flexible Capacity Attribute Procurement

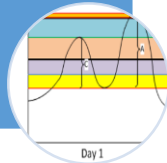

Let demand provide flexibility inherently

Real-time demand pricing and DR



Flatten the curve with correct incentives

Energy Storage



Reduce uncertainty directly

Enhanced Forecasting



Operational Flexibility and Reliability in Markets

- Forecasting dynamic reserve is similar to forecasting load or VER output, and can be used to improve reliability and economic efficiency
- Extended downward sloping ORDCs beyond the minimum contingency reserve requirement can be beneficial if designed adequately; so can flexibility reserve;
 - **These two flexibility mechanisms may be identical under different names; however, the current implementation of both may lead to different outcomes**
- Reserve does not only improve reliability, it can also reduce operating costs
- Designing and introducing products may demonstrate benefits in studies; however, the design (including stakeholder debate), implementation, and administration can also be costly, including performance impacts

Reserve forecasting: Uncertainty is not constant through time

- New reserve products are being introduced across different horizons
- Probability and magnitude of forecast errors decrease as horizon reduces
- Most reserve products are being designed with constant requirements from day-ahead to real-time
- Reserve needs change across time, e.g., different night v/s day
- Reserve needs change through time, e.g., need for hour 10 a day ahead is different from the need for hour 10 an hour ahead
- Price formation a key question on designing products with issues such as multi-settlement, product substitution, shortage pricing requiring clarity

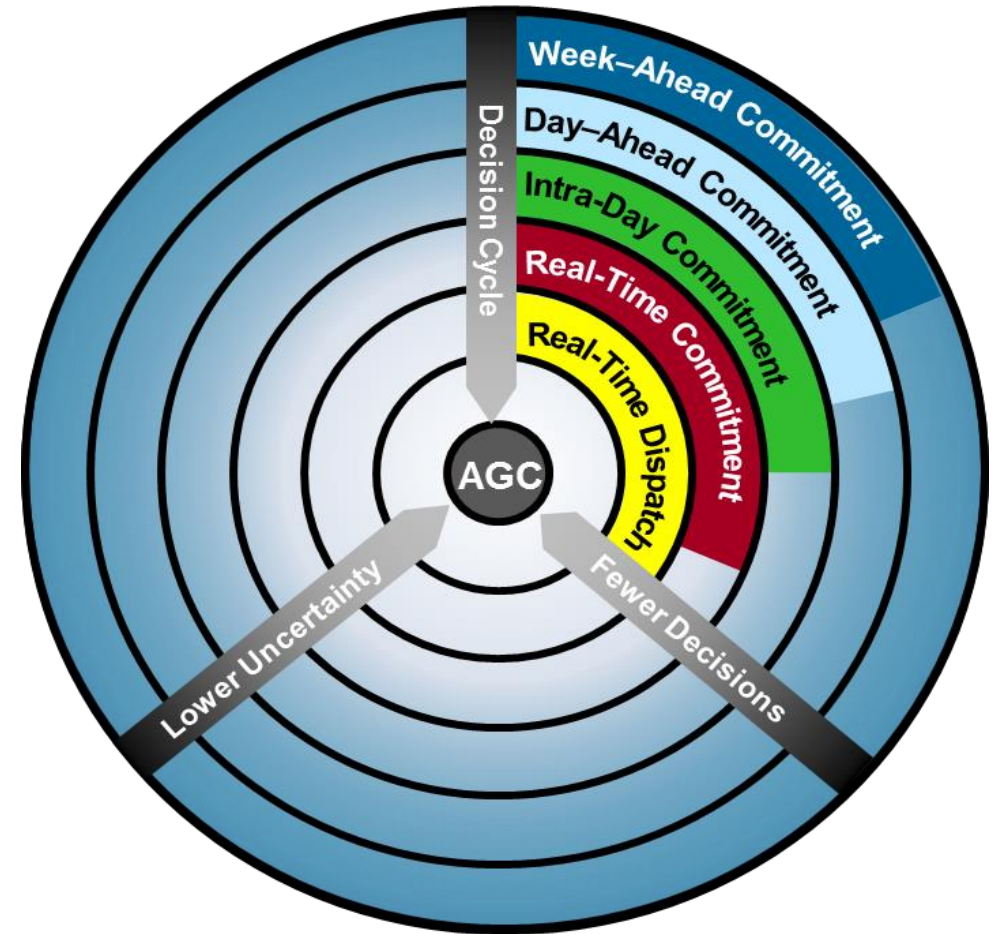

Reserve types should be defined by scheduling process

- Reserve products may be better defined by the decision processes compared to response times (e.g., day-ahead reserve released in hour-ahead), this can align the reserve holding to the decisions that can be made according to the scheduling process
- The flexibility response time need (e.g., 10-min vs. 30-min vs. hour ramp product) is a continuum, but the most critical time horizon can be determined by 1) the largest need or inflection point 2) where lack of associated flexibility may exist

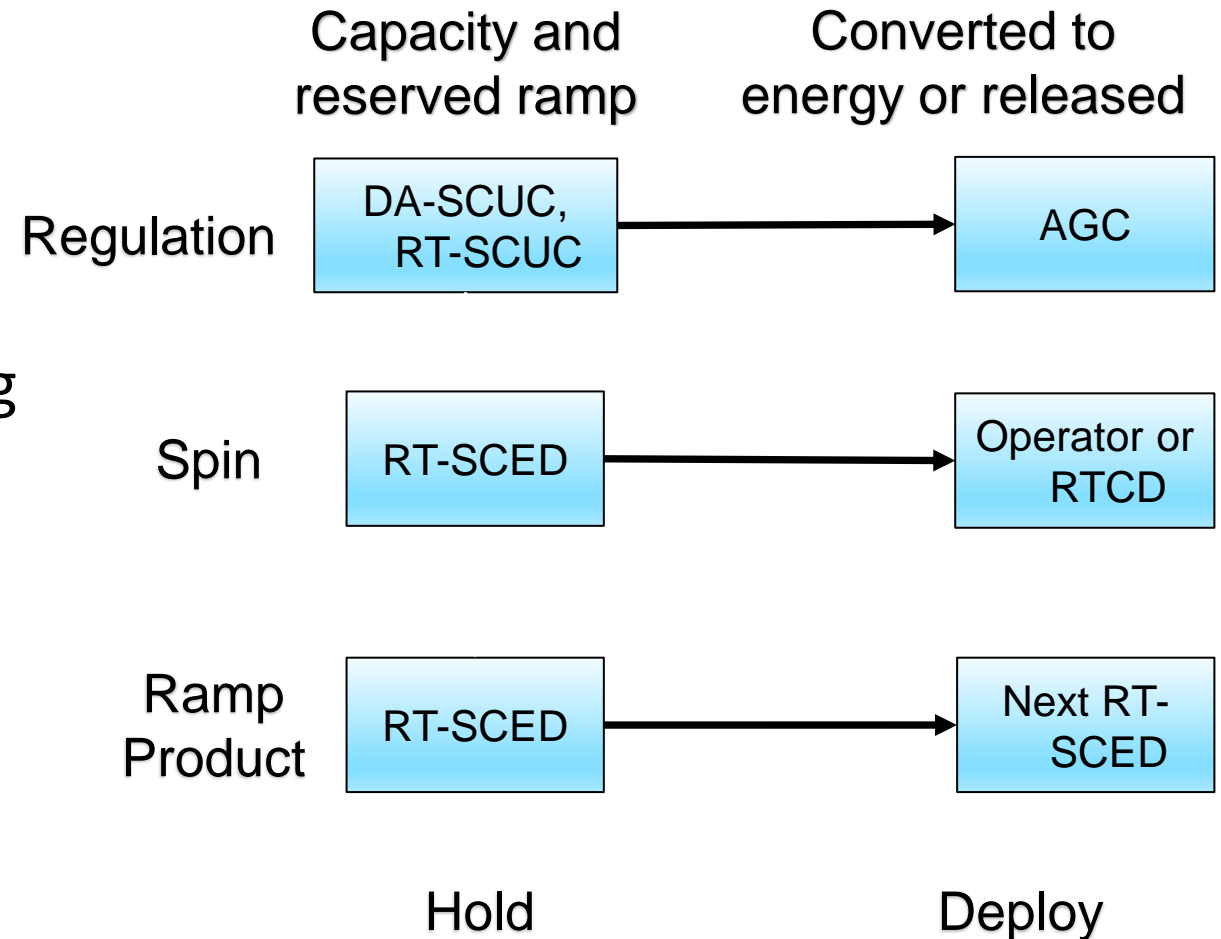

Meeting Operating Reserve Needs Implicitly Through Advanced Scheduling Applications

- Implicit ways of meeting operating reserve such as multi-period dispatch and shorter market intervals have efficiency gains but require thought regarding incentives
- Multi-period real-time models may have greater benefit in the future with more storage penetration; Pricing needs to be improved due to complications of only using the binding interval for settlement

Three Central Needs for Reserve	Explicit Reserve Requirement	Implicitly Scheduled Operating Reserve
1. Variability occurring within the interval	Reserve Requirements (e.g., regulation reserve)	High resolution scheduling intervals
2. Variability anticipated beyond the interval	Reserve Requirements (e.g., flexible ramping reserve)	Time-coupled multi-period dispatch w/ longer look-ahead horizons
3. Uncertainty of future conditions	Reserve Requirements (e.g., contingency reserve)	Stochastic or robust unit commitment and dispatch meeting multiple scenarios

- **Explicit reserve:** Met through reserve requirement constraint
- **Implicit reserve:** Met through a scheduling procedure that inherently schedules reserve

Operational Flexibility and Reliability in Markets

- Because day-ahead forecasts by the ISO are only used in the RUC processes, there may be limited benefits from more advanced forecasting techniques in this time frame
- The price of ancillary services under zero-fuel cost futures is complex and unclear. The interval lost opportunity cost when energy price is zero may also be zero. Non-convex pricing, inter-temporal opportunity costs, and shortage pricing design can all impact ancillary service prices in the future

Considerations for Future System Scenarios

Does this product (e.g., “x-minute”) still make sense and provide value on this future resource mix and scenario?

Given the formulation, is this new proposed product redundant with an existing product?

How does this emerging technology provide this flexibility service differently than existing technologies?

Will ancillary services be a substantial revenue source on future systems?

This new mechanism looks like it can enhance reliability and improve economic efficiency, but will it provide the right incentives for resources to follow?

Does this new proposed software enhancement make this exogenous reserve product obsolete?

Are we setting the requirements for this product based on what they are actually used for?

Are we allocating this product in appropriate locations?



EPRI 50th
ANNIVERSARY



Appendix

Reserve for Cost Reduction

	Variable Fuel Cost	Min Gen	Capacity	Started in RT?
G1	20\$/MWh	25 MW	100 MW	No
G2	30\$/MWh	25 MW	100 MW	No
G3	80\$/MWh	5 MW	100 MW	Yes

Load / Spin Reserve	DA	RT
Scenario 1	100 / 0	125 / 0

Scenario 1	DA	RT	Scenario 2	I1	I2
G1	100	100	G1 (Sched/Spin)	75/25	100
G2	0	0	G2 (Sched/Spin)	25/0	25
G3	0	25	G3 (Sched/Spin)	0/0	0
Cost (\$)	2,000	4,000	Cost (\$)	2,250	2,750

Not only does smart reserve requirements improve reliability, it also can reduce costs