



Grid Forming Inverter-Based Resources

Applications and Requirement discussion- BESS, Wind and Solar

Oct 13, 2021

Sebastian Achilles

sebastian.achilles@ge.com

GE Energy Consulting

Includes work @ GE Energy Consulting from:
Dustin Howard, Einar Larsen and Shruti Rao



Outline

- Low System Strength – Relevance to GFM
- How higher IBR penetration of scenarios affect SCR index and fault behavior evaluation

Aspects of low-system-strength challenges

Power Transfer Challenges

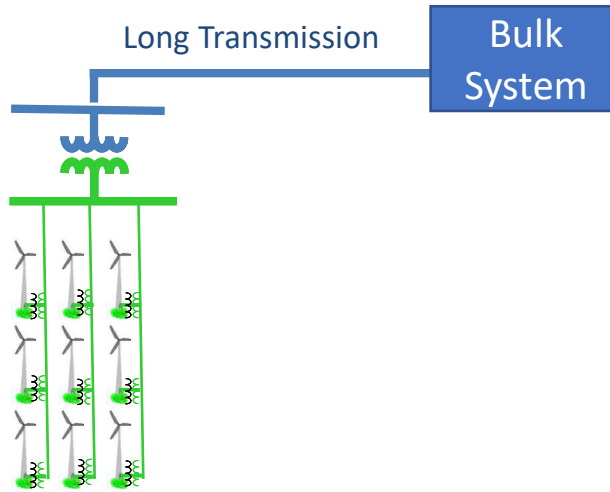

- Remote IBR plant or clusters
- Main challenges related to fault behavior and recovery during N-1 or weaker
- Frequent challenge in current and past projects or systems
- Mature GFL IBR design processes and controls

High IBR Penetration Challenges

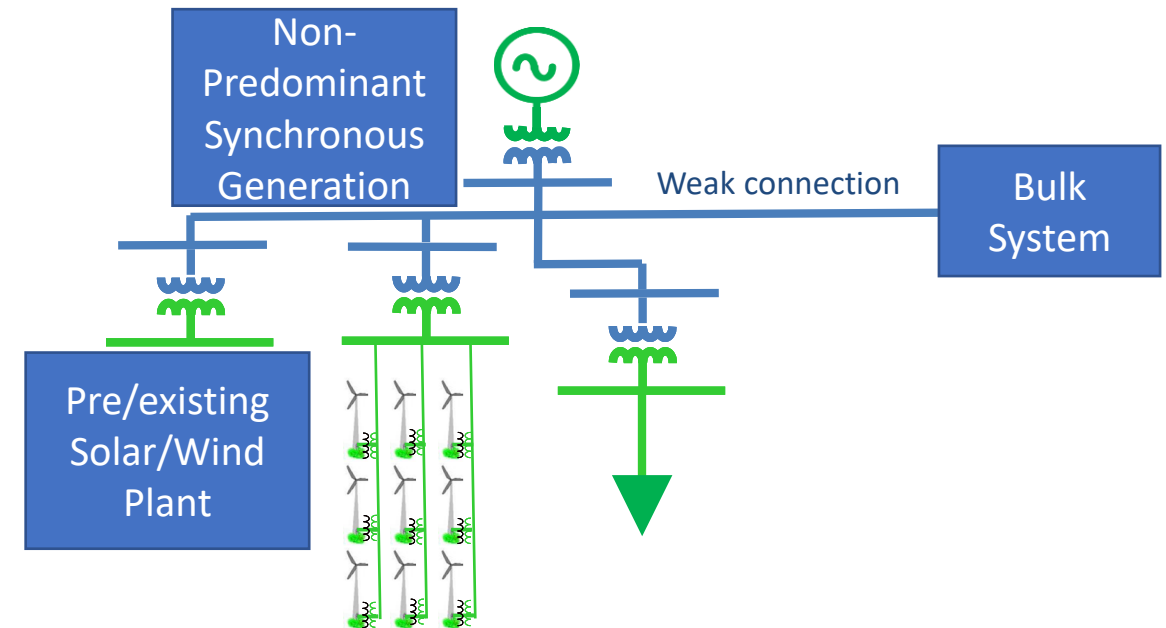

- Relevant in the context of de-carbonization of electricity
- Less frequent in current and past projects
- Transferring power over long electrical distance is **not** necessarily the challenge
- **Instability risks of GFL inner loops or interactions**
- **Larger ROCOF and Angle fluctuations**
- System operation and restoration

What problem are we trying to solve with GFM?

Low-system-strength challenges and SCR

Power Transfer Challenges (PTC)

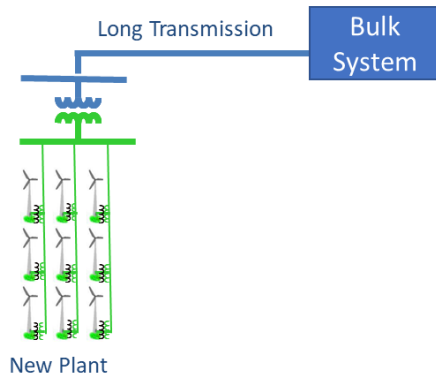

High IBR Penetration Challenges (HPC)

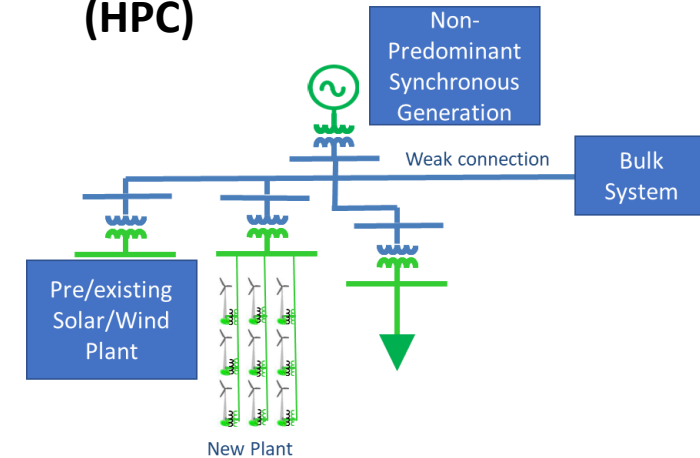

Simple conceptual equivalents considering power flow with respect to source of system strength related mostly to **steady state, fault and recovery performance**

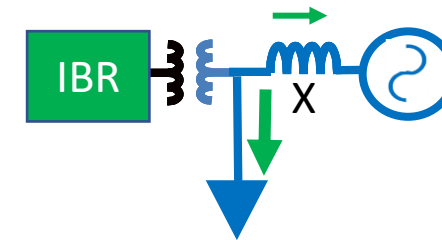
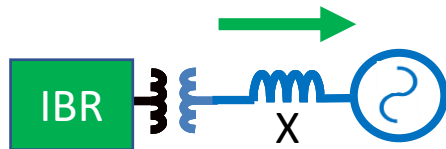

For example, if in both circuits $SCR = 0.5$, $X = 2pu$

- PTC equivalent does not have a feasible steady state operating condition
- HPC, if the load is $1pu$, there is a feasible steady state operating condition. If the IBR controls are small signal stable, an IBR system may operate stably

Same SCR value has a different interpretation in these circuits

System strength challenges and GFM/GFL performance expectations

Power Transfer Challenges (PTC)

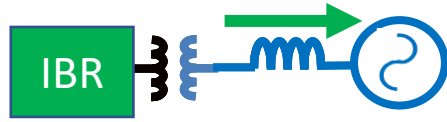

High IBR Penetration Challenges (HIPC)

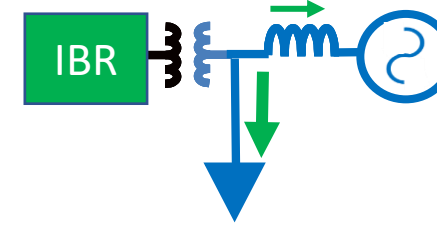

Load Power [pu] (1)	SCR (2)	GFL (3)	GFM	Challenge
0	1.5+	✓	✓	
0	1.0 to 1.5	Could work	Could work	PTC
0	<1.0	✗ 🍎	✗	PTC
0.5	0.75+	✓	✓	
0.5	0.5 – 0.75	Could work	Could work	PTC and HIPC
0.5	<0.5	✗	✗	PTC and HIPC
1	<0.2	✗ (4)	✓ 🍌	HIPC

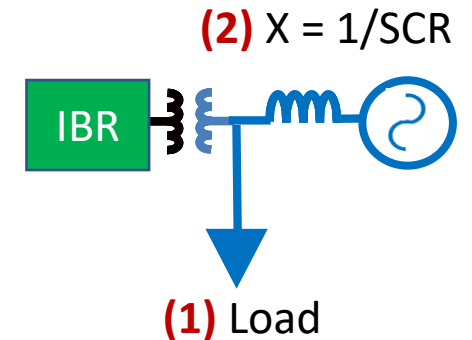

(3) Advance commercially available GFL IBR technology

(4) May work in some conditions

Comparisons of apples 🍎 with bananas 🍌 are not recommended
 This assessment does not evaluate all important HPC performance aspects

System strength challenges and GFM/GFL performance expectations

Other performance associated with High IBR Penetration Challenges

- Voltage angle jump response expectations:
 - Requirements related to tolerating voltage angle jumps without tripping – GFL and GFM
 - Requirements to “oppose” voltage angle changes by injecting or absorbing active power **very quickly** after event.
 - GFM is intended to do this-within the limitations of equipment
 - GFL would be expected to have no significant response or potentially a delayed response if specifically designed for it
- Fast rate of change of frequency (ROCOF)
 - Requirements related to tolerating ROCOF events without tripping – GFL and GFM
 - Requirements to “oppose” ROCOF events by injecting or absorbing active power **with a mitigating effect similar to synchronous machines.**
 - GFM is intended to do this-within the limitations of equipment
 - GFL would be expected to have no significant response or potentially a delayed response if specifically designed for it
- Comments on Voltage Control
 - Low system strength – Voltage Control usually more adequate than Reactive Power Control
 - Voltage control at plant level
 - GFL IBR terminal voltage control - superior performance in low system strength, but not widely used or required
 - GFM IBR terminal voltage control – likely not to go through current control

Noticeable GFM differentiation to GFL



GFM inverter vs GFM resource

- Resources designed for GFL operation need **more than inverter control modifications** to provide reliable GFM behavior
- Angle jump or ROCOF trigger different behavior from GFM than GFL
- Load/Generation balance is **more complex in PV solar systems and wind turbines than with BESS**
 - Fast bidirectional active power fluctuations demanded by grid angle fluctuations
 - Drive train has stored energy and constrains(wind)
 - Additional hardware (energy buffer/storage) may be required depending on performance requirements
 - Curtailment
- Current rating and fault contributions

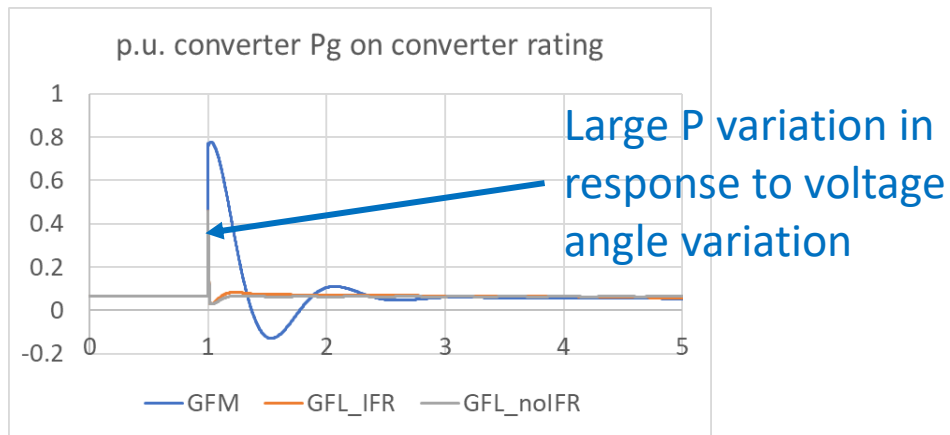

P output in pu from IBR, GFM vs. GFL with and without inertia-like response
Source: Shruti D Rao, et al. "Grid-forming Inverters –Real-life Implementation Experience And Lessons Learned", IET RPG 2021



GFM BESS MW scale projects

- BESS projects are usually not GFM

Key GFM BESS Projects:

- Metlakatla Power & Light 1MW/1.4MWh-1995 [1]
- Vernon CA 5MW/2.5MWh- 1996 [2]
- IID 30MW/22MWh- 2017. Black start of GT auxiliaries and other services
- Entergy Perryville - Black start of GT auxiliaries with 7.5 MW x 7.5 MWh BESS – 2019
- Black start of GT auxiliaries with 13 MW x 13 MWh BESS - 2020

Projects demanded:

- Black start of industrial and complex load (SCR= 0)
- Black start field demonstration
- Modular solutions with distributed BESS



IID (complete, COD: 2Q2017)



Entergy Perryville (complete, COD 4Q2019)

Distributed BESS systems with GFM control approach compatible with interconnected grids



GFM BESS MW scale projects

- Large drives fed from BESS
- Motor and transformer energizations/ Inverter rating optimizations
- Performance Requirement definition are key to design and not simple
 - Current rating vs frequency and voltage sags for critical events
 - Complexity of applications drives need for extensive study efforts
- Few control observations:
 - Hierarchical control with plant-level supervisory controller which sends commands to inverters based on POI measurements (same as most sizable IBR plants)
 - Co-ordinated control between multiple inverters without need for fast communications
 - In islanded mode, plant controller controls voltage and keeps frequency close to nominal



30 x
1.25MVA

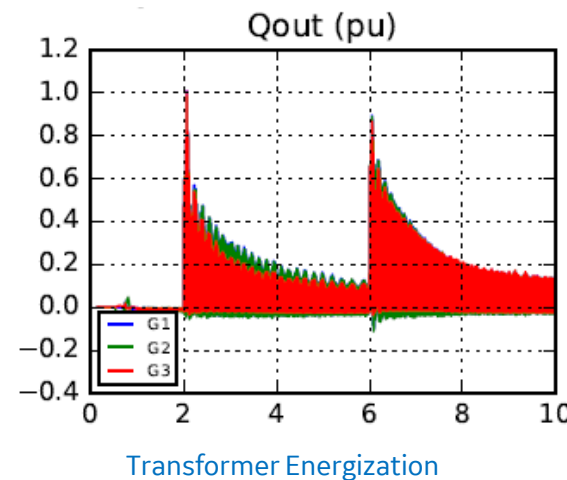
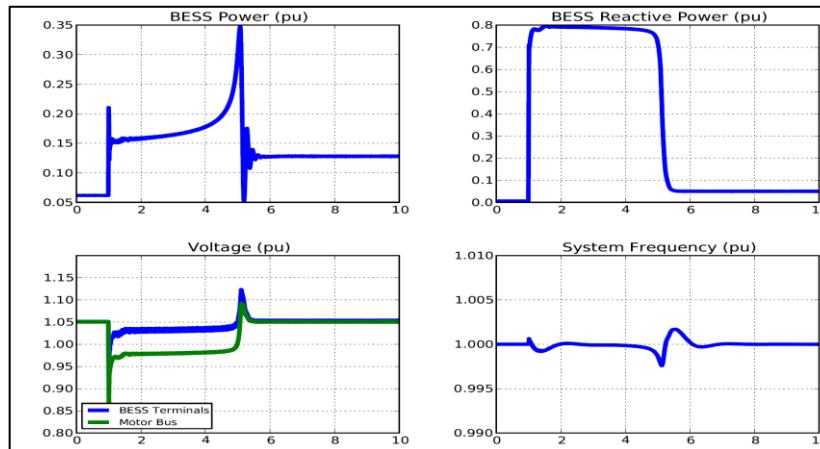
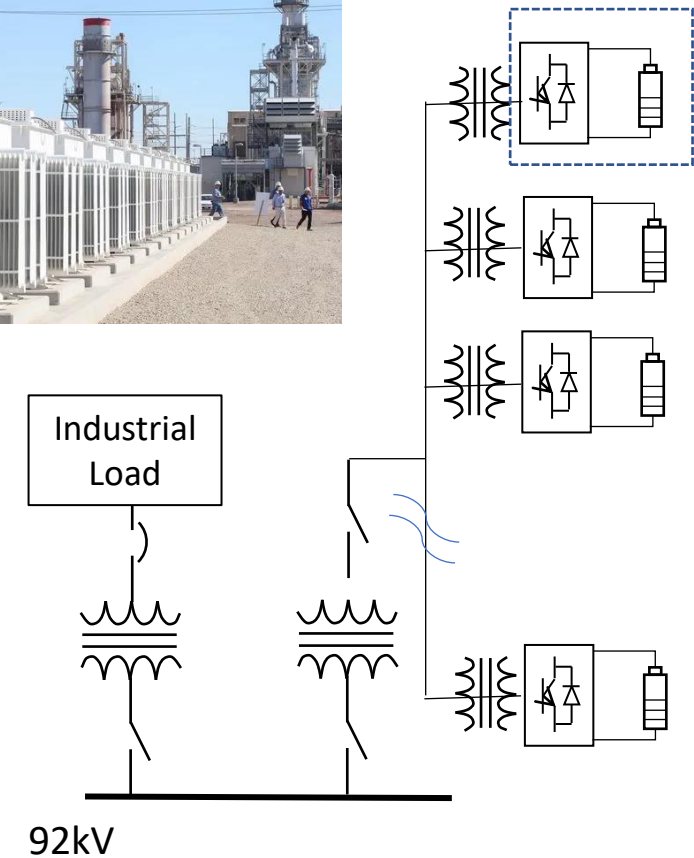

Direct start of large asynchronous machines

Source: Shruti D Rao, et al. "Grid-forming Inverters –Real-life Implementation Experience And Lessons Learned", IET RPG 2021

Performance requirements definitions are complex
How much GFM is GFM enough?



GFM Wind turbine experience

From GFL to GFM...

- Converter, Turbine and plant controls coordination is different
- More Frequent and faster active power fluctuations has impact on drive train
- Several GFM performance aspects benefit from overload capabilities

Type 3 GFM WTG electrical system lab demonstrations well underway

Performance requirement definition

- Performance definitions are different from some of the BESS projects mentioned
- Likely to continue changing as more markets request features
- GFL vs GFM requirement approach may need to be different
- Consideration of equipment limitations

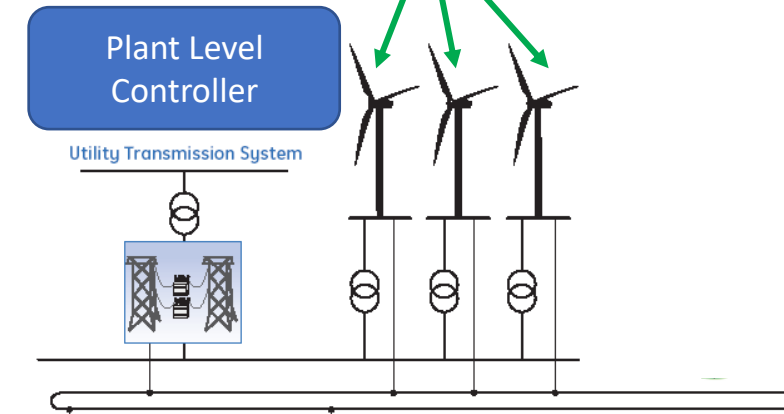

Final Comments

- Grid forming technology can support mitigation of several aspects of low system strength...not all of them.
- GFM performance options are very broad. Performance requirement definition is not simple. Manufacturers require good level of performance definition to design products.
- Several BESS grid forming applications deployed
- PV systems and Wind Turbine design/control based on maximum energy capture. Grid forming operation could lead to significantly reduced energy capture
- GFM capabilities in wind and solar progressing
 - GFM performance requires more than controller code modifications
 - Market size associated to increased performance requirements
- Likely increase in application complexity for stakeholders (Reliability entity, Transmission operator, plant developer, OEMs). Effect in project award/deployment cycles.