

AEMO's Connection Simulator Tool



March 2023



Content to Cover

- Background and the Australian System
- The Connections Simulator Tool Concept
- AEMO Wide-Area PSCAD Models
- Connection Simulator Tool Deep Dive
 - Web Portal Demo
 - AEMO Systems Overview
 - Tool Demo
 - High-Level Systems Recap

Background

About AEMO

AEMO is a member-based, not-for-profit organisation.

We are the independent energy market and system operator and system planner for the National Electricity Market (NEM) and the WA Wholesale Electricity Market (WEM).

We also operate retail and wholesale gas markets across south-eastern Australia and Victoria's gas pipeline grid.



AEMO Services is an independent subsidiary of AEMO, established in 2021 to enable the transparent provision of advisory and energy services to National Electricity Market jurisdictions.



Electricity

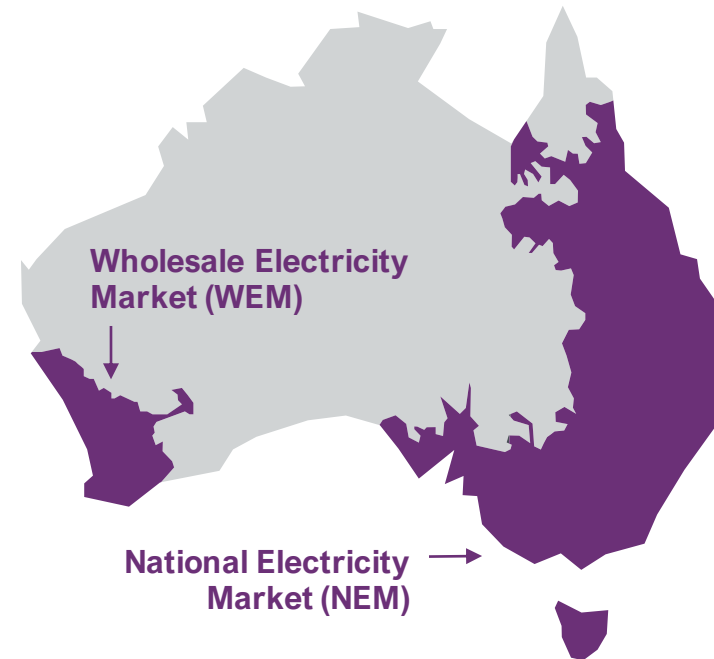

Gas



The Australian Transition

Our Integrated System Plan (ISP) is a 30-year roadmap and calls for development to assist the National Electricity Market (NEM) in catering for

- Almost double the electricity delivered per year by 2050
- Coal-fired generation withdrawing faster than announced, with 60% of capacity withdrawn by 2030
- Nine times the utility-scale variable renewable energy capacity by 2050
- Nearly five times the distributed PV capacity, and substantial growth in distributed storage by 2050

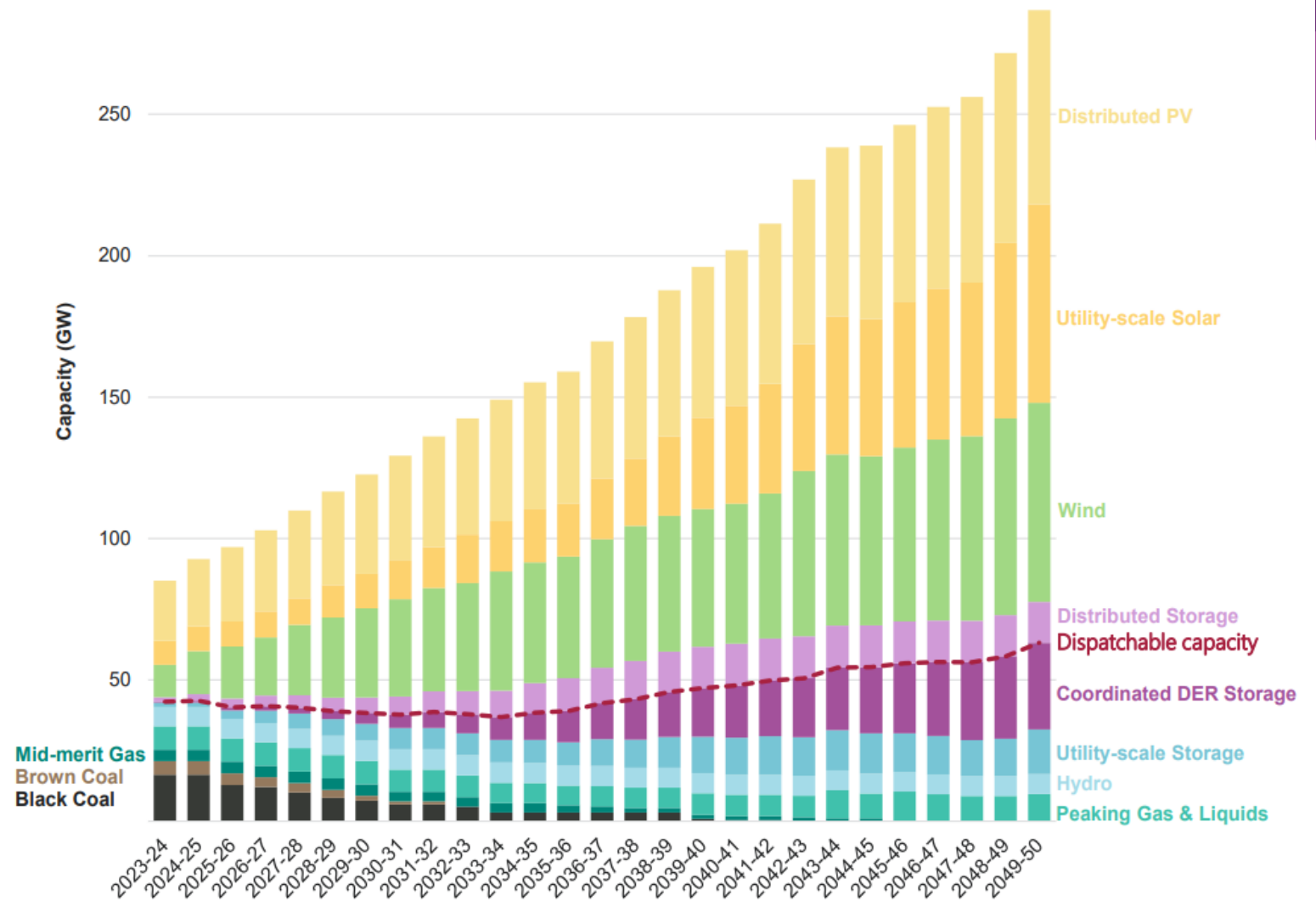

The Connections Landscape



Australia is undergoing the fastest transition of any energy system in the world

- Australia's coal fleet is being retired and the need for generation and storage capacity continues to grow
- 25 projects and 3.56 GW of new generation has been connected to the NEM during FY22 to date
- AEMO National Connections is currently managing over 193 projects, representing 28.3 GW of generation, through the Connections Application, Registration and Commissioning stages of the NEM connection process

The magnitude and pace of the transition means it is critical to get connections right. The speed of transition is creating significant challenges in connecting new projects to the grid and the Connections Simulation Tool can help.

- Our trial users indicated that the Connections Simulation Tool would reduce time to get connected to the grid by 4-8 months
- We have conservatively estimated that the tool will be used for 54 project each year.
- Development of the Connections Simulation Tool is funded by AEMO and the Australian Renewable Energy Agency (ARENA)

All signs point to a quick transition to renewables. But can we connect them?

Giles Parkinson 20 December 2021 13

Share Tweet in 0



Gannawarra solar farm and battery storage facility. Source: Wiresol

Ask any wind and solar project developer about their biggest frustrations in recent years, and it won't take much prompting to find that the connections process – along with a lack of coherent federal policy – has been the biggest bugbear.

There are not many wind and solar projects that have not been hit by delays and cost over-runs that are a direct result of the complex, and sometimes confusing connections process. Some of those delays have run into years, and cost tens of millions of dollars.

Current Generation Pipeline

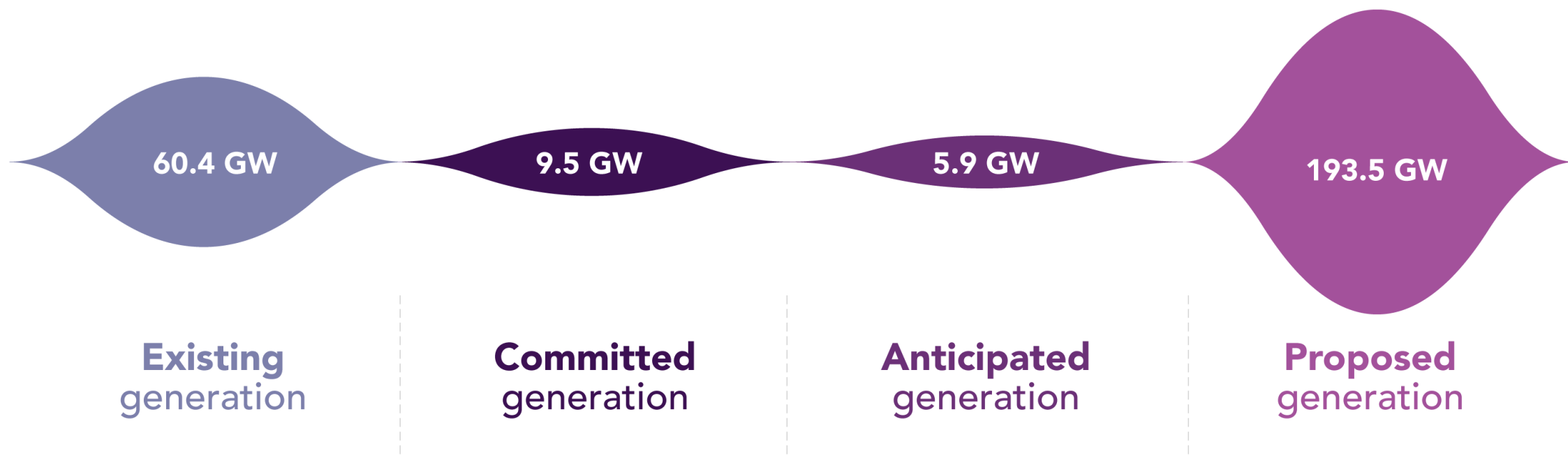

Challenges of EMT Model Assessment



New Connection

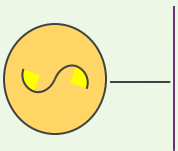

Conducts SMIB EMT Assessments

Finds Issue, Investigates, and Tunes Model

Conducts Approximate EMT Assessments

Finds Potential Fix

Conducts Wide-Area EMT Assessments

Finds Issue, Investigates, and Notifies New Connection

Conducts Wide-Area EMT Assessments



NSPs & AEMO

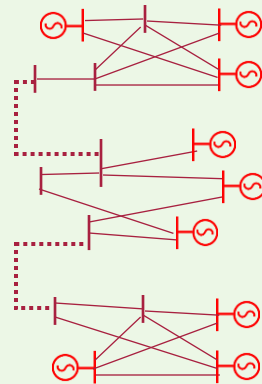

Master Server

The Connection Simulator Tool Concept

Connections Simulator Tool (CST) Concept

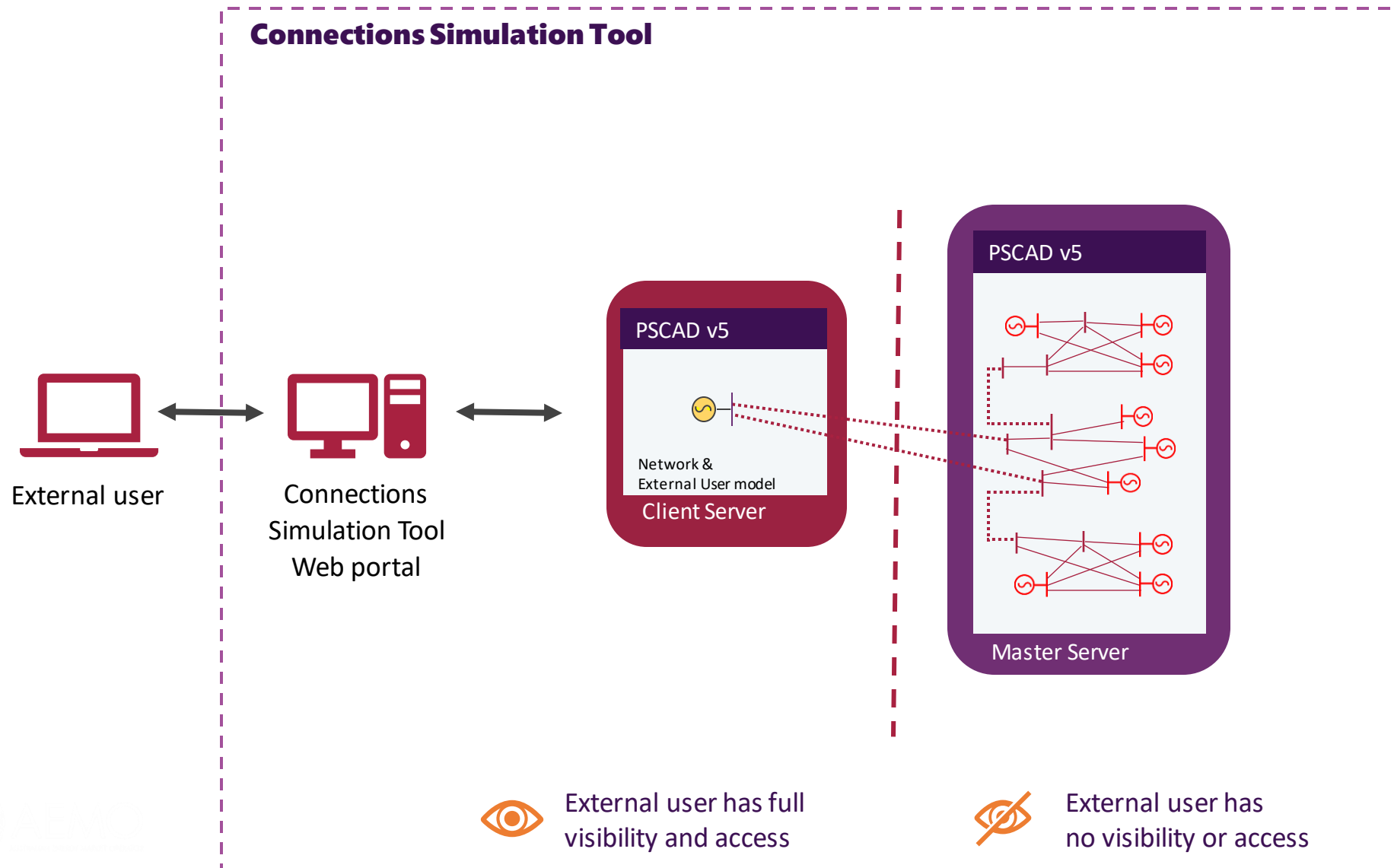

Features:

- Maintaining confidentiality with an electrical connection across two servers (Only Point of Connection visible to user)
- PSCAD Run/Stop scripted automation that's tied to 'Client-side' run
- Client ability to influence the study undertaken
- Measurement transfer between servers
- Automatic deployment and license retrieval of two PSCAD V5 software instances
- AEMO's wide-area PSCAD case used in study
- Ability to automatically generate results request
- And much more!

The Connections Simulation Tool

The Connections Simulation Tool seeks to streamline the connections approval process by enabling user-run EMT studies that utilise AEMO's four-state model.

Proponents use a web portal to submit a plant model which is then configured in a dedicated cloud-based PSCAD environment



Faster path to finalising plant design

- Better understand plant interactions with the NEM
- Improved model quality
- Early identification and mitigation of problems



Resulting in
Time Savings

- Fewer Connections Process iterations equates to less time



Resulting in
Cost Savings

- Less time to get approvals means that a plant can be operational sooner
- Lower overall risk

*MVP Trial User feedback

Key facts



Optional Service
Independent of, but will support, the connections process



Fee-for-service
The service will be charged on a cost recovery basis



Confidentiality
Plant model confidentiality is protected



Industry Collaboration
AEMO partnered with industry to develop the solution



Delivered in 2022
The first release of the service was launched in November 2022

Users of the Tool

Initially the tool is available for studies related to connections applications in the mainland NEM. There are a number of other use cases that have been identified for future access to the tool.



DEVELOPERS

Supported

Use the tool (or provide access permission) for studies to be conducted on their prospective plants

Future development



OEMs

Supported

Study prospective plant behaviour on behalf of the developer

Develop and pre-screen models on a representative system



CONSULTANTS

Supported

Study prospective plant behaviour on behalf of the developer



NSPs

Study a prospective plant, components of the network or system behaviour



RESEARCH/EDU

Test generic plant model, or system behaviour, conceptual design of a generator

Engagement & Rollout

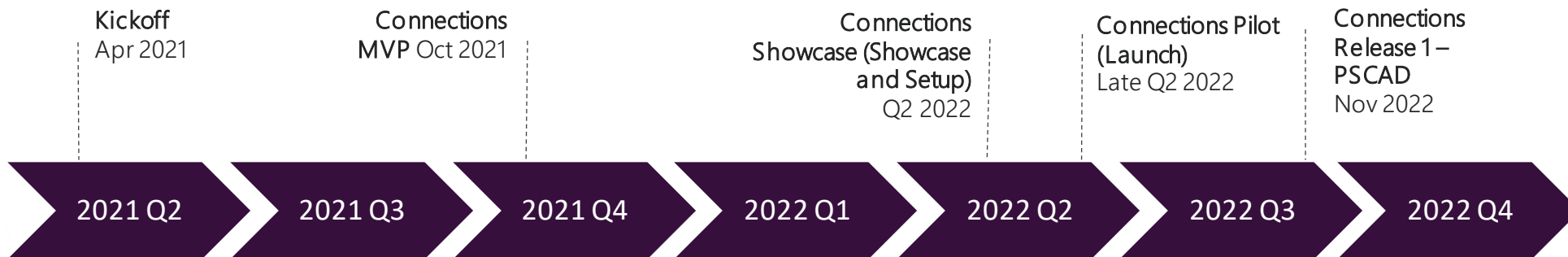

Interest in the Tool

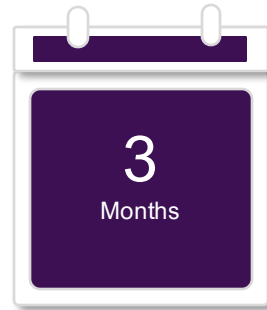

At Months since launch

The Connections Simulation Tool was launched on 16th Nov.

Information relevant as at 16 Mar 2023

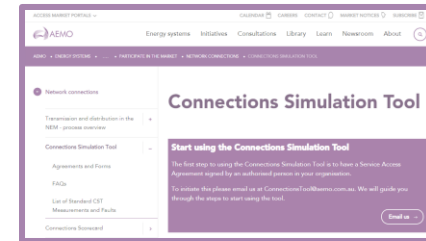

See AEMO's website about how to apply to use the tool

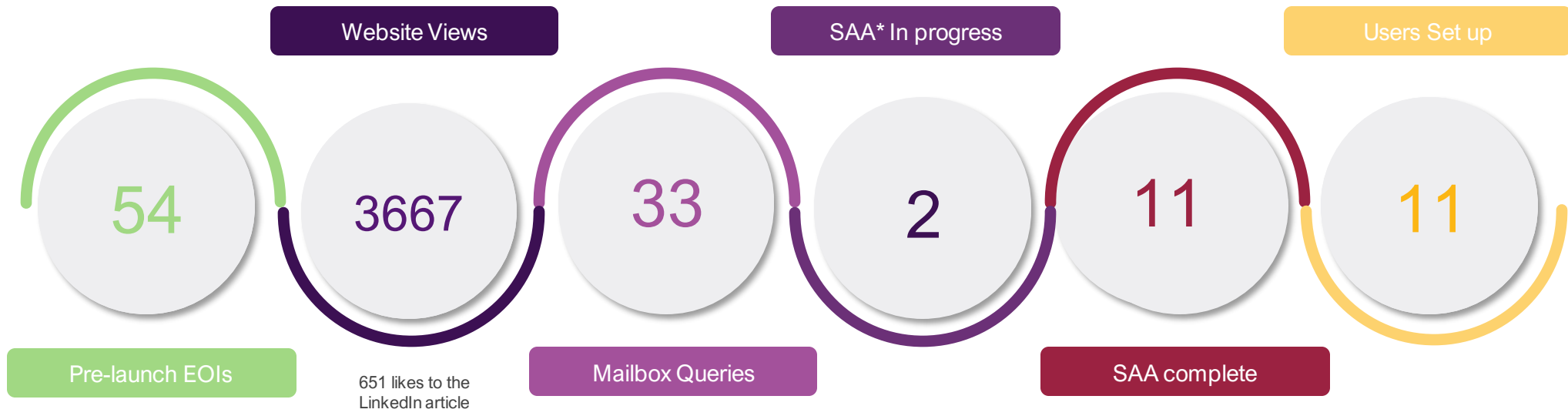

Challenges

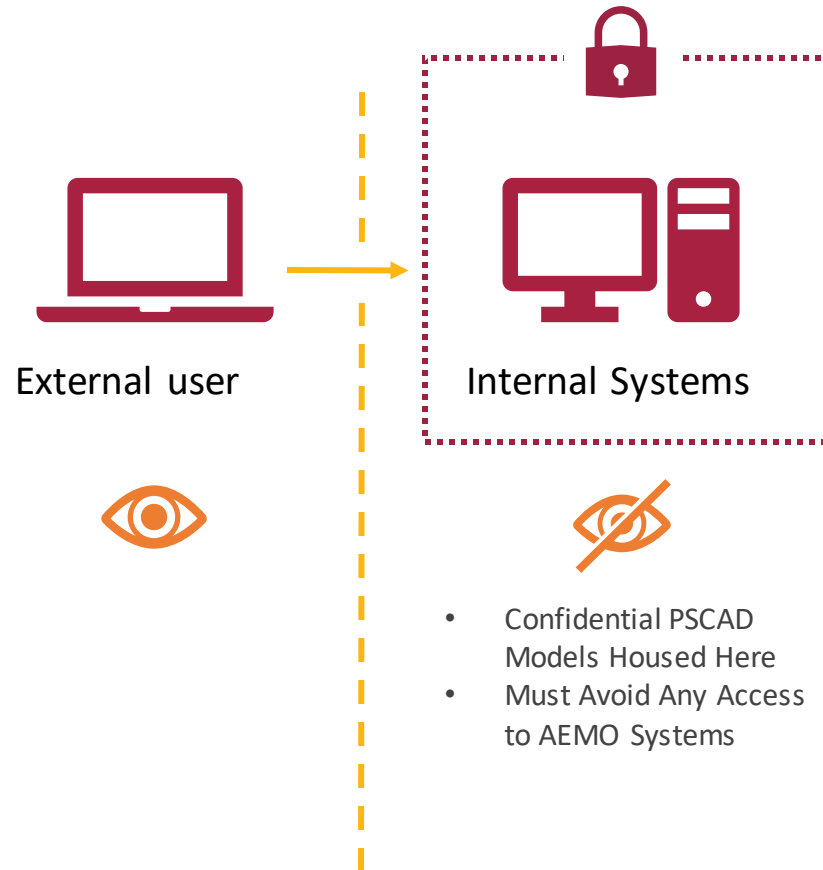

SYSTEM SECURITY



Building streamlined automated systems was necessary to make the project workload on AEMO engineers feasible

AUTOMATED SYSTEMS

AEMO's Wide- Area PSCAD Model

NEM Mainland EMT (PSCAD) Model



~3,500 bus network

Voltage levels ranging from 11-500 kV

184 asynchronous generator & SVC models

220 individual PSCAD project spaces

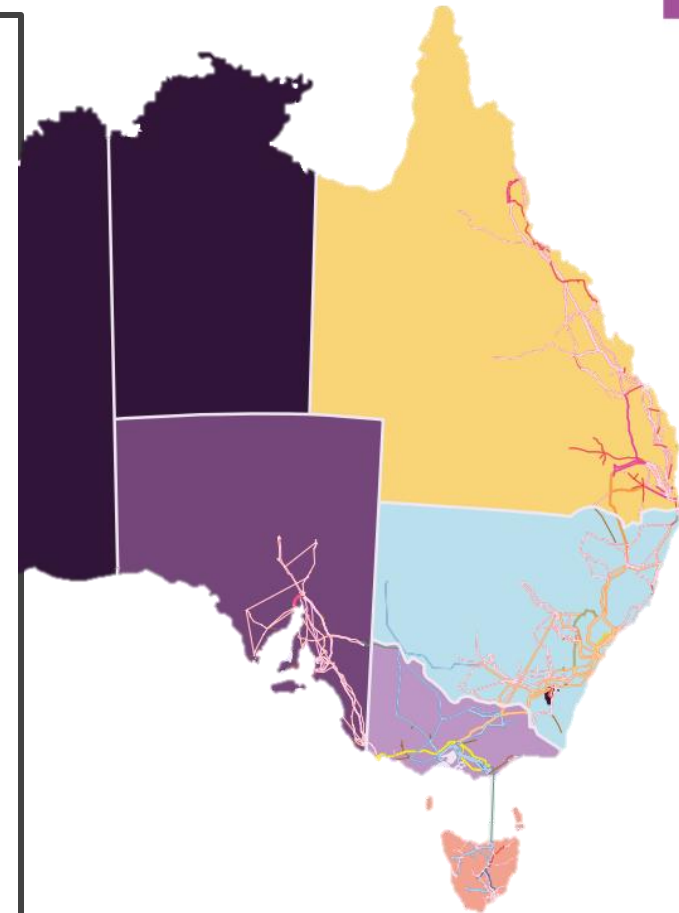
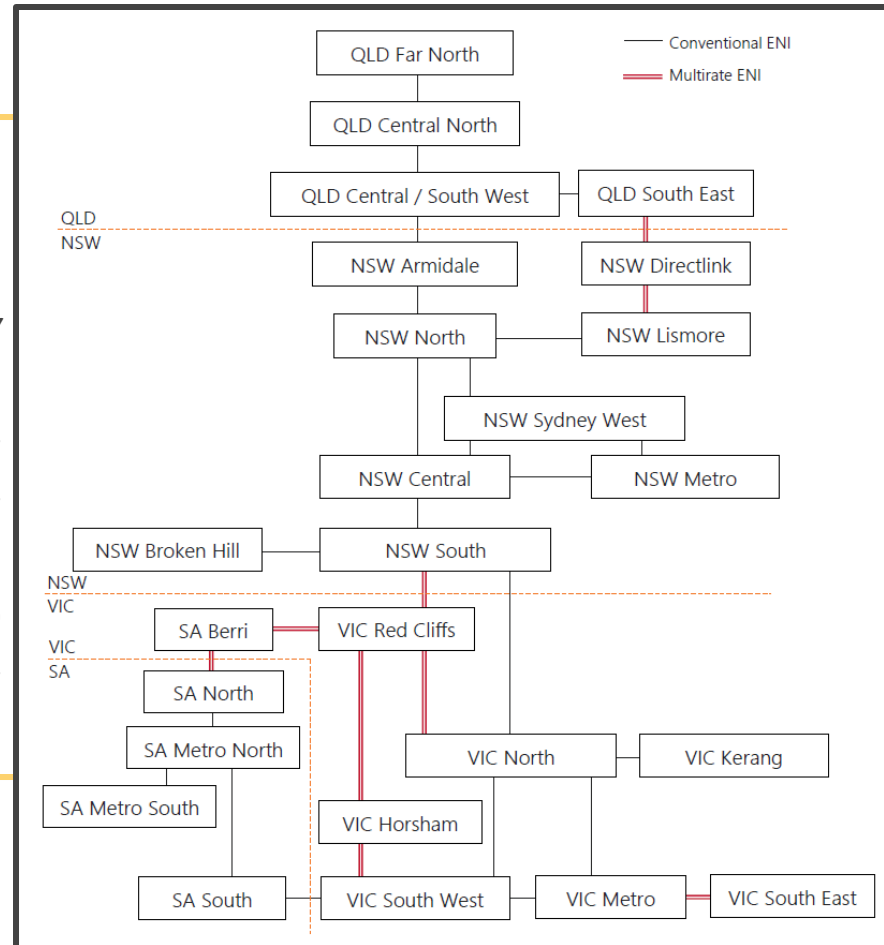

PSCAD Model Features

'PSCAD Tools' Python Application

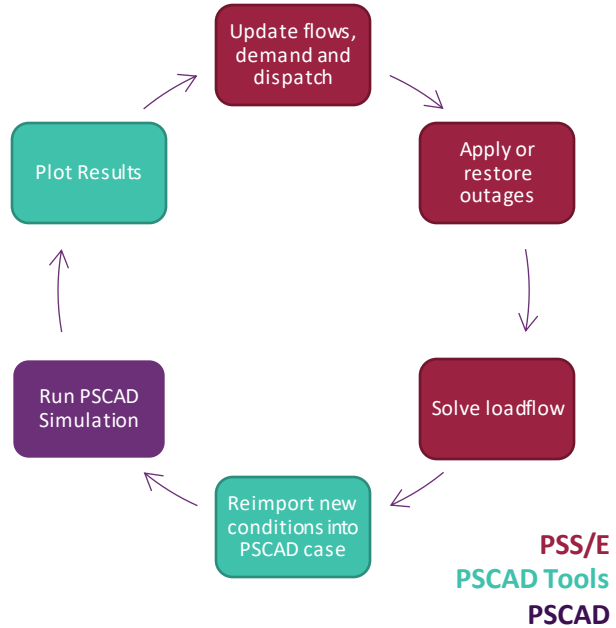

Disturbance Controller

Disturbance Controller			
Time	Duration	Type	Location
20	0.5	Phase AB to Ground	[356090] Derang - South Murray

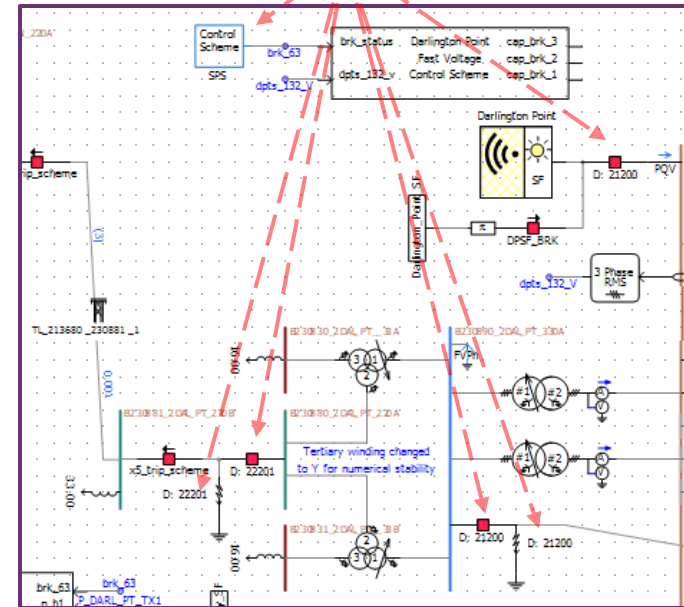

Resources are available on the AEMO PSCAD wide-area models

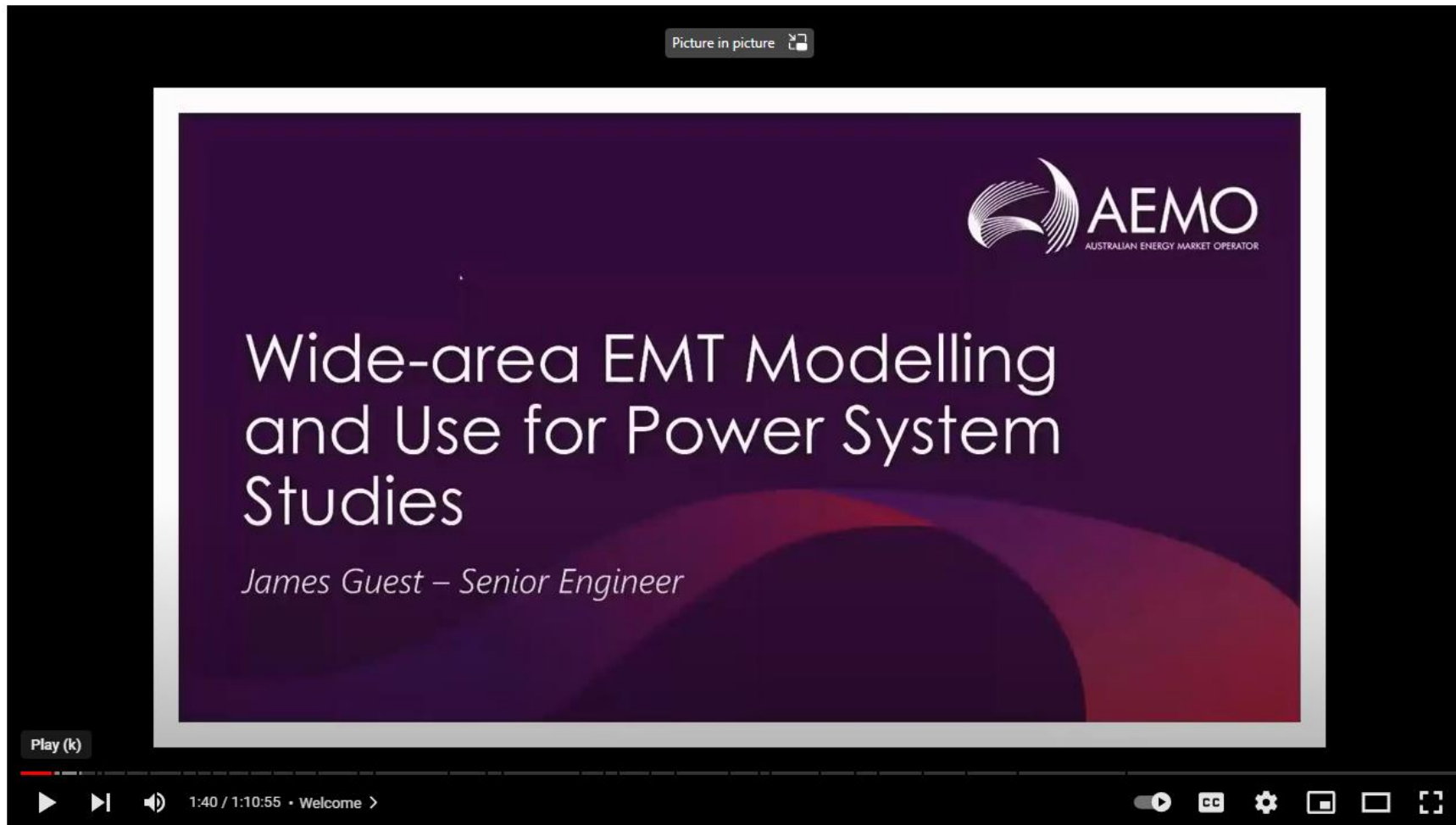

Picture in picture

 AEMO
AUSTRALIAN ENERGY MARKET OPERATOR

Wide-area EMT Modelling and Use for Power System Studies

James Guest – Senior Engineer

Play (k)

1:40 / 1:10:55 • Welcome >

Cutting edge technologies towards a net-zero world - Joint UK & AU NGN Event

Connections Simulator Tool Deep-Dive

User Process

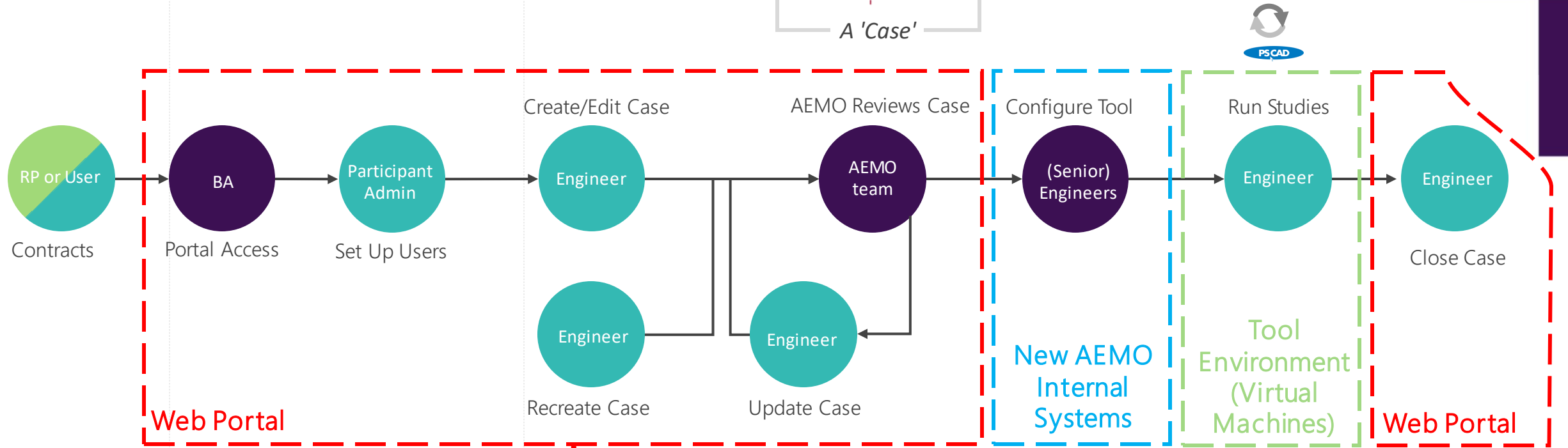
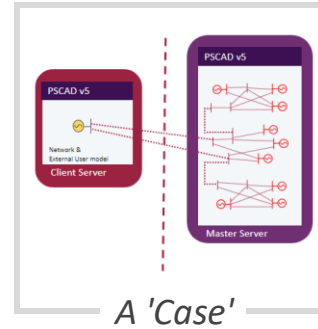

Next Slide

Billing occurs on a monthly basis and invoiced to the company that undertakes the studies in the tool

System	Email	System Access Management (SAM)	Connections Simulation Tool – Web Portal
--------	-------	--------------------------------	--

Key: ● AEMO ● Developer/registered participant ● Developer or delegated Consultant/OEM (Conducts studies and is billable entity)

Web Portal Demo

User Process

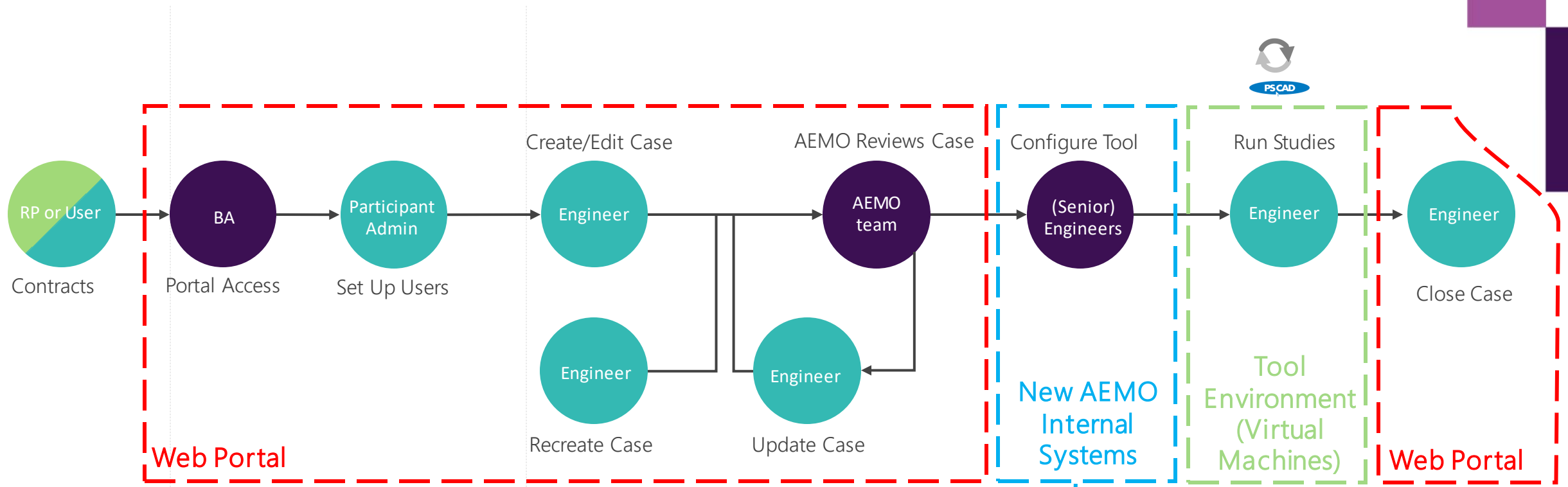

Billing occurs on a monthly basis and invoiced to the company that undertakes the studies in the tool

System	Email	System Access Management (SAM)	Connections Simulation Tool – Web Portal
--------	-------	--------------------------------	--

Key: ● AEMO ● Developer/registered participant ● Developer or delegated Consultant/OEM (Conducts studies and is billable entity)

Network Case Setup

Work completed by AEMO

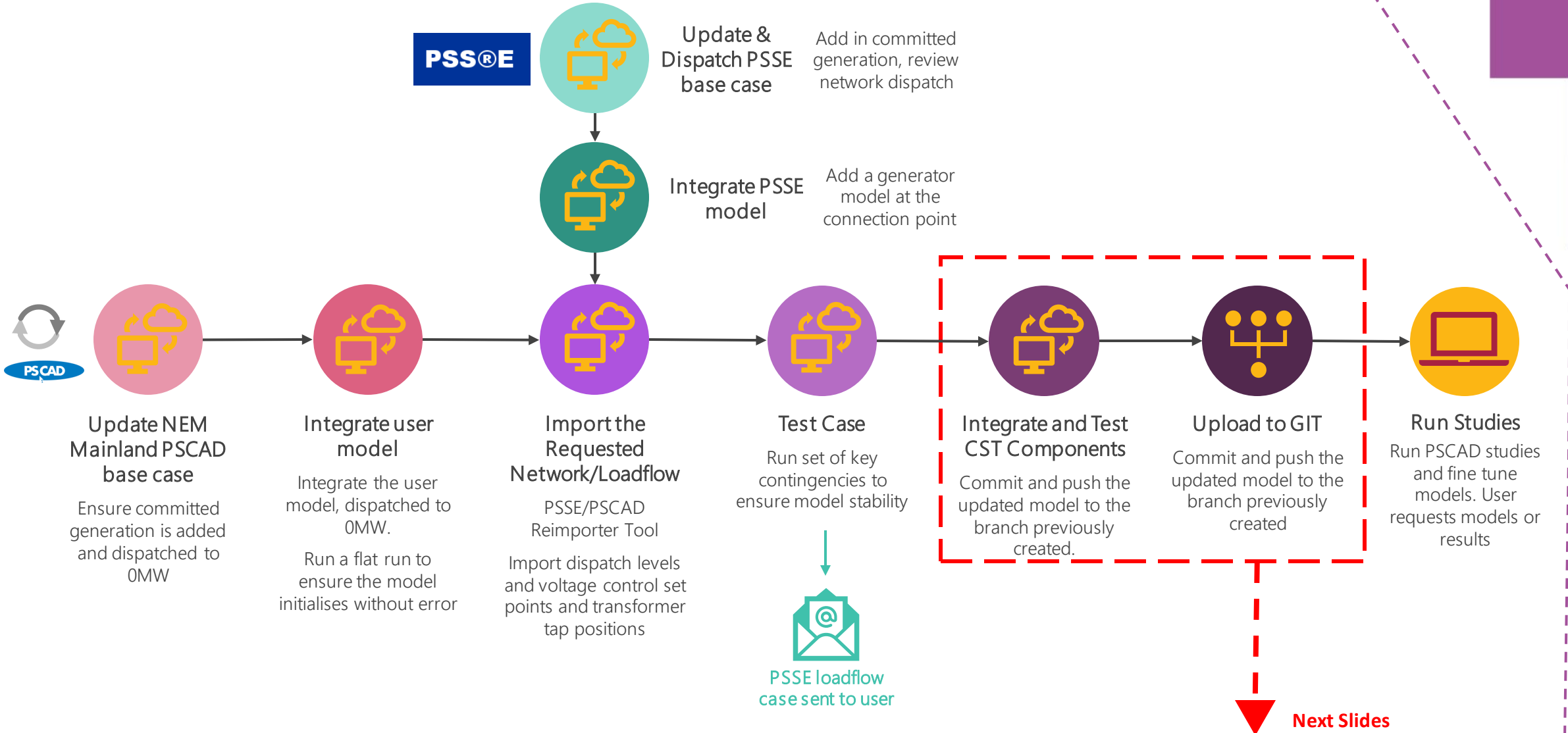

AEMOs CST Management Tools

Work completed by AEMO

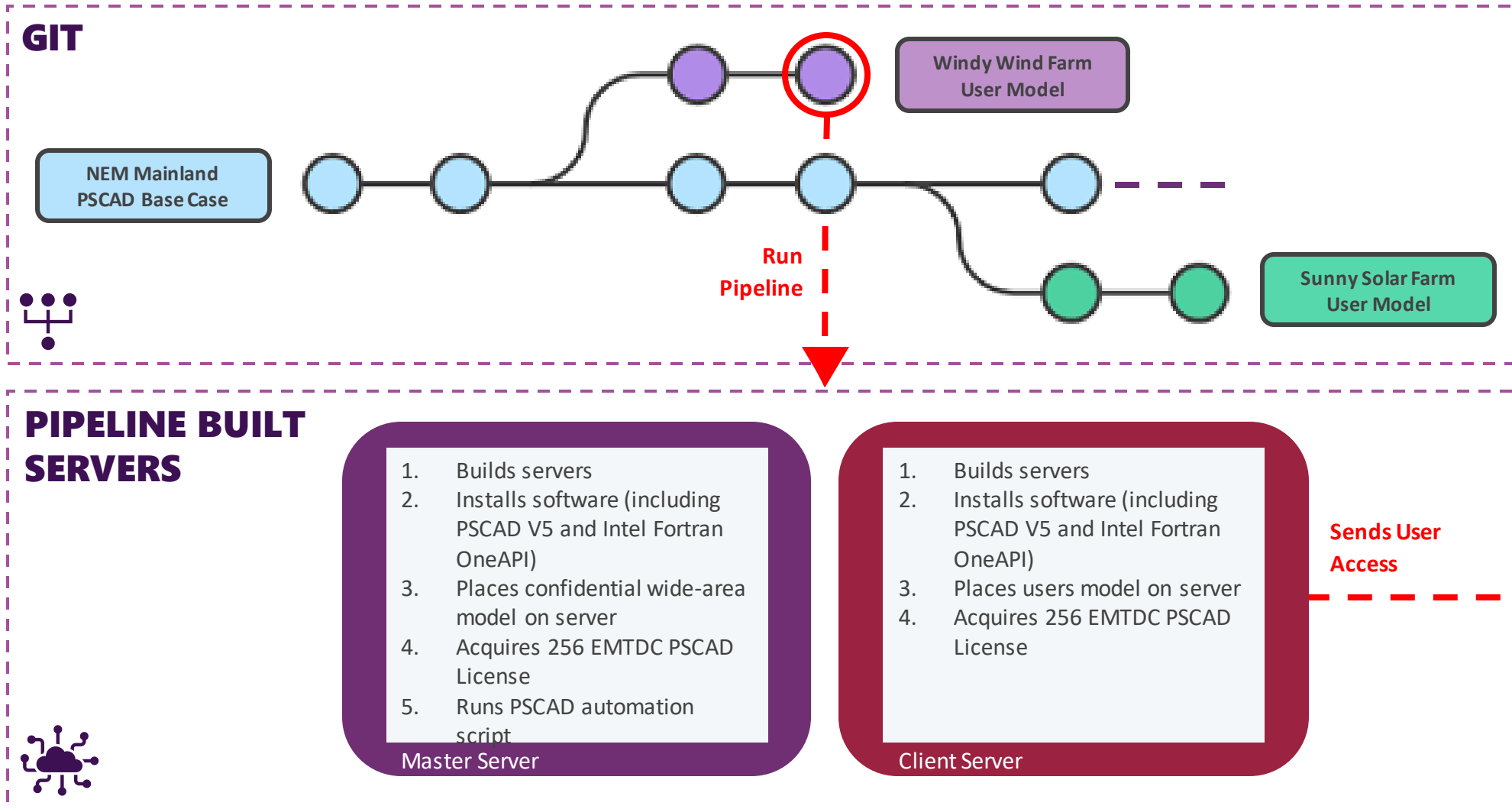

User Process

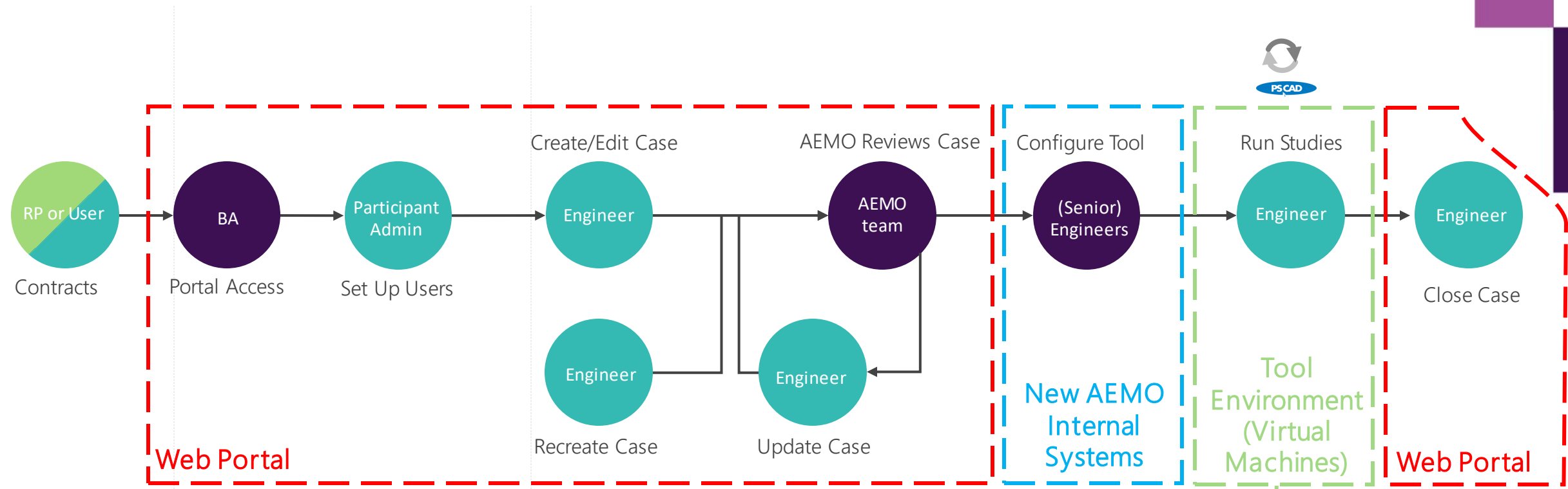

Billing occurs on a monthly basis and invoiced to the company that undertakes the studies in the tool

System	Email	System Access Management (SAM)	Connections Simulation Tool – Web Portal
--------	-------	--------------------------------	--

Key: ● AEMO ● Developer/registered participant ● Developer or delegated Consultant/OEM (Conducts studies and is billable entity)



Next Slides

Tool Demo

Systems Overview

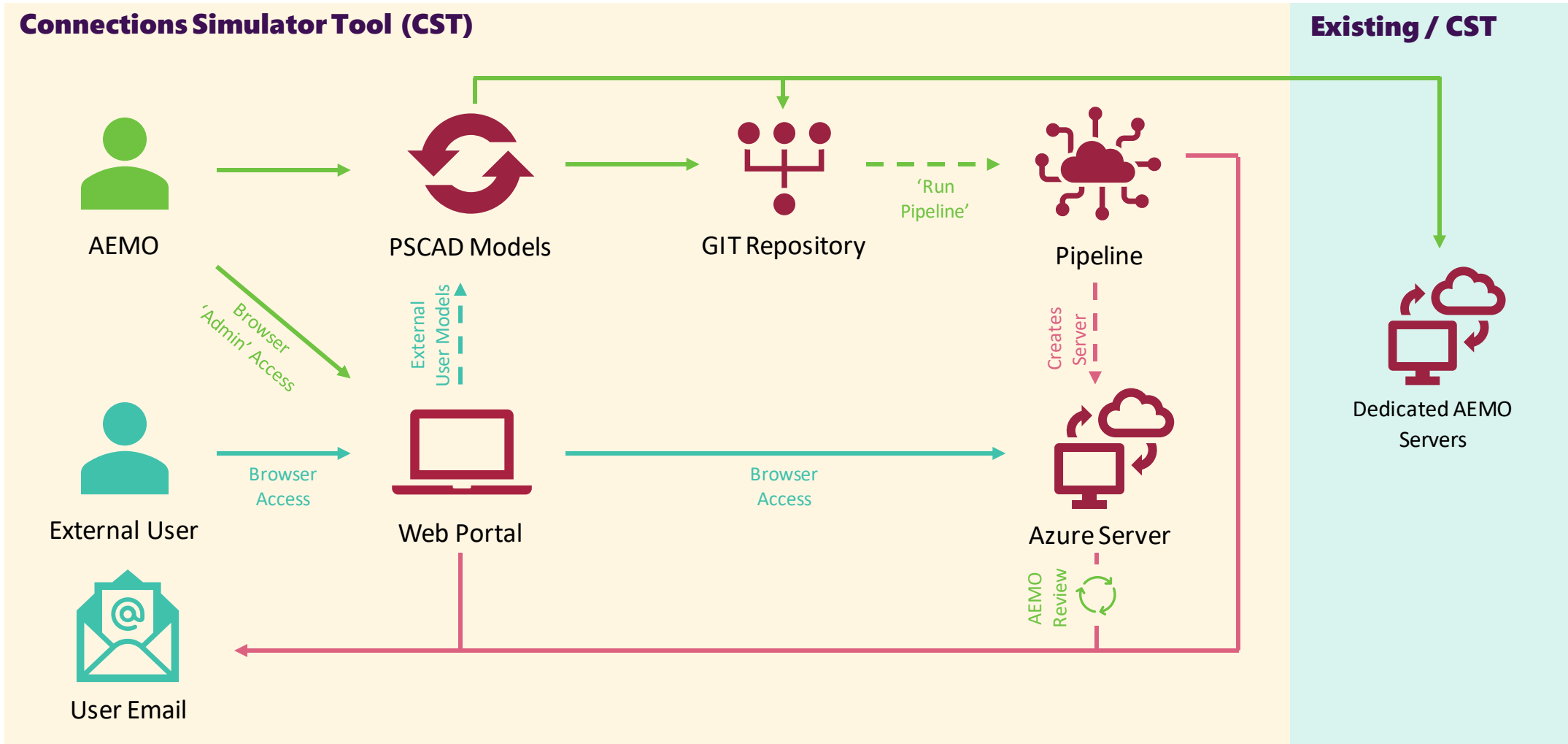



AEMO

AUSTRALIAN ENERGY MARKET OPERATOR

Questions?



For more information

Visit: [AEMO Connections Simulation Tool website](#)

or

Email: ConnectionsTool@aemo.com.au

Simulation within the CST

Client Server

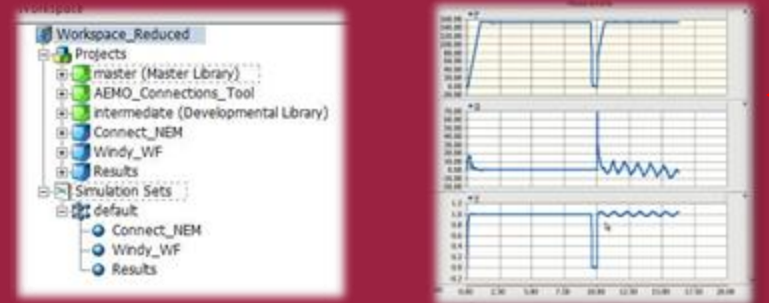

Workspace | **NEM Results**

Disturbance Controller			
Time	Duration	Type	Location
15 (s)	0.5 (s)	Phase ABC to Ground	[20021] Eraring Unit 1 Transformer 330kV Side Terminal
20 (s)	0.7 (s)	Phase AB to Ground	[20103] Baywater Unit 3 Transformer 500kV Side Terminal

Disturbance Selection

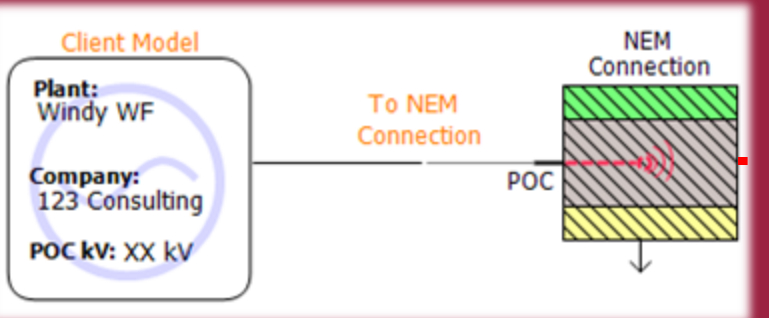

Client Model

- Plant: Windy WF
- Company: 123 Consulting
- POC kV: XX kV

NEM Connection

To NEM Connection

POC

Electrical NEM Connection

Master Server

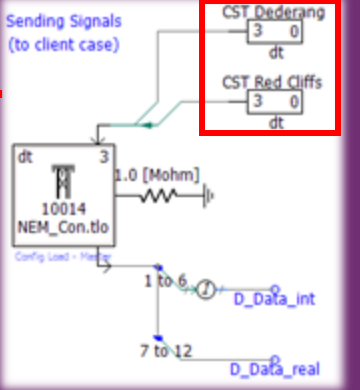

Sending Signals (to client case)

CST Ordering
CST Red Cliffs

10014 NEM_Con.tio

1.0 [Mohm]

1 to 6: D_Data_int

7 to 12: D_Data_real

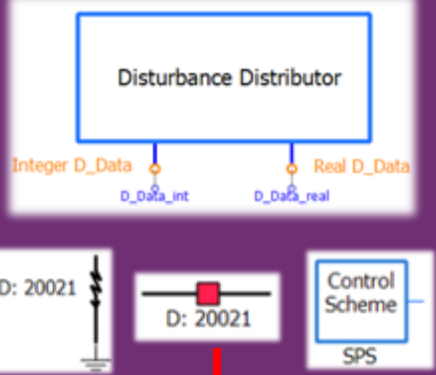

Disturbance Distributor

Integer D_Data: D_Data_int

Real D_Data: D_Data_real

D: 20021

D: 20021

Control Scheme SPS

NEM Measurement Transfer

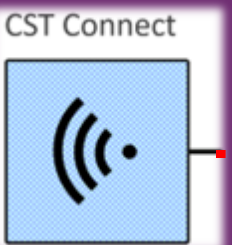

CST Connect

Electrical Client Connection

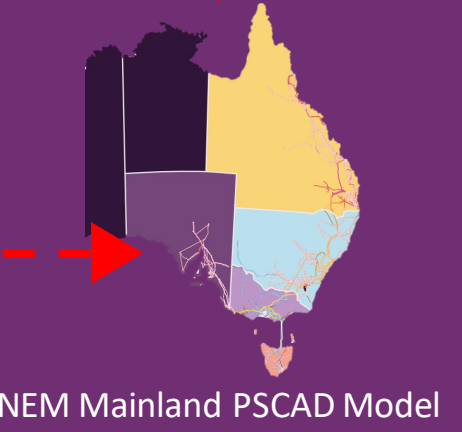

NEM Mainland PSCAD Model

Functionality Overview



Pipeline

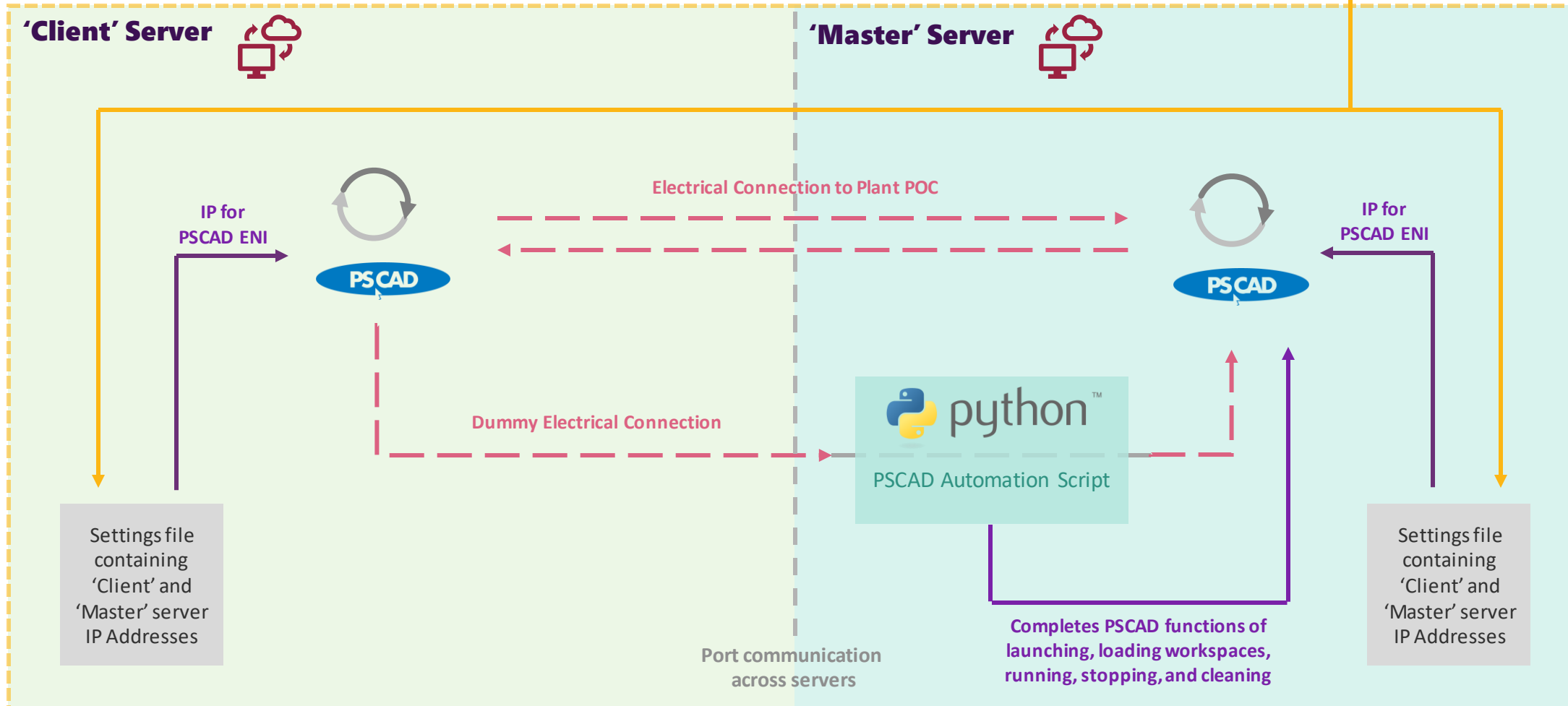

The Future of the Connections Simulator Tool

Where to from here?

The Connections Simulation Tool will continue to evolve. Planning on further development of the tool is well progressed.

Trial Versions



Tested the concept with a sample of industry users

Release 1 – 16 Nov 2022



The first release will enable users to test their models at the Point of Connection (PoC).

The Future of the Connections Simulation Tool



Earmarked Connections Simulation Tool development includes

- **Greater visibility of the neighbouring network:** Provide visibility to more of the network, beyond the PoC. Enabling more flexibility for users
- **Enhance current features and services :** Building on Release 1 backlog and continuing to improve the service

In addition the solution may be utilised to support the exchange of sensitive information such as plant models in the broader connections process

The aim is to continue the shift where industry is empowered to better fine tune their models. This will

- Free up AEMO teams to focus on other work
- Speed up connections process for industry users
- Accelerate the transitions of renewables into the grid

Network Visibility Options

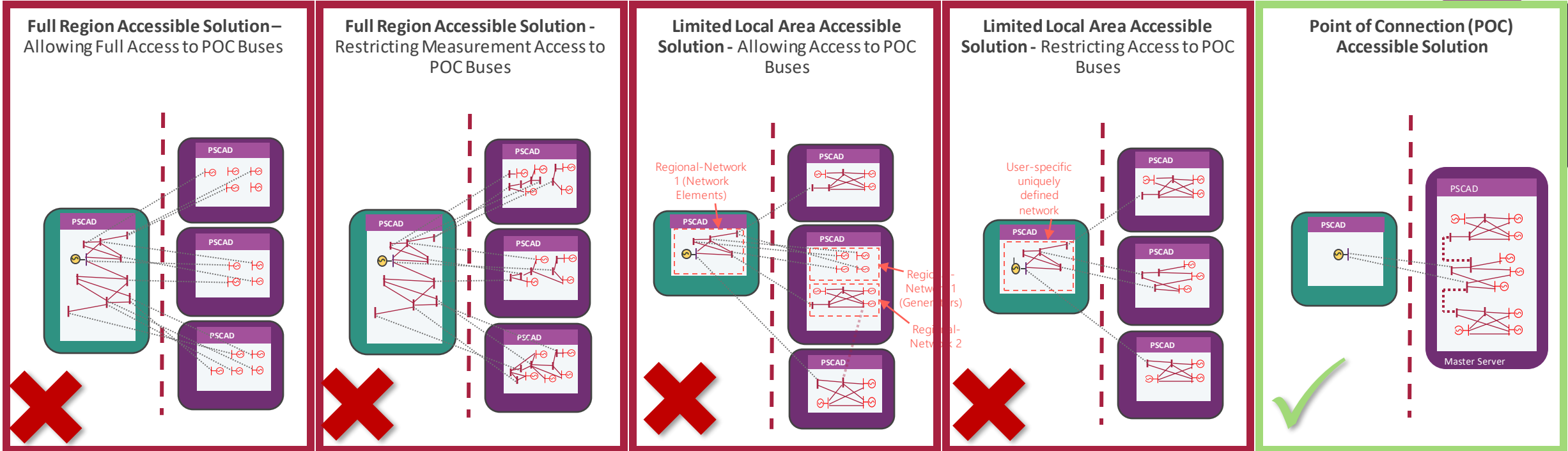

Individual plant models moved into new workspace and ENI connections updated to be cross-server

Plant local networks broken into many sub-networks to protect POC buses, with ENI connections created between sub-networks and the remaining network

Single regional-network broken into its own model, with its individual plant models moved into new workspace and ENI connections updated to be cross-server

A limited, user-specific sub-network defined which protects all other plants POC's, with ENI connections added between uniquely defined sub-network and the wider network models

ENI connection created between user's POC and wider network models

Key: ■ Full Network & External User model
External user has full visibility and access

■ Confidential Generator Models
External user has no visibility or access

Improved Run Automation



Pipeline

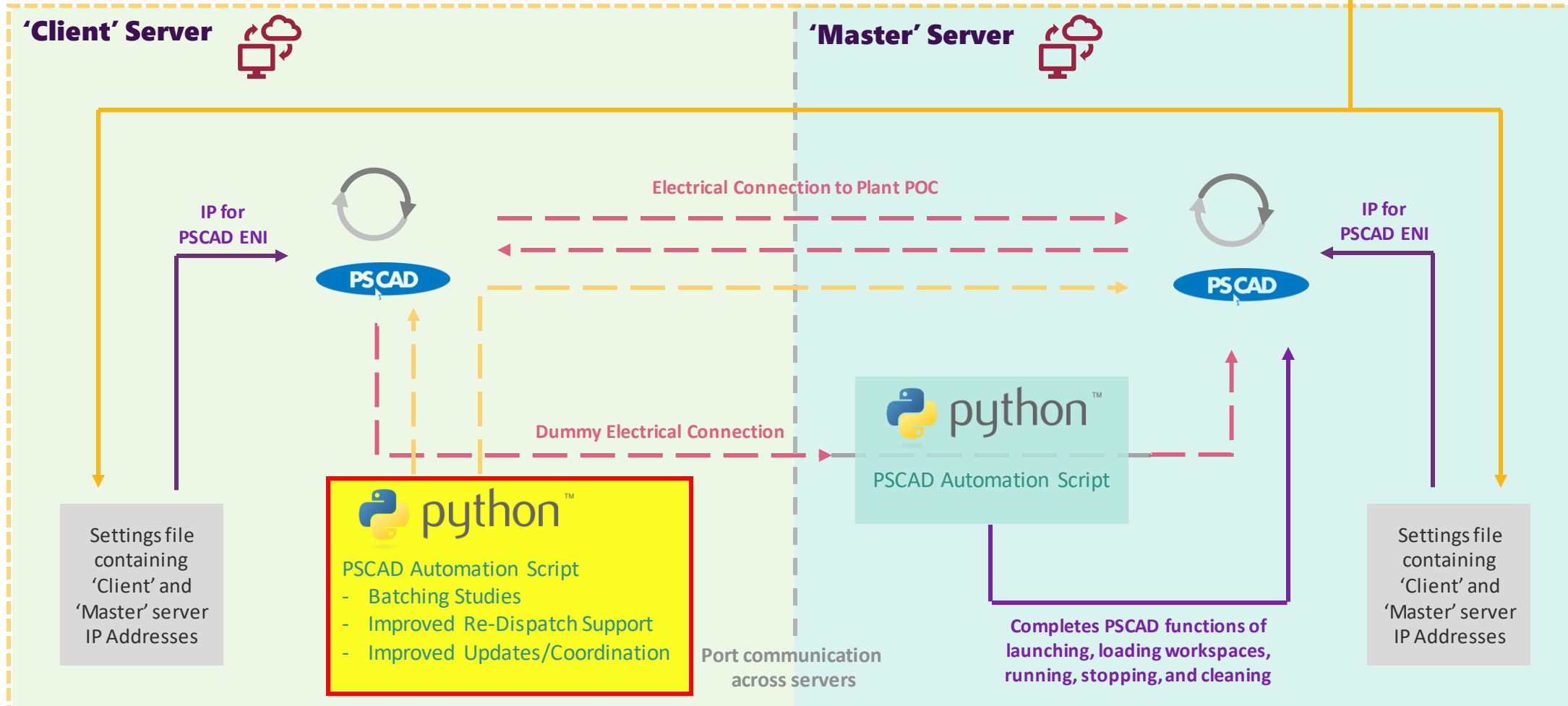

PSCAD Model Structure

