



Renewable Power Plants Interaction with Power Grid and Grid Code Practices in China

Dr. CHI Yongning

**Chief Engineer of renewable energy department, CEPRI
CTO, Institute of Technology and International Standard, Beijing
Secretary, IEC TC 8/SC 8A – Grid Integration of RE Generation**



2022 SPRING TECHNICAL WORKSHOP

March 21-24, 2022
Loews Ventana Canyon Resort
Tucson, AZ

1

Impact of high penetration of RE generation

2

RE power plants interaction with power grid

3

Grid requirements upgrading and standardization

1. Impact of high penetration of RE generation

□ Renewable Energy

- ✓ By end of 2021, the total installed capacity of renewable energy in China reached 635GW (328.5 GW wind and 306.5 GW PV), accounting for 26.7% of China total installed capacity.
- ✓ At least 50 TW (50亿) wind and solar PV by 2060.

□ UHV AC and DC Projects

- ✓ 14 AC and 12 DC UHV projects had been built up, 2 AC and 3 DC UHV projects are under construction, with total transmission capacity over 450 GVA (GW)

- Highly-Penetrated RE and Long-Distance HVDC Transmission significantly change the power system dynamic performance, and the interaction between renewable energy and the bulk power grid are dramatically increased, which causes many new issues and influence the grid security and stability.

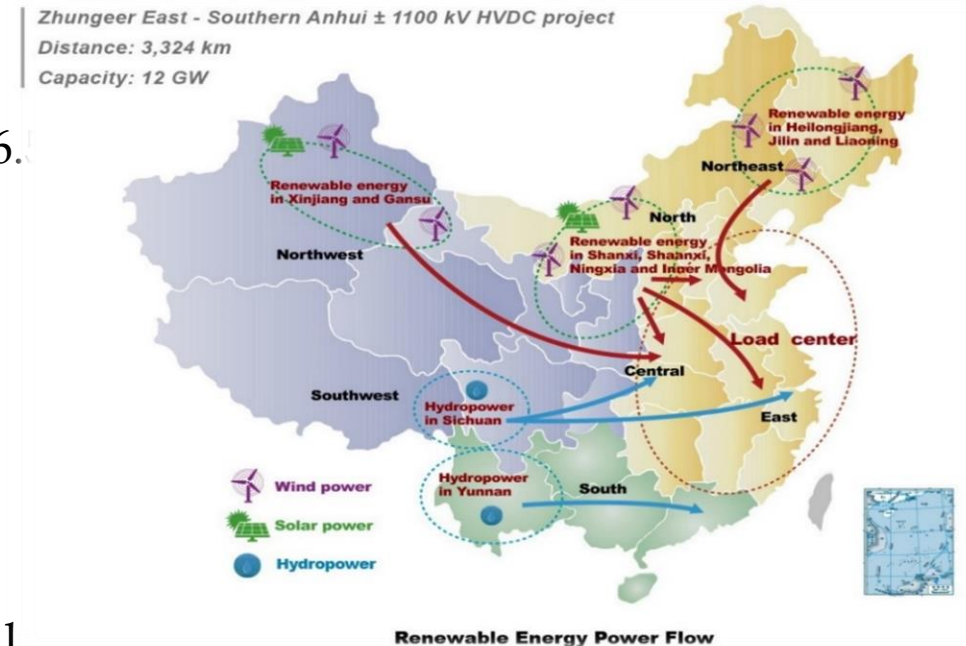

1. Impact of high penetration of RE generation

□ Gansu Province, 2.24, 2011, wind power outage.

- ✓ Large amount of wind turbines tripping occurred in JiuQuan (酒泉) wind power base; the main reason is because most of wind turbines are not capable of riding through the system faults.

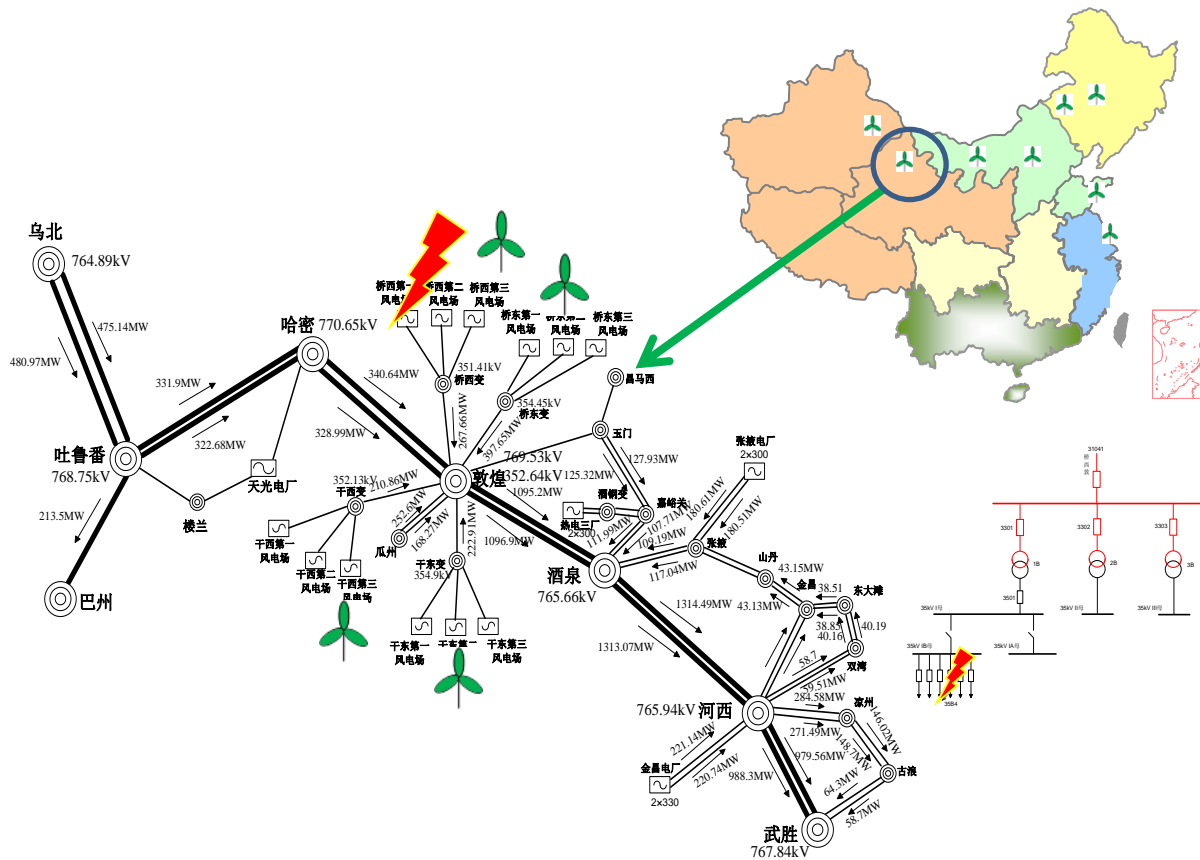

The type of wind turbines

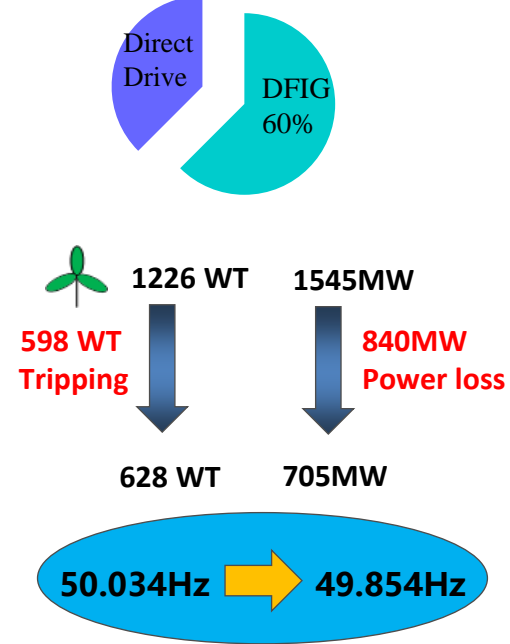

- ✓ Wind turbines are not with LVRT capability.
- ✓ Large wind turbines tripping cause big load flow change.
- ✓ Q power compensation devices (Shunt capacitors) at wind farms are not flexible controlled.

1. Impact of high penetration of RE generation

□ Xinjiang, 07.01, 2015, Sub-Synchronous Control Interaction

- ✓ On July 1, 2015, wind farms (type 4 turbines) in Xinjiang Hami interacted with the weak AC grid and, the full converter controls actively participate in defining the characteristics of the interaction. The post-fault analysis on the data recorded by PMUs showed that the direction of subsynchronous power is from renewable power (A/B/C) to the thermal power plant M.
- ✓ The frequency matching with the natural frequency of the shaft (30.7Hz) of the neighboring synchronous generators modes cause torsional oscillation, torsional vibration protection triggered leading to a tripping of 3 Units each with 660 MW.

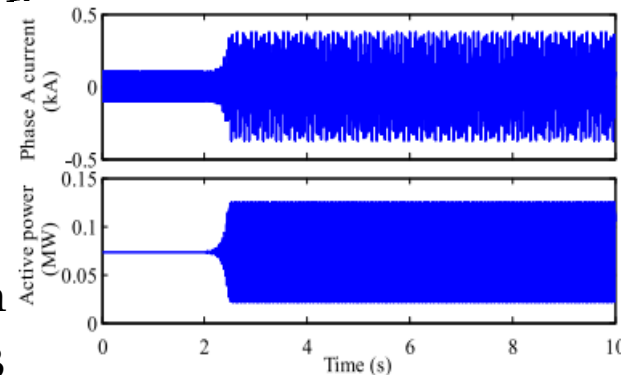
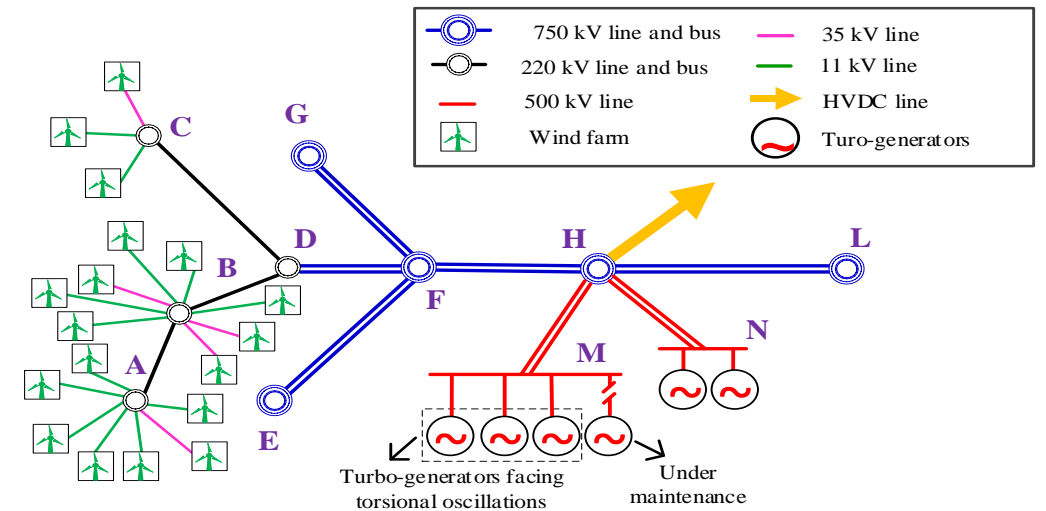

Current (upper plot) and active power (lower plot)

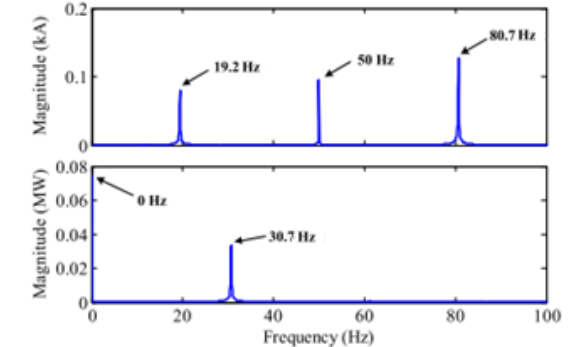

Frequency spectrum of the current (upper) and active power (lower)

1

Impact of high penetration of RE generation

2

RE power plants interaction with power grid

3

Grid requirements upgrading and standardization

2. RE power plants interaction with power grids

- With the proportion of RE increasing, conventional power sources are largely replaced by RE, in some provinces more than 30-40% of total installed capacity are RE, system's inertia and frequency regulation capability continue to decrease.

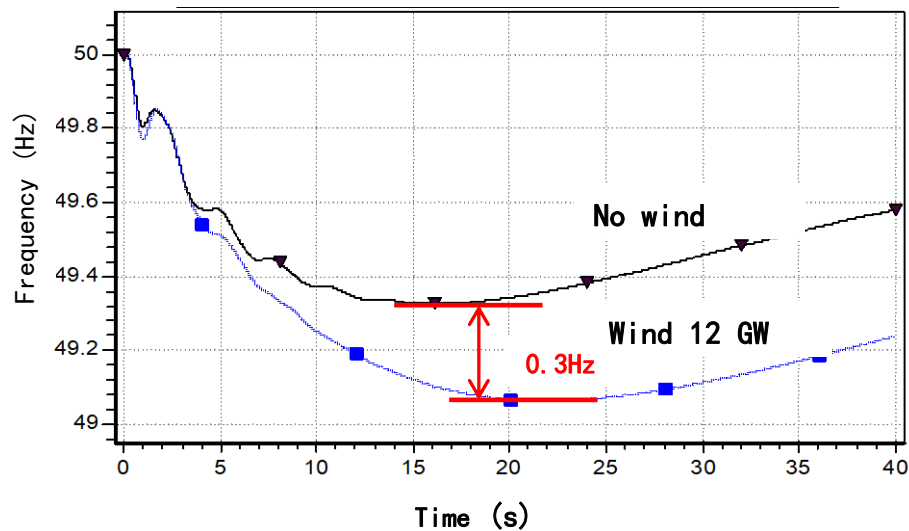

The Northwest Power Grid (2015) loses 3.5 GW power at a load level of 68 GW. In the scenario of 12 GW wind power, the system frequency drop will be 0.3 Hz lower than no wind scenario.

- Jin-Su HVDC (from Sichuan Xichang to Jiangsu Suzhou, $\pm 800\text{kV}$, rated capacity 7600MW) Bipolar Block Fault in 9.19, 2015, leading to a power loss of 4900MW to the East China System, the system frequency dropped to 49.56 Hz.

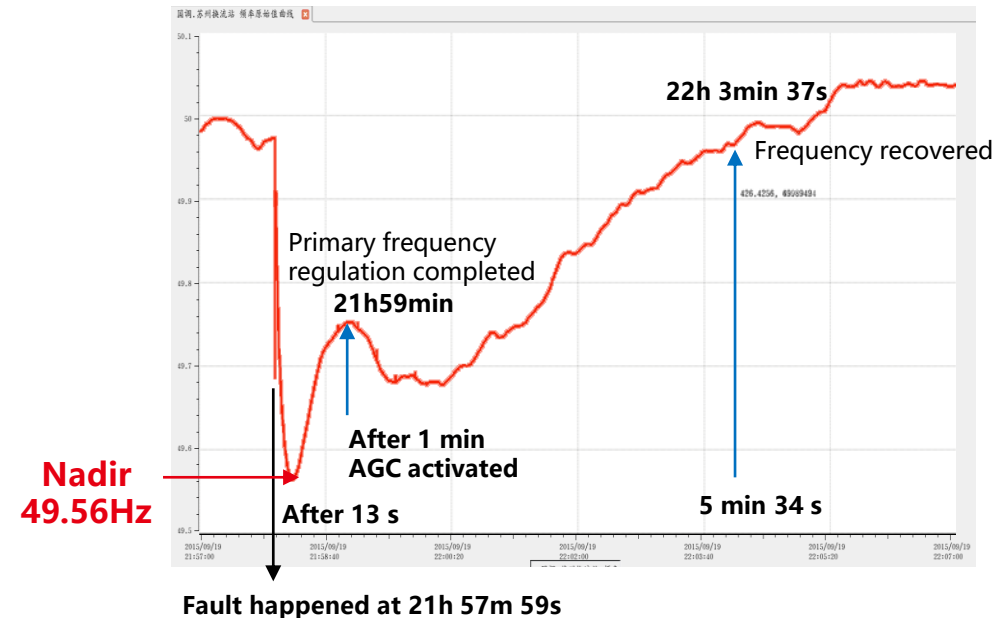

East China system frequency drop during the bipolar block failure of Jin-Su HVDC Project in 2015.

2. RE power plants interaction with power grids

□ Main reasons of LCC-HVDC system commutation failure are the low grid strength or system short circuit at the receiving terminal. Commutation failure causes the power, voltage and frequency fluctuations of both sides.

□ HVDC system's commutation failure causes an over-voltage at the sending terminal of AC system with a 60-100ms duration, 2 times successive commutation failure will last for 400-500ms. If the HVRT function not equipped, the wind turbines shall have a risk of disconnection by over-voltage.

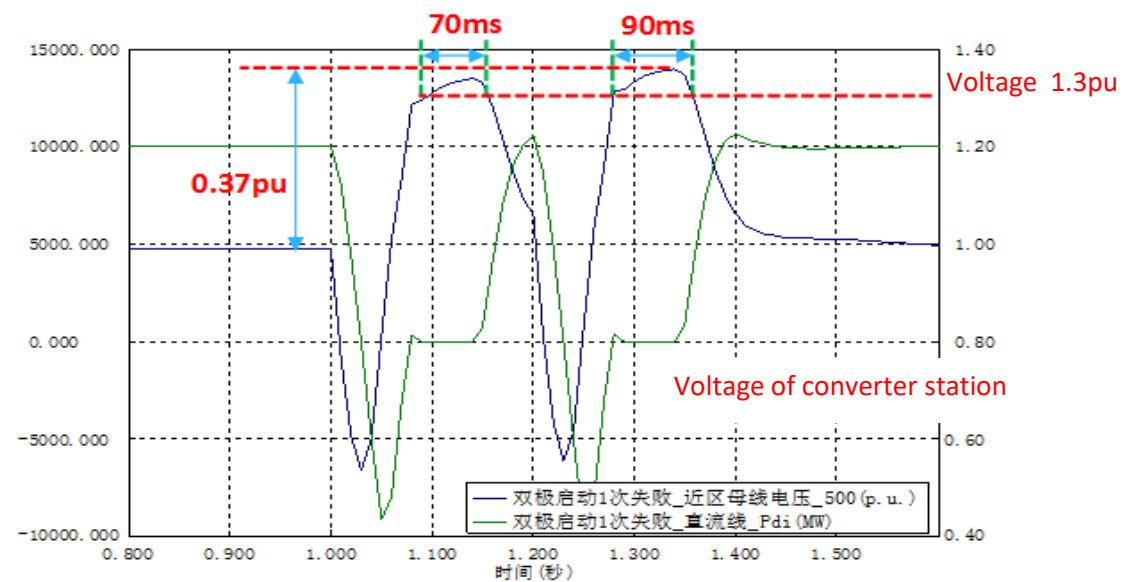
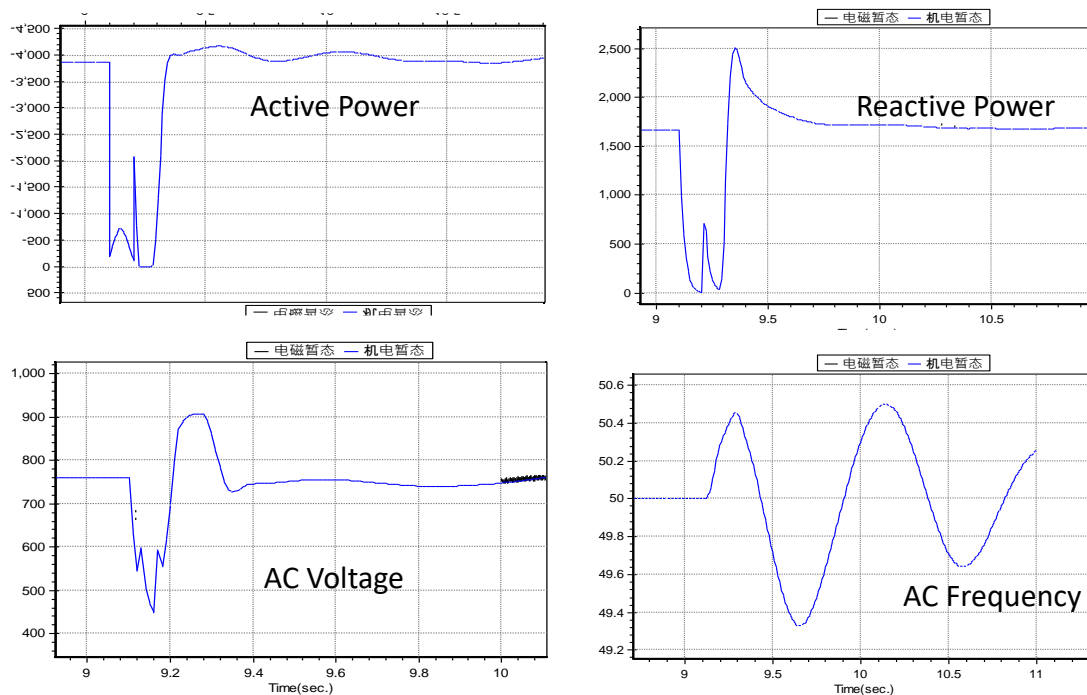

Over-voltage at sending AC side and transfer power variation of a UHVDC transmission system during 2 times successive commutation failures

2. RE power plants interaction with power grids

- ❑ In order to ensuring the bulk power system security and stability, the grid technical requirements (Grid Code, or Connecting Standards) to the renewable energy generation should be considering.
 - ✓ In the scenario of high wind and solar penetration, the system performance will be dramatically influenced, for example, the **system inertia** (rotating mass), capability for **frequency control** (governor), dynamic reactive power capacity are all declined, in order to guarantee the system stability, the Capability of **Fault Ride Through**, Controllability of wind and PV power plants are required, and the responsibility for voltage and frequency regulation should be partially undertook by wind and solar PV plants.
 - ✓ The interaction between renewable power generation & Power electronics and conventional power system (synchronous machines) are exacerbated, the synchronization scheme changed, stability characteristics changed, the new oscillation issue occurred more often (**SSCI, high frequency oscillation**), the requirements on countermeasures need to be considered to add into the Grid Code.

1

Impact of high penetration of RE generation

2

RE power plants interaction with power grid

3

Grid requirements upgrading and standardization

3. Grid requirements upgrading and standardization

- Chinese wind power grid code (2021 edition GB/T 19963.1)
 - Successive fault ride through, Inertia response and primary frequency control

ICS 27.180
CS F.31



中华人民共和国国家标准

GB/T 19963.1—2021
代替 GB/T 19963—2011

风电场接入电力系统技术规定
第 1 部分：陆上风电

Technical specification for connecting wind farm to power system—
Part 1: On shore wind power

2021-08-20 发布

2022-03-01 实施

国家市场监督管理总局
国家标准化管理委员会 发布

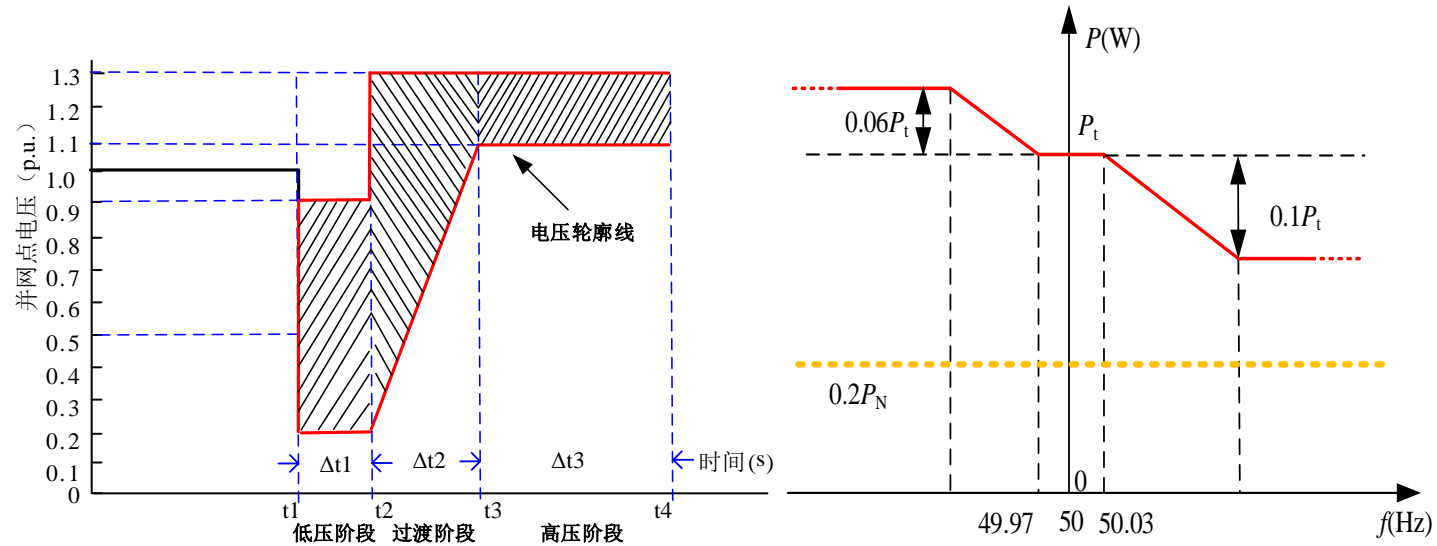

- UHVDC commutation failures cause over-voltage to 1.30 pu at the sending end of AC system, requirement of successive fault ride through are discussed and finally included in the new grid codes.
- Inertia response and primary frequency regulation are new added in grid code, wind farms shall be capable of participating system frequency regulation, with 6% headroom as the reserve for up-regulation.

3. Grid requirements upgrading and standardization

□ Title : Grid Integration of Renewable Energy Generation

- ✓ Secretariat :
China NC
- ✓ 21 P member, 9 O member
- ✓ 8 working group, 10 registered project



IEC SC 8A established in 2013, focusing on the impact of a high percentage of renewables connected to the grid, considering that their variability and predictability impact the functioning of the whole electricity grid.

Work scope covering the requirements for interconnection and related tests for grid code compliance, as well as standards or best practice documents for planning, modeling, forecasting, assessment, control and protection, scheduling and dispatching of renewables with a grid level perspective.

3. Grid requirements upgrading and standardization

□ IEC SC 8A/JWG 5 - System issues regarding integration of wind and PV generation into bulk electrical grid (IEC TR 63401-1, 2, 3, 4).

✓ Convenor: Mr. Jason MacDowell (US)

Prof. Jiabing Hu (CN)

✓ 76 members from 14 countries

✓ Project 1: Interconnecting Inverter-Based Resources to Weak AC Networks

✓ Project 2: Sub- and Super-synchronous Control Interactions

✓ Project 3: Fast Frequency Response and Frequency Ride-Through

✓ Project 4: Behavior of Inverter-Based Resources in Response to Bulk Grid Faults



INTERNATIONAL ELECTROTECHNICAL COMMISSION
TO ALL NATIONAL COMMITTEES
Technical committee 8: Systems aspects of electrical energy supply
Subcommittee 8A: Grid Integration of Renewable Energy Generation
Set up Joint Working Group (JWG 5): System issues regarding integration of wind and PV generation into bulk electrical grid and call for experts.
This document is also made available to TC 82, TC 88, TC 95, TC 114, TC 115, TC 117 and TC 129.

Dear Sir/Madam,

Background

During the 2017 IEC SC 8A plenary meeting in Vladivostok, Russian Federation, a decision was made to set up a new Joint Working Group, with the JWG 5: System issues regarding integration of wind and PV generation into bulk electrical grid, covering a series of possible projects within the following scopes:

(1) Weak AC Grid Connection and Special Application Issues
(2) Plant Level Interaction and Coordination Issues
(3) Voltage and Frequency Ride Through and Control Issues

After consulting with TC 82 and TC 88, it was agreed to set up the JWG 5, managed by SC 8A with the cooperation with TC 82 and TC 88, also nominate Mr. Jason MacDowell and Mr. Hu Jiabing as the co-convenors of JWG 5.

Title of JWG 5: System issues regarding integration of wind and PV generation into bulk electrical grid
Task of JWG 5: To develop a series of projects within the following scopes of weak AC grid connection and special application issues, plant level interaction and coordination issues, voltage and frequency ride through and control issues.

Membership:

- Co-convenors of JWG 5: Mr. Jason MacDowell (US)

Mr. Hu Jiabing (CN)

- Representatives from each P-member country of IEC SC 8A

Action

(1) National Committees are kindly invited to appoint experts, who should have expertise in the field of renewable energy grid integration and could make an effective contribution to the work of JWG 5. The appointed experts should be entered into the IEC Experts management system by the National Committees no later than 2018-06-22.
(2) The kick off meeting of JWG 5 was determined to be held in Wuhan, China on 20-21 June, 2018. Mr. Hu Jiabing are responsible for organizing the meeting and the logistics.

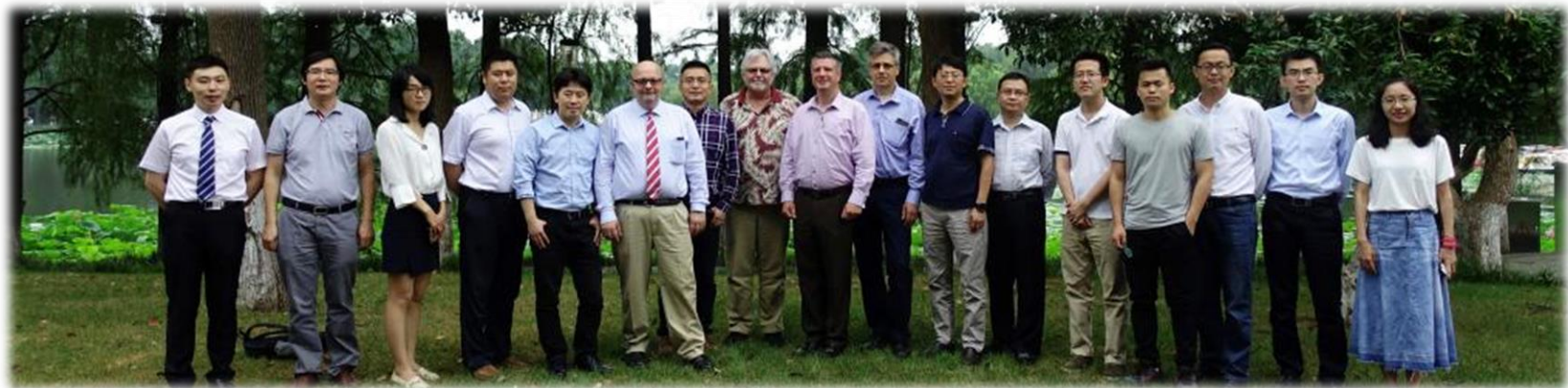

JWG 5 Kick off meeting in Wuhan, China, in 2018.

道阻且长 行则

The road is long and tough, but we will be there by keep walking!

将至!

Thanks!

Email: chiyongning@icloud.com

Mobile: 0086 10 18613838518

