



U.S. DEPARTMENT OF
ENERGY

unifi
consortium

universal interoperability
for grid-forming inverters

UNIFI Consortium Overview

Ben Kroposki

UNIFI Organizational Director

March 2022



universal interoperability
for grid-forming inverters

Future power systems with any mix of machines and IBRs at any scale that are affordable, secure, reliable, clean, and resilient **Vision**

Forum to address fundamental challenges in seamless integration of grid-forming (GFM) technologies into power systems of the future **Purpose**

Conduct research and development, demo concepts at scale, author best practices and standards, train next-generation workforce **Goal**

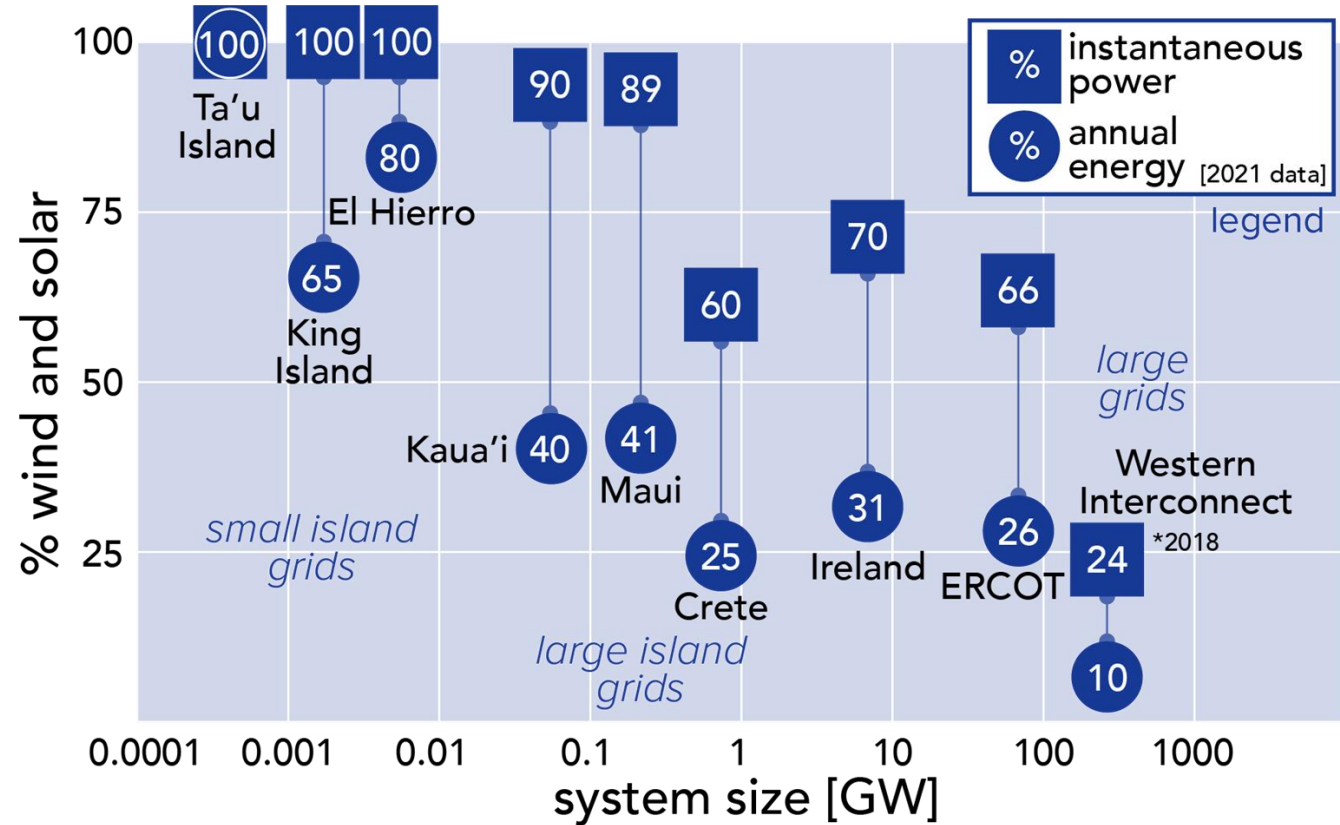

IBRs = inverter-based resources



universal interoperability
for grid-forming inverters

Future power systems with any mix of machines and IBRs at any scale that are affordable, secure, reliable, clean, and resilient **Vision**

Forum to address fundamental challenges in seamless integration of grid-forming (GFM) technologies into power systems of the future **Purpose**

Conduct research and development, demo concepts at scale, author best practices and standards, train next-generation workforce **Goal**

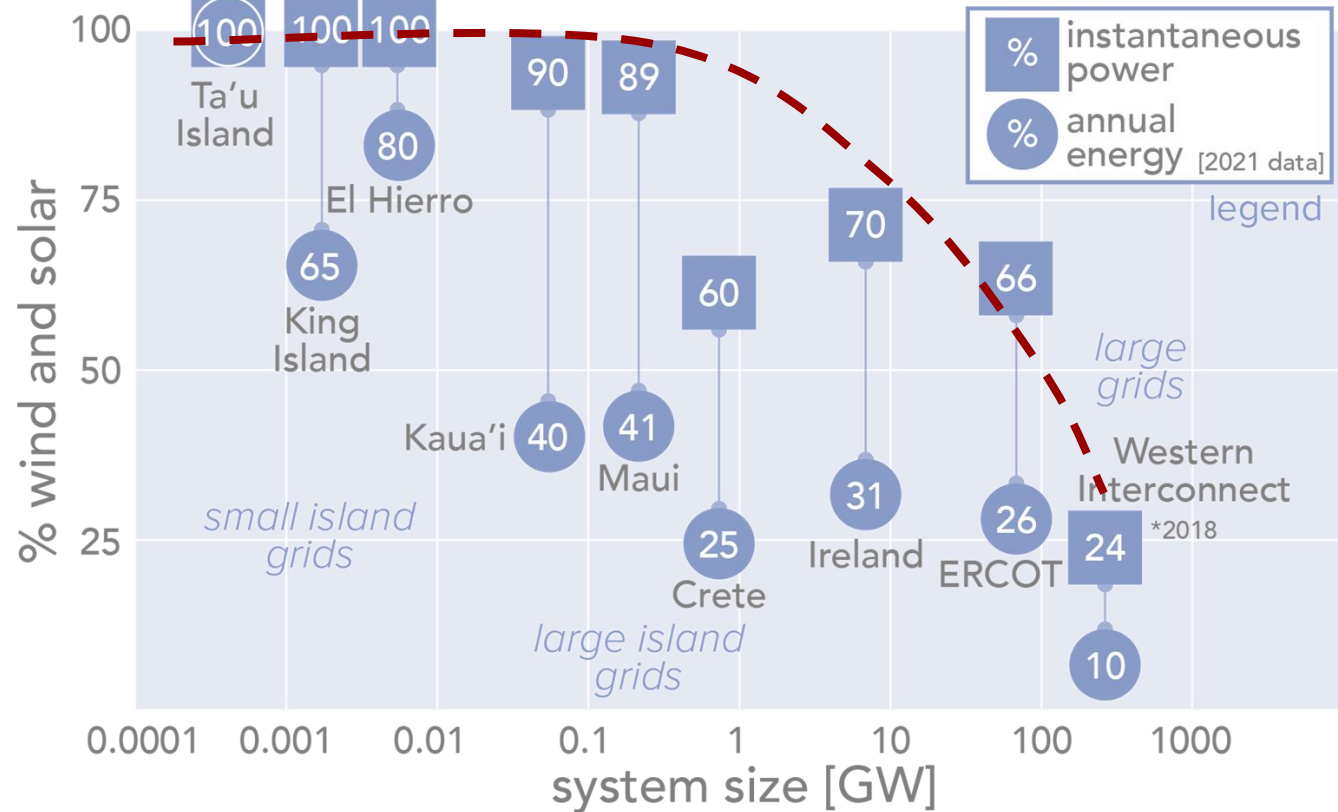

IBRs = inverter-based resources



universal interoperability for grid-forming inverters

Future power systems with any mix of machines and IBRs at any scale that are affordable, secure, reliable, clean, and resilient

Vision

Forum to address fundamental challenges in seamless integration of grid-forming (GFM) technologies into power systems of the future

Purpose

Conduct research and development, demo concepts at scale, author best practices and standards, train next-generation workforce

Goal

IBRs = inverter-based resources

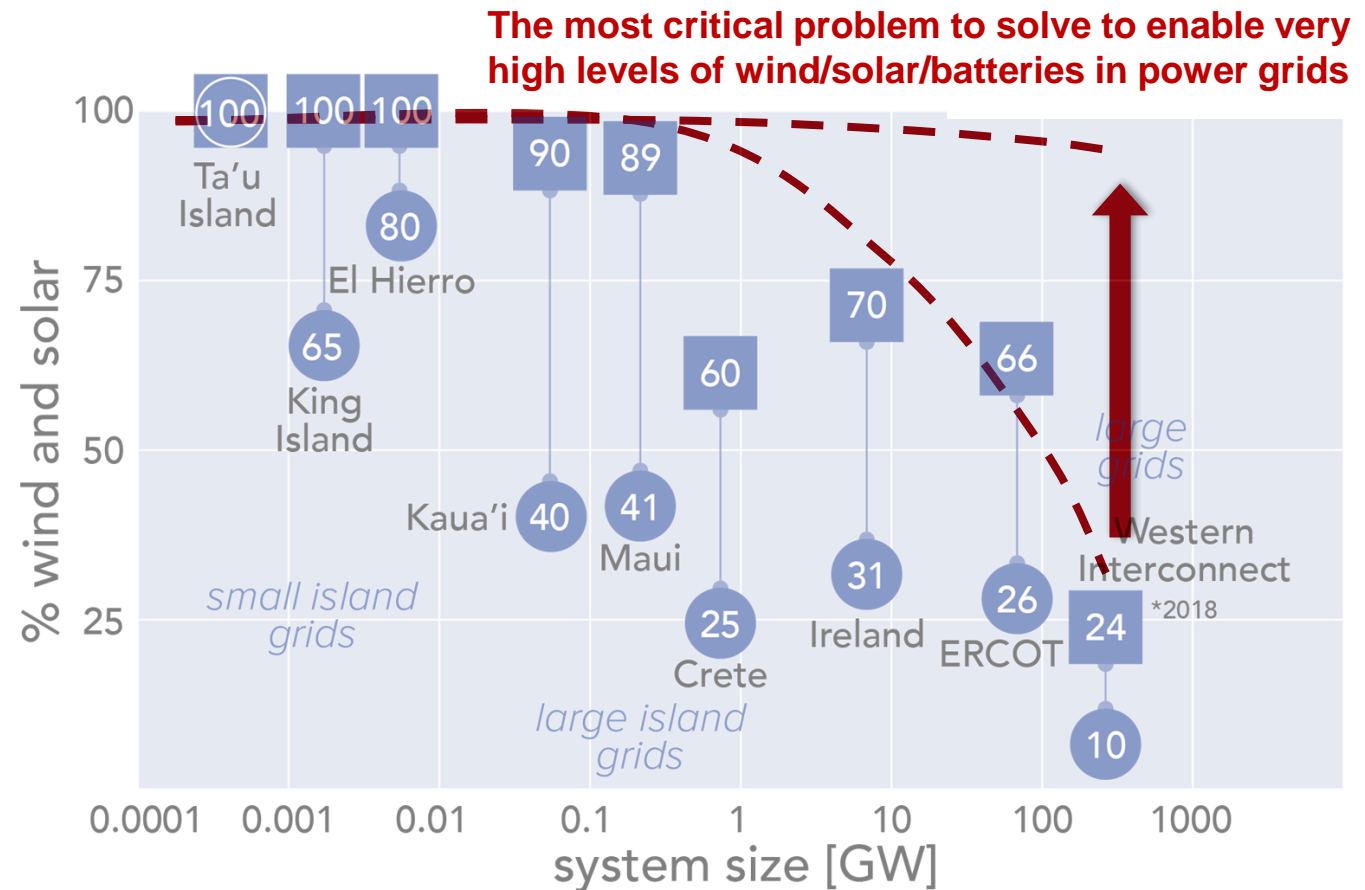

Global Landscape

Grid codes and roadmaps around the world recognize the role for (and of) grid-forming (GFM) inverter-based resources (IBRs)

Challenges

- Poor definitions of capability and functionality across technologies; lack of standardization
- Limited-to-no consensus on expected performance from unit and system levels
- Vendors/Manufacturers and Utilities/Operators appear to be locked in circular death spirals

Solution (@ a snapshot)

- Interoperability drove interconnections in the past
- Interoperability will drive innovation into the future

Research Roadmap on Grid-Forming Inverters



High Penetration of Power Electronic Interfaced Power Sources and the Potential Contribution of Grid Forming Converters

Technical Report



Application of Advanced Grid-scale Inverters in the NEM

August 2021

White Paper

An Engineering Framework: report on design capabilities needed for the future National Electricity Market



Yashen Lin,¹ Joseph H. Eto,² Brian B. Johnson,³ Jack D. Flicker,⁴ Robert H. Lasseter,⁵ Hugo N. Villegas Pico,⁶ Gab-Su Seo,⁷ Brian J. Pierre,⁸ and Abraham Ellis⁹

With editing and support from Hariharan Krishnaswami,¹⁰ Jeremiah Miller,¹¹ and Guohua Yuan¹²

¹National Renewable Energy Laboratory
²Lawrence Berkeley National Laboratory
³University of Washington
⁴Sandia National Laboratories
⁵University of Wisconsin
⁶University of Wisconsin
⁷U.S. Department of Energy Solar Energy Technologies Office



What is UNIFI ?

The **UNIFI Consortium** is a forum to address fundamental challenges in the seamless integration of grid-forming (GFM) inverter-based resources (IBR) into power systems of the future

Bringing the industry together to unify the integration and operation of inverter-based resources and synchronous machines

Three major focuses:

- Research & Development
- Demonstration & Commercialization
- Outreach & Training

DOE is funding a 5-year project to kick-start work – Plan to create a sustainable organization through memberships

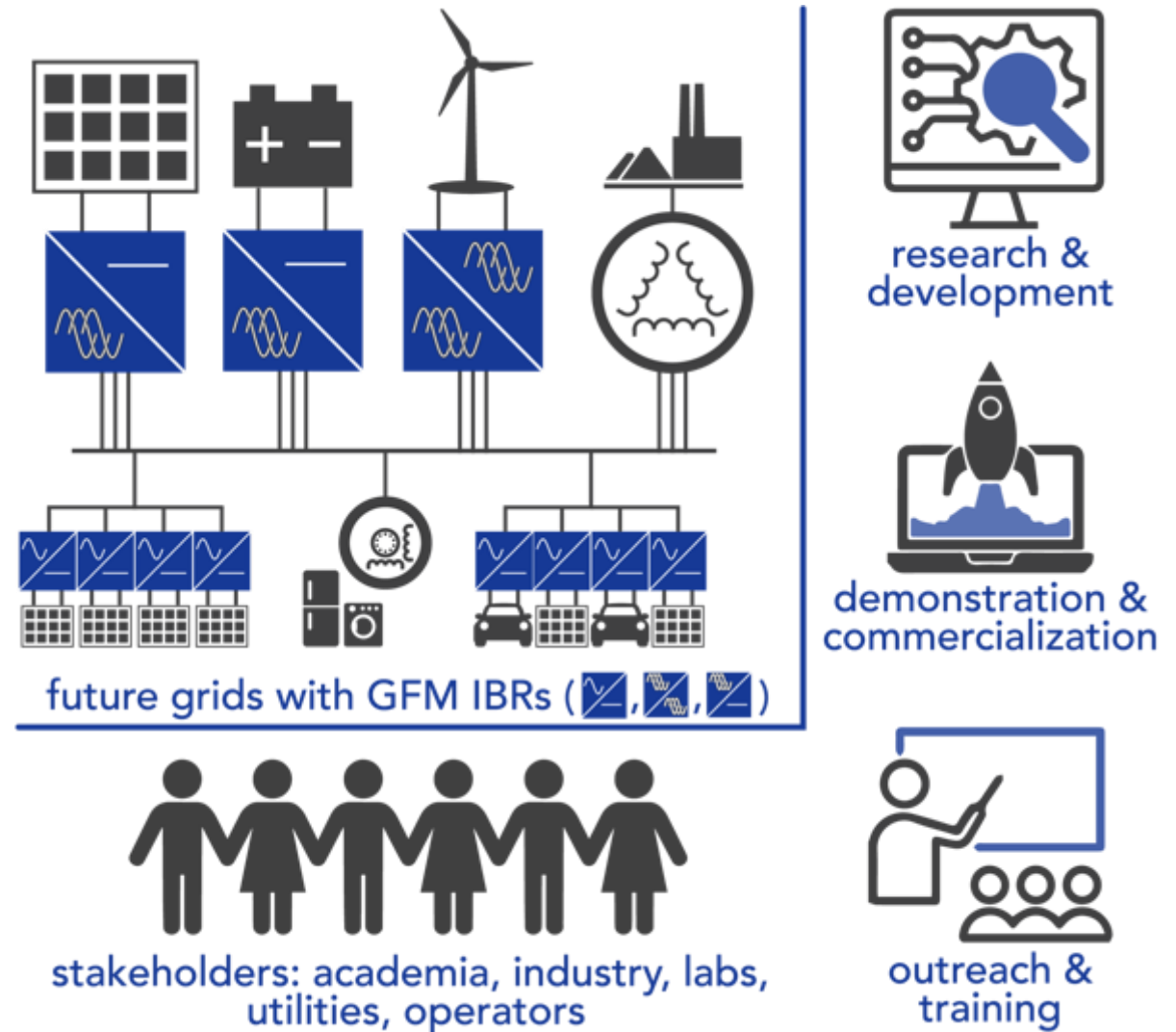

Envisioned System Architecture

- GFM technologies: individual **GFM IBRs** (at sufficiently high capacity), **plants** (e.g., utility-scale PV/wind), or **aggregations** (e.g., heterogeneous units at distribution level)
- Unit-level functionality includes vendor-specific proprietary controls aided by a middle-layer (labelled **interoperable GFM controls**) that translates system-level control objectives
- Exchange standardized signals through suitable interface (**signal I/O**) in a cyber-secure manner with the system operator to regulate frequency & voltages via secondary control, and manage operations (e.g., black-start)
- Distributed optimization and control algorithms within and across control areas (**balancing areas**) may be required
- Will require both unit-level and system level advances

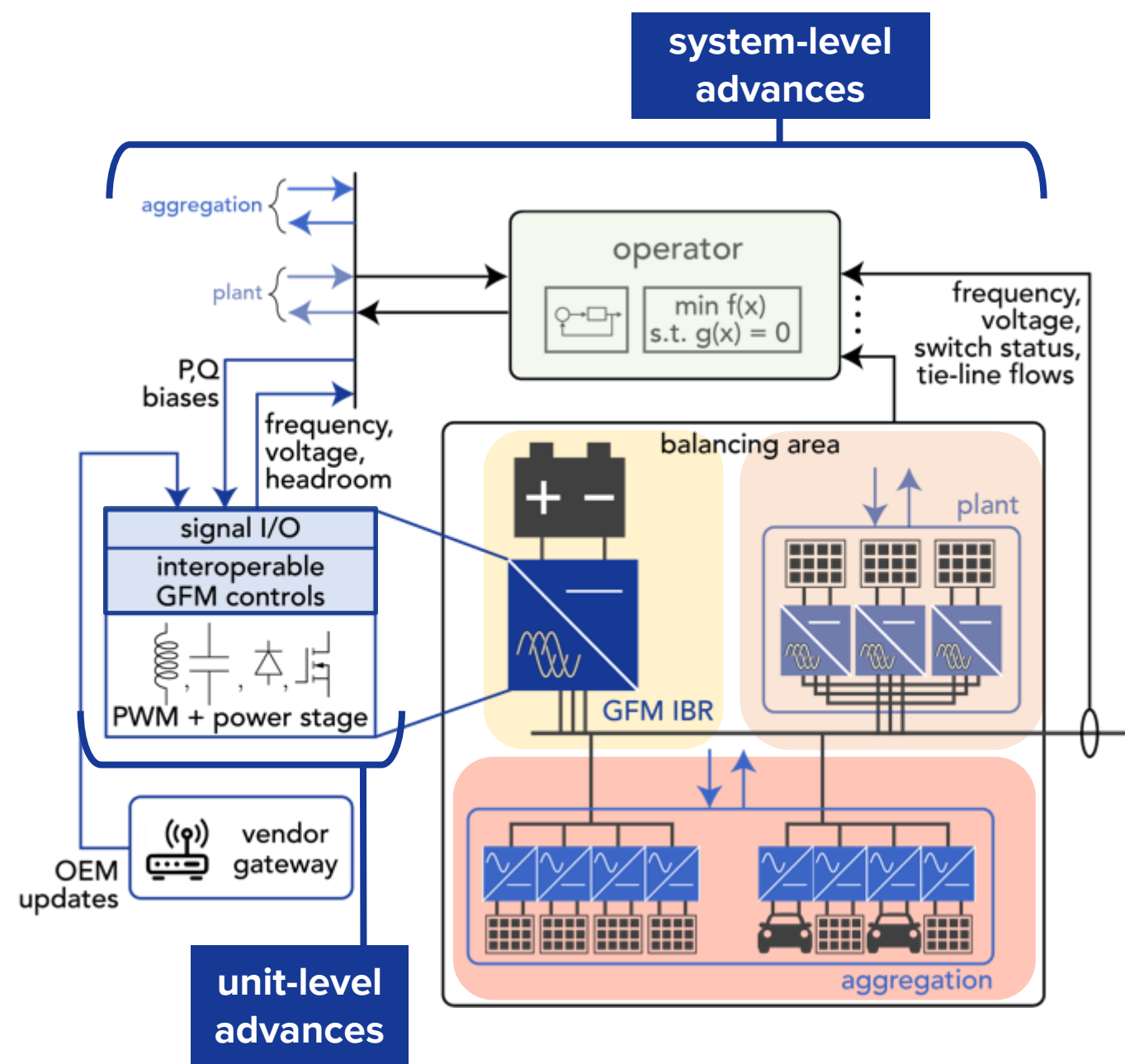

GFM = grid-forming inverter IBRs = inverter-based resources

UNIFI Goals

Curate vendor- and technology-agnostic **“UNIFI Specifications”** that standardize performance and benchmark capabilities of GFM technologies across scales

- **Interoperability Guidelines (@ system level)** - that promote the coordinated and seamless operation of GFM technologies from multiple vendors while ensuring stable and reliable power grids
- **Functional Requirements (@ IBR level)** – that define GFM-IBR capabilities which are specified in a vendor-agnostic fashion to satisfy all system-level interoperability guidelines

Convene continuous collaboration between inverter manufacturers (on one end) and system operators and utilities (on the other) to bridge gaps between power-systems and power-electronics industries

Cultivate inclusive culture and leverage member cooperation for sustained innovation

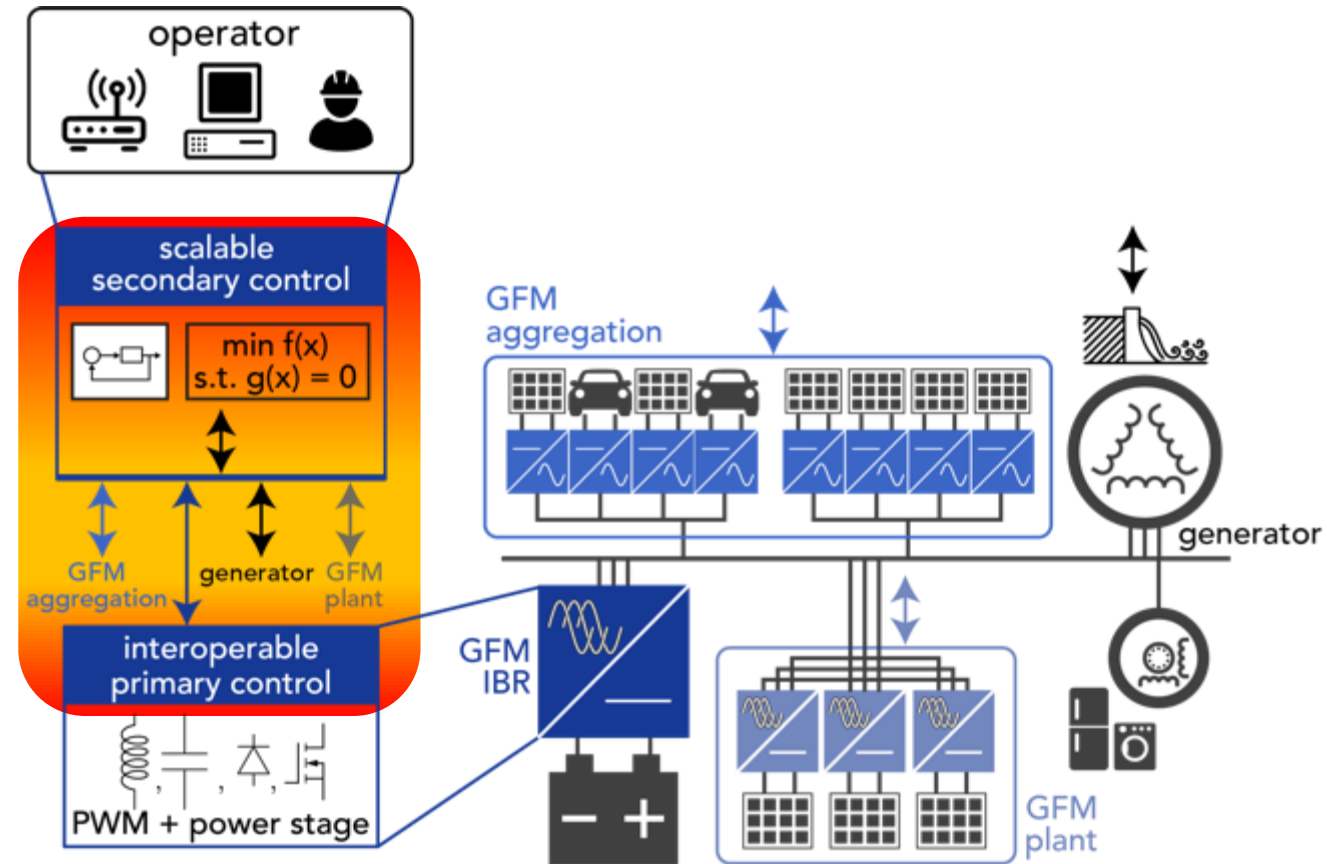

Timeline to Date

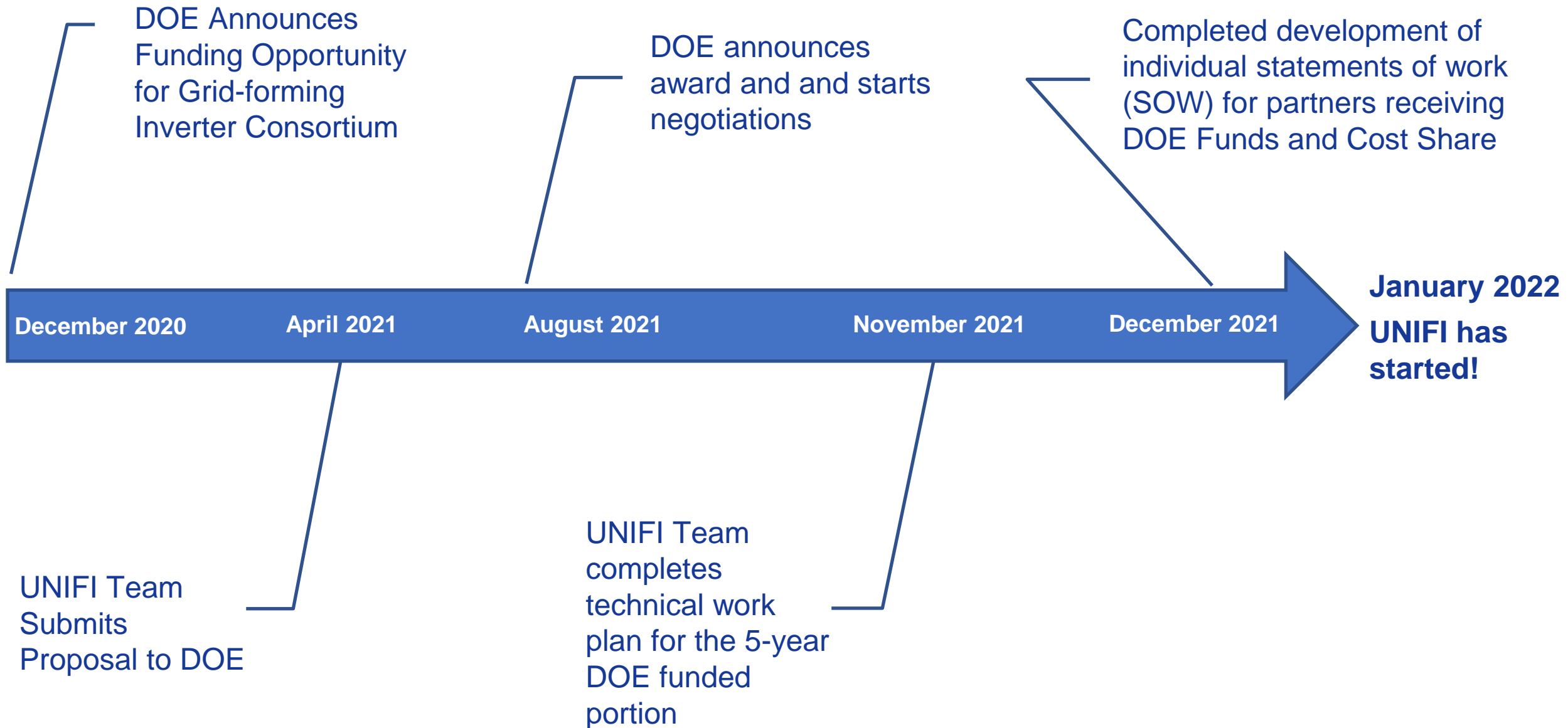

UNIFI Organizational Structure

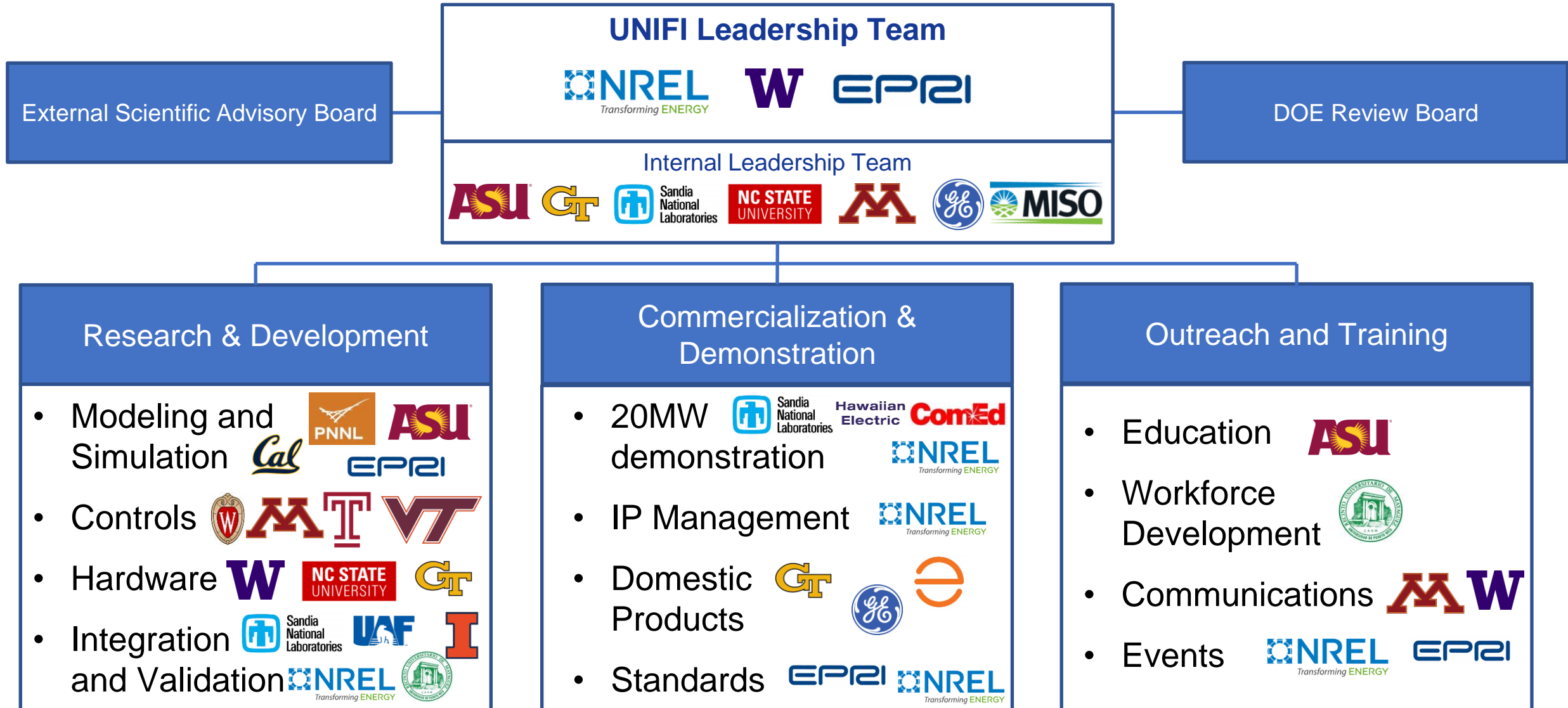

UNIFI Working Groups (WG)

- UNIFI Specifications
 - Interoperability and Functional Requirements WG (defines interoperability, maintains rules, manages Core IP)
- Modeling and Simulation Area
 - GFM Model Development and Theoretical Innovations WG
 - Use Case, Software Testbed, and Interoperability
- Controls Area
 - Real-time Control and Dynamic Stability WG
 - Communication-coordinated Control and Cybersecurity WG
- Hardware Area
 - Open-source Code Development and Experiment Planning & Design WG
- Integration and Validation Area
 - Validation of UNIFI Specifications WG
 - 1MW Multi-vendor Experiment WG
- 20MW Demonstration Area
 - 20MW Demo Specifications WG
- Standards Area
 - Standards Coordination WG
- Education Area
 - Education WG
- Workforce Development Area
 - Seminar Series WG
 - Tutorials WG

UNIFI Members - Project Team

National Labs & Research Institutes

NRE EPRI
Transforming ENERGY

Sandia National Laboratories

PNNL

BERKELEY LAB

Universities

W M NC STATE UNIVERSITY

Cal I

ASU GT

UAF VT



Industry

GE

Eaton

Danfoss

Hitachi Energy

OPAL-RT TECHNOLOGIES

Typhoon HIL

Utilities & System Operators

SOUTHERN CALIFORNIA EDISON

Hawaiian Electric

PG&E Xcel ENERGY MISO

Southern Company

New York Power Authority ComEd PGE

CAISO PACIFICORP ISO new england

Additional Partners



- Participation confirmed through Letters of Support
- Representative of potential additional Consortium members, facility users, sponsors of directed R&D
- Emphasize strong ties with other relevant Consortia from inception to ensure unique positioning

Research & Development (R&D) Thrust

- **At-a-Glance:**
 - **Modeling & Simulation:** GFM-specific dynamics, bridge gaps to HIL
 - **Controls:** Unit- and system-level, Stability, Cybersecurity
 - **Hardware:** Anticipate industry needs, Develop open-source prototyping
 - **Integration & Validation:** Conduit to demonstrations, 1MW experiment at NREL
- **Features:**
 - Establish core technical capabilities in critical technical areas
 - Leadership provided by experts across academia, labs, industry
 - Emphasize interoperability across portfolio of solution sets



Modeling & Simulation Area

Snapshot of Innovations:

- Interoperability standards and application programming interfaces (APIs) to allow GFM models to be directly used by different software vendors
- Develop HIL-compatible software models:
 - Hybrid between virtual power stage model & controller in the loop
 - Integrated into commercial and open-source simulation tools
- Model interoperability tests on a virtual platform that provides a secure workspace for tool vendors and a means for utilities to participate and evaluate solutions
- UNIFI has partnerships and collaborations with **all** commercial power-system simulation-software vendors that cover timescales ranging from real-time through micro-/milli-second simulations:
 - EMT simulation (PSCAD, EMTP, HYPERSIM, PLECS)
 - Positive-sequence simulation (PSLF, PSS/E, TSAT, PowerWorld)
 - Real-time simulation (Opal-RT and Typhoon HIL)

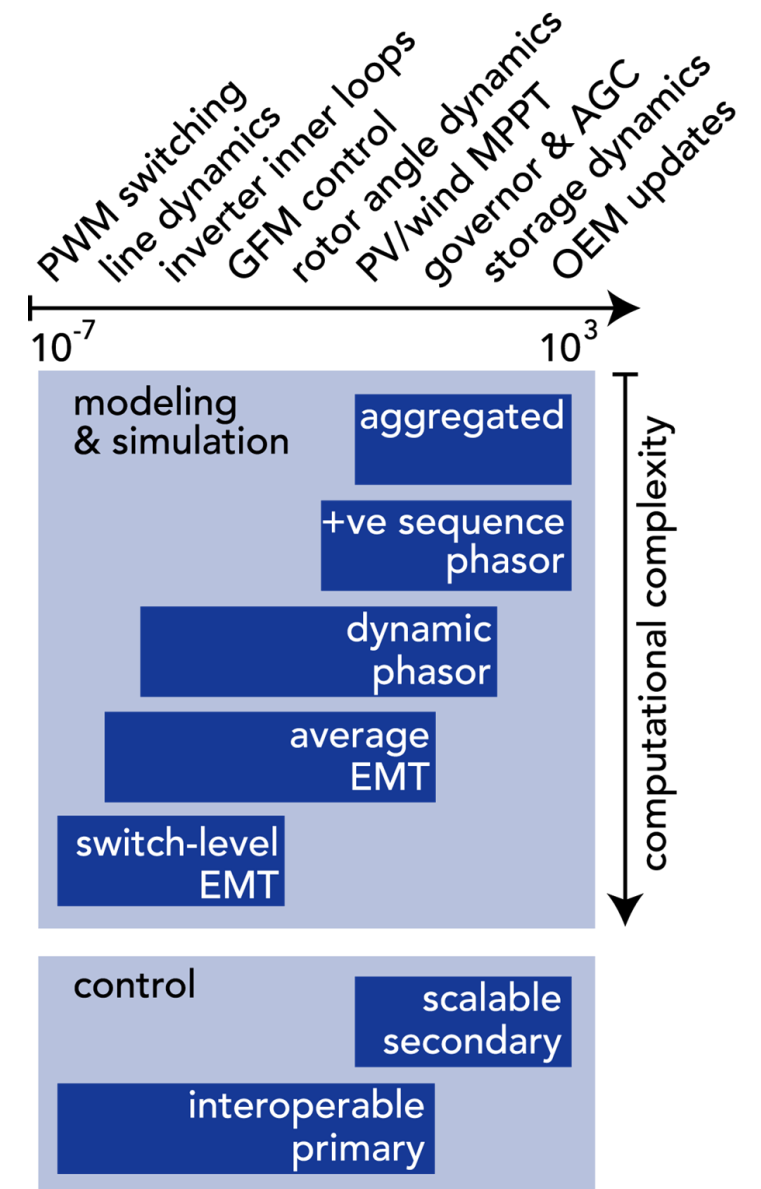

Controls Area

Snapshot of Innovations:

- **Interoperable GFM primary-control architecture:**
 - Compatible with generation and storage technologies via vendor-agnostic middle-layer that translates system-level control signals
 - Coordinates energy transfer within hybrid IBR-plants, large-scale PV, and wind energy conversion systems while managing IBR-level source-side and inverter limits
- **Scalable secondary-control architecture:**
 - Generalize area control error (ACE) beyond frequency (to include, e.g., voltage magnitude, phase imbalance)
 - Coordinate and prioritize between different balancing areas while accounting for IBR limits

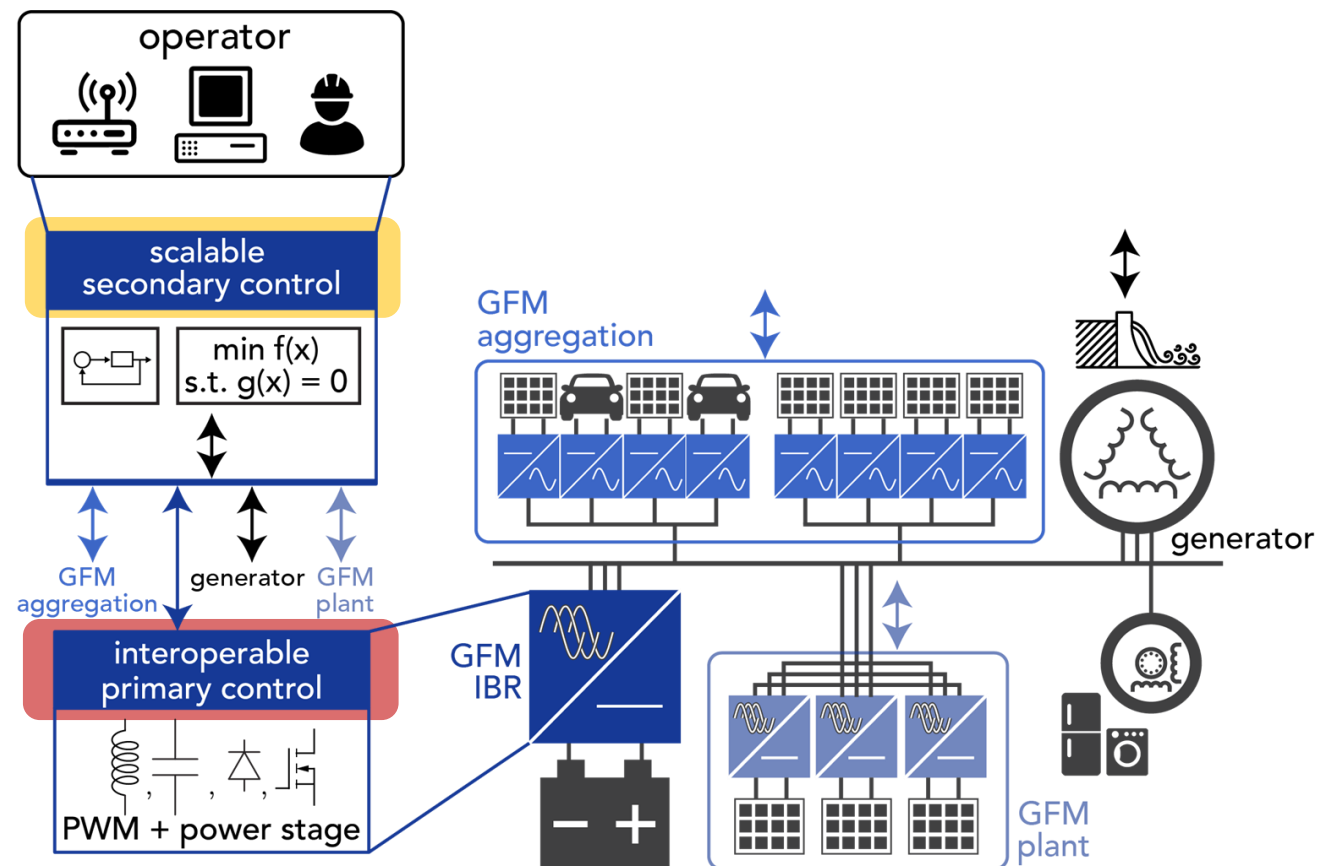

Integration & Validation Area

Snapshot of Innovations:

- Federate and standardize testing and characterization facilities across partnering institutions
- Use cases → testing, evaluation, communication protocols → certification-type testing environment → user facilities for fee

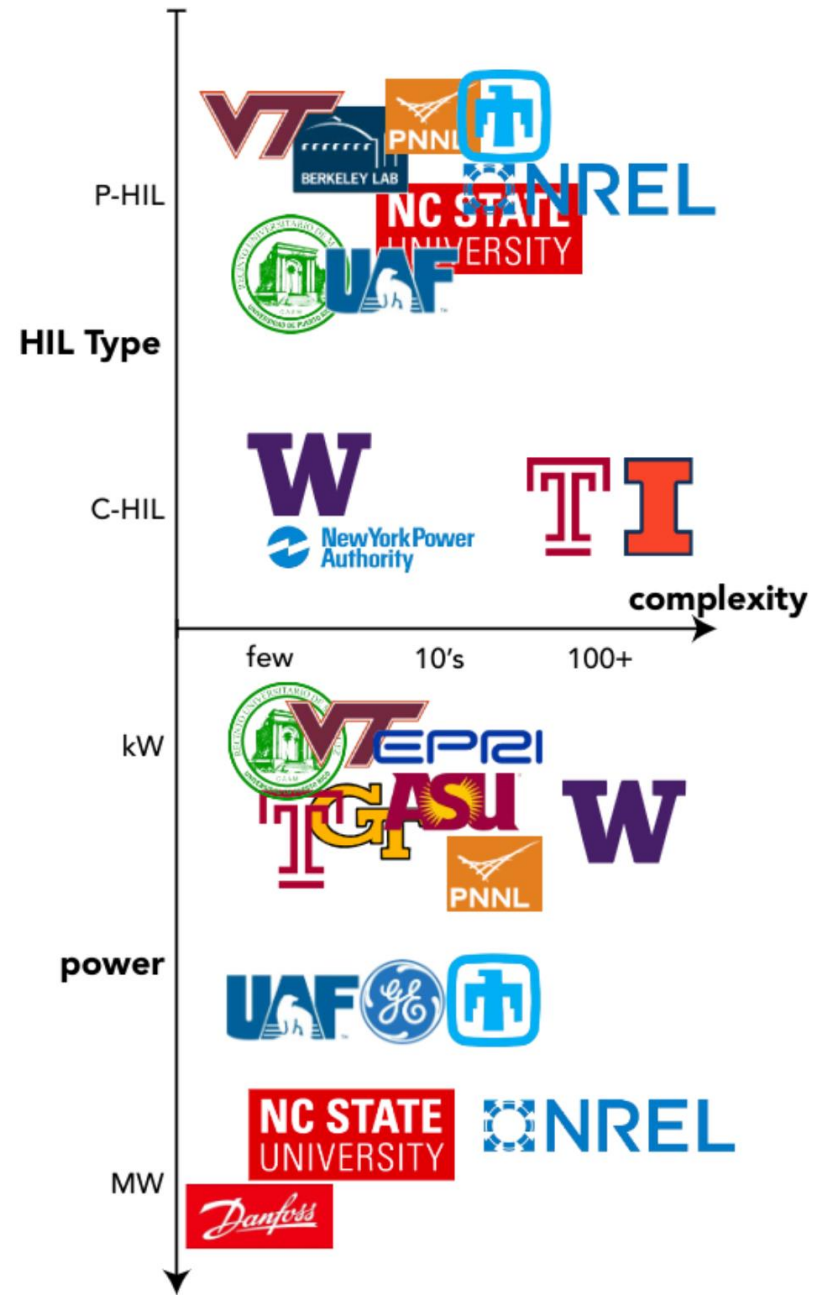
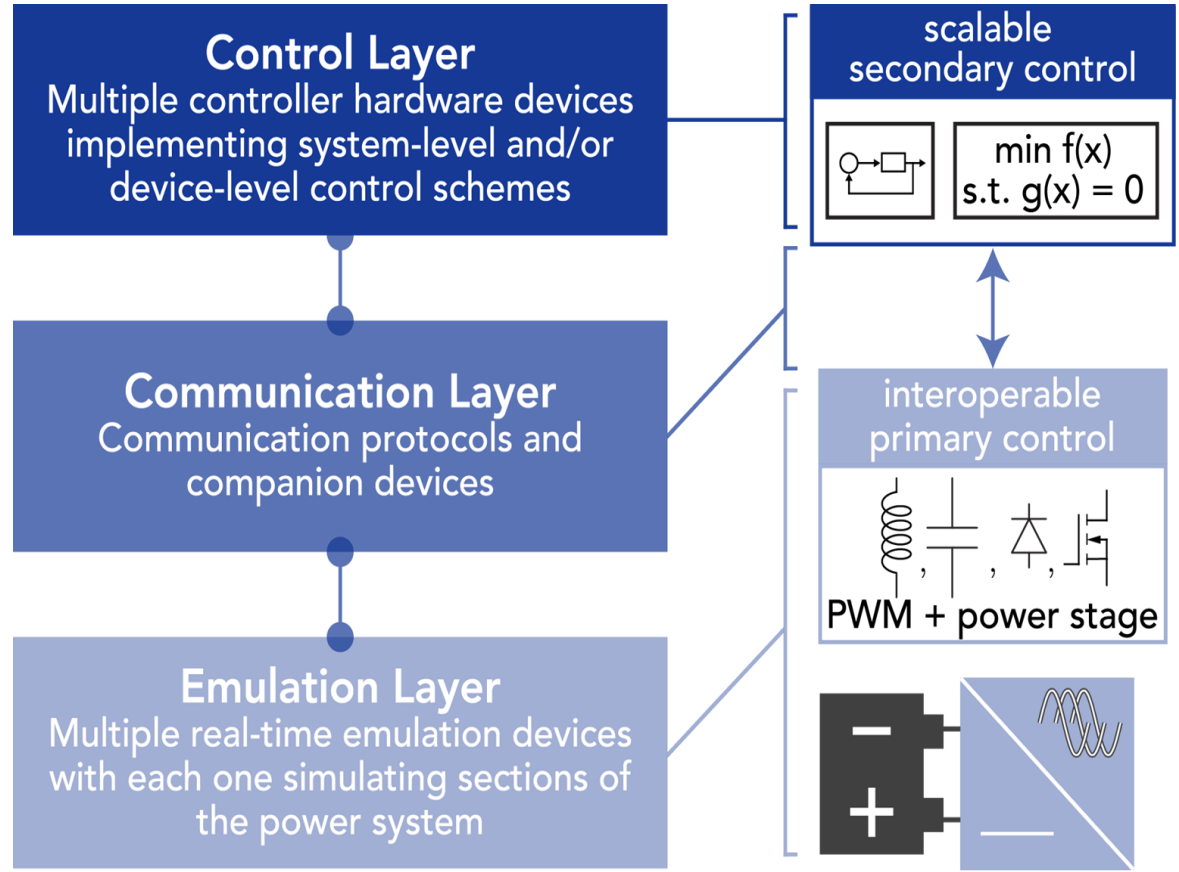

Integration & Validation Area

1 MW Experiment – at NREL in Year 3

- Create a hardware testbed that all vendors that follow the UNIFI Specifications for interoperability should be able to plug and play with other vendors
- Includes various physical sizes (250W-1MW)
- Three-phase, single-phase generation & loads
- Multiple source-side resources (PV, energy storage, wind (if possible))
- 50%, 75%, 90%, and 100% power contribution from GFM IBRs
- Connections to multiple laboratories: integrated testing and validation approach to realize multiple 1MW demos



Demonstration & Commercialization (D&C) Thrust

- At-a-Glance:
 - **20+MW Demo:** flagship UNIFI outcome
 - **IP Management:** collaborative IP to focus on interoperability
 - **Domestic Products:** position US as world leader in PV, wind, and storage
 - **Standards:** align with technology cycles via emphasis on interoperability
- Features:
 - Conduit to transition R&D to commercial products and applications
 - Leadership by experts who have built startups and led acquisitions
 - Testing grounds to evaluate broad impact across industries
 - Extensive experience with standards development organizations



20+MW Demonstration



Large-scale Plant Integration
[Barilla Solar, TX]

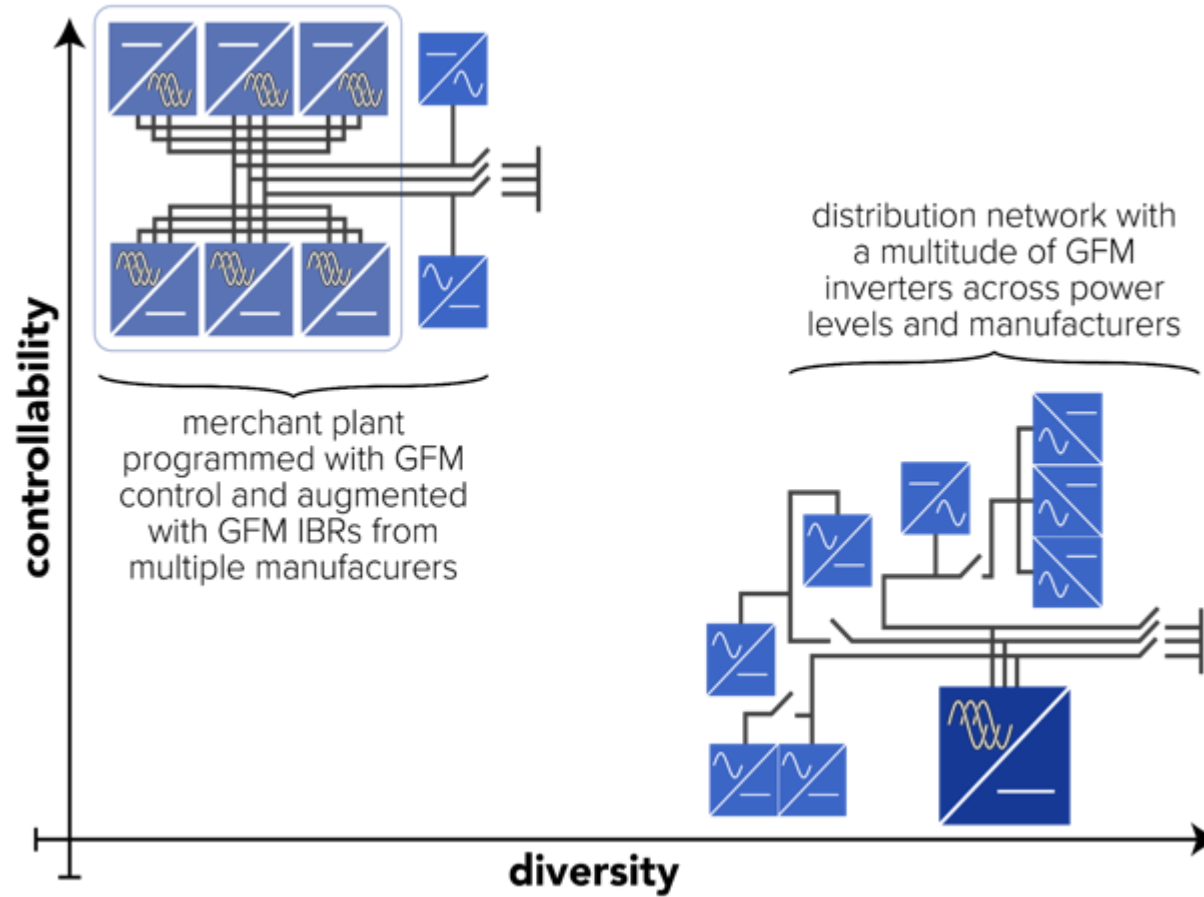

Distribution Networks with high PV integration



[Chicago, IL]



[Oahu, HI]

- Examining a range of possible sites that trade off controllability and diversity of resources and IBR size
- Also looking for demonstrating much larger than 20MW sizes and at possibly at multiple sites
- Demonstrate a full range of GFM services and validate *Interoperability Guidelines & Functional Requirements*
- Would like to examine unique objectives if possible such as energy justice (collocate with underserved communities)

20+MW Demonstration

We are looking for sites that include some or all of the following:

- a mix of three-phase/single-phase resources
- a mix of GFM IBRs, GFL IBRs, and machines
- devices that have a wide range of power ratings (from 250W to MW)
- solutions from multiple vendors a plurality of source-side energy sources (PV, energy storage, wind)
- plant-level controls and SCADA as required
- range of load types and sizes (resistive/inductive, single-/three-phase)

Would like to validate the UNIFI system interoperability guidelines and functional requirements

- interoperable and scalable primary and secondary control
- frequency and voltage control
- power sharing among units
- black-start
- transient operation during balanced and unbalanced faults
- operations to achieve up to 100% power contribution from IBRs during medium- and high-demand periods

Let us know if you have potential demonstration sites

Prior Work



Demonstration of Essential Reliability Services by a 300-MW Solar Photovoltaic Power Plant

Clyde Loutan, Peter Klauer, Sirajul Chowdhury, and Stephen Hall
California Independent System Operator

Mahesh Morjaria, Vladimir Chadliev, Nick Milam, and Christopher Milan
First Solar

Vahan Gevorgian
National Renewable Energy Laboratory

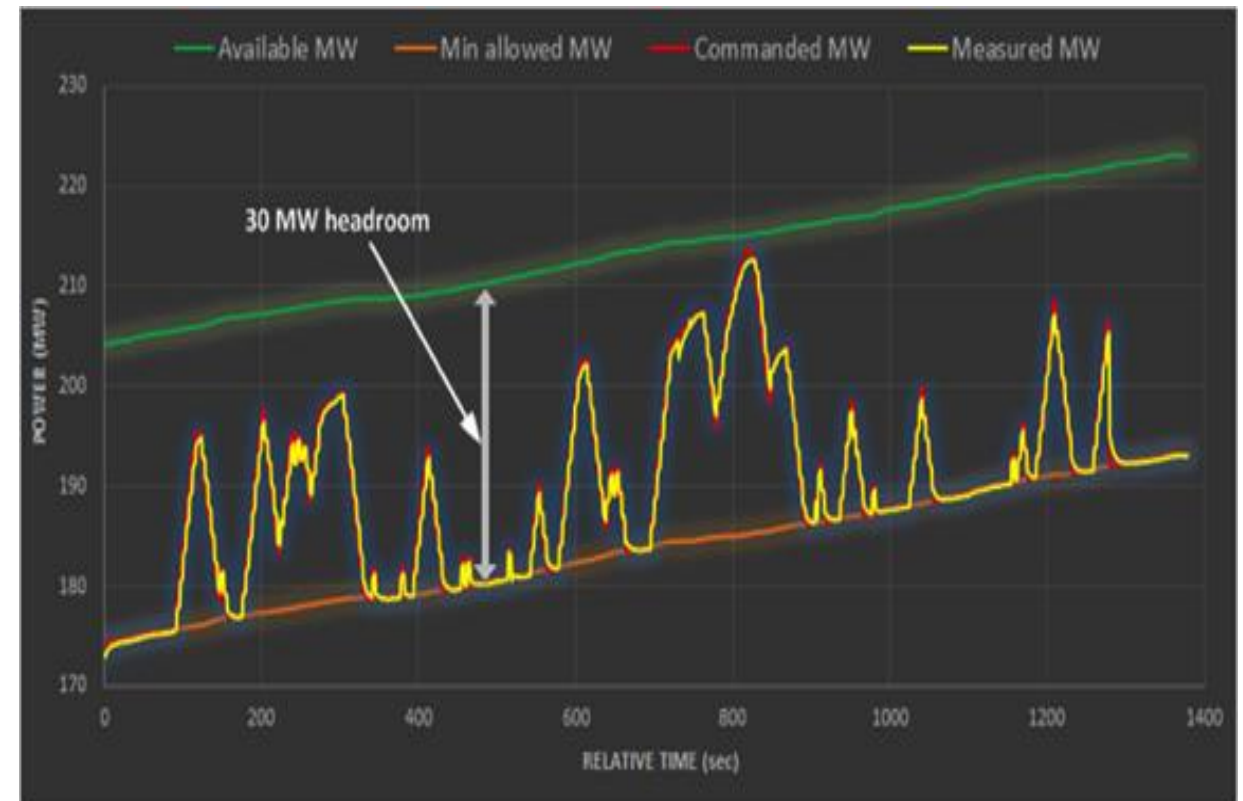

NREL/FirstSolar/CAISO experiment: 300-MW plant following Automatic Generator Control (AGC) signal

Source: C. Loutan, P. Klauer, S. Chowdhury, S. Hall, M. Morjaria, V. Chadliev, N. Milam, C. Milan, V. Gevorgian, *Demonstration of Essential Reliability Services by a 300-MW Solar Photovoltaic Power Plant*, <http://www.nrel.gov/docs/fy17osti/67799.pdf>

IP Management and Product Development

- UNIFI plans to work with members to determine and develop “Core Stack” IP that will enable GFM technologies to meet the Interoperability Guidelines and Functional Requirements
- Ensure that members have ability to meet UNIFI Specifications

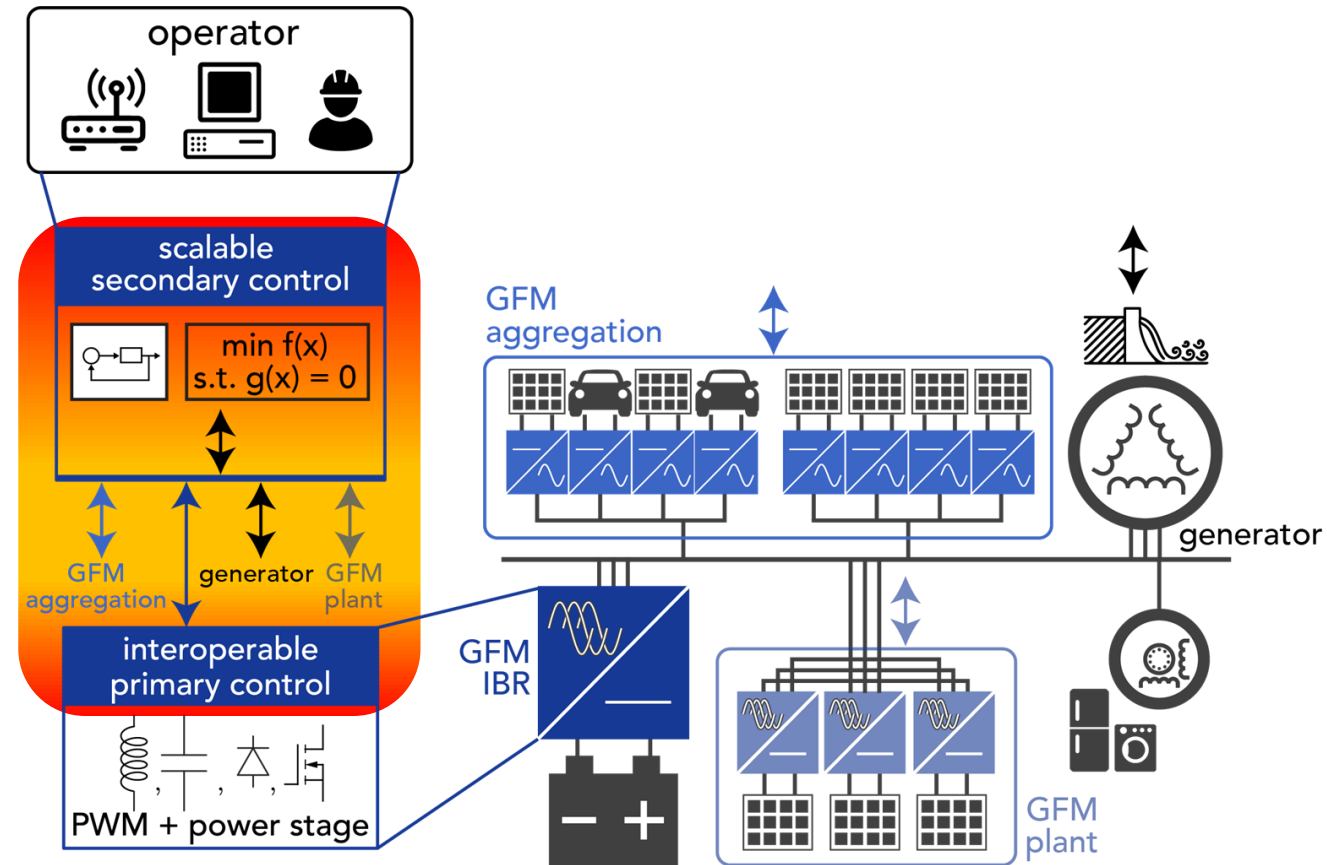

Standards

- Current standards for interconnecting IBR to power systems do not specifically address GFM technologies
 - IEEE 1547 - Distribution
 - IEEE P2800 - Transmission
- Conducting a gap analysis on existing IEEE 1547 and 2800 standards along with development of technical minimum capabilities for GFM devices
- UNIFI will focus on developing specification for GFM technologies
- Working closely with Standard Development Organizations, UNFI will bring expertise on GFM to future updates of these standards

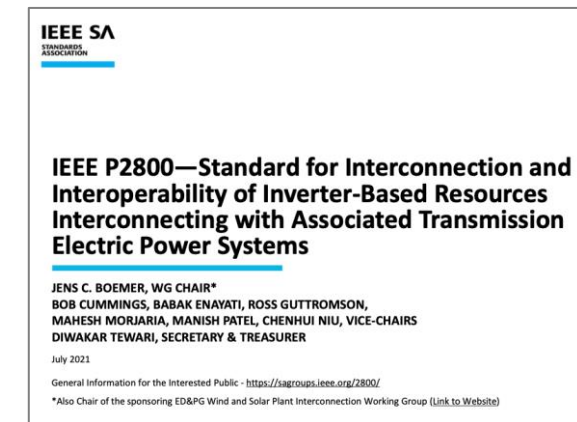
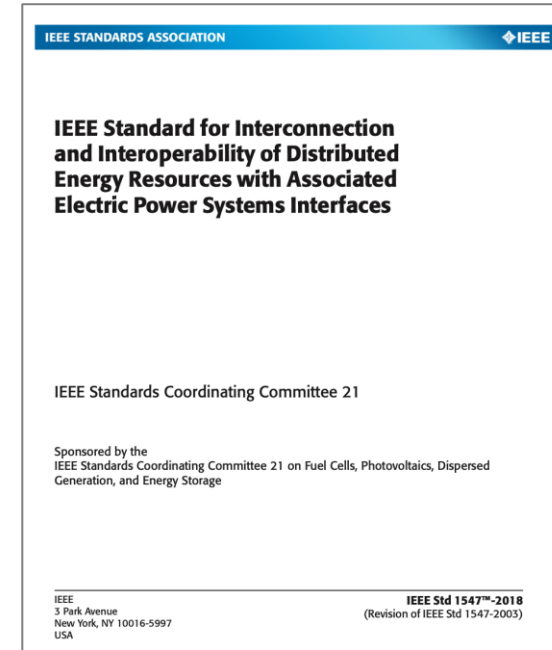

Outreach & Training (O&T) Thrust

- At-a-Glance:
 - **Education:** certificate program, summer program, half-day certification for teachers
 - **Workforce development:** short courses & tutorials, safety-certification courses
 - **Communication:** website and e-newsletter(s)
 - **Events:** annual meetings, webinars
- **Features:**
 - Cultivate inclusive culture with focus on diversity going beyond academic minority serving institutions (MSI)
 - Leverage institutional resources for free exchange of people and ideas



2022 IEEE Power & Energy Society General Meeting (GM)

17 – 21 July 2022 | Denver, Colorado



<https://pes-gm.org>

Outreach & Training (O&T) Thrust



Industry-led training events



Interoperability Events



Workshops (in person!)



Leverage Institutional partnerships

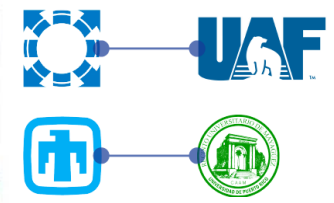

UNIFI Seminar Series

15 seminars every Spring and Fall for the next 5 years – Mondays at 4-5pmET/1-2pmPT

unifi consortium
universal interoperability for grid-forming inverters

Fall 2021 Seminar Series on Grid-Forming (GFM) Technologies

Who Organized by UNIFI (see [here](#)) & UC Berkeley
Where Zoom • Register [here](#)
When Mondays in the Fall
4-5 ET • 3-4 CT • 2-3 MT • 1-2 PT
Contact Duncan Callaway • dcal@berkeley.edu

Berkeley
UNIVERSITY OF CALIFORNIA
ENERGY MODELING, ANALYSIS, & CONTROL
ENERGY & RESOURCES GROUP

Aug 20 • Ben Kroposki (NREL) The Need for Grid-Forming Inverters in the Future Power System	Nov 1 • Deepak Ramasubramanian (EPRI) Modeling & Control of Grid-Forming Inverters for Large System Studies
Sep 13 • Deepak Divan (Georgia Tech) Realizing Grid-Forming Inverters at Scale: Challenges & Opportunities	Nov 8 • Ivan Celanovic (Typhoon) & Humberto Pinheiro (UFSM) Primary Controllers for Grid-Forming Converters
Sep 20 • Julia Matevosyan (ERCOT) Survey of Grid-Forming Inverter Applications	Nov 15 • Brian Johnson (UW-Seattle) Experiments to Accelerate Innovation in Grid-Forming Inverter-based Power Systems
Sep 27 • Julie Cohn (U-Houston) The Grid: Biography of an American Technology	Nov 22 • Isbel Husain (NCSU) Grid-Forming Converters for Ride-Through of Symmetric and Asymmetric Faults
Oct 4 • Donny Zimmerman (Enphase) Plug and Play: Creating a Simple and Universal Inverter Microgrid Ecosystem	Nov 29 • Mariko Shirazi (U-Alaska Fairbanks) Operation of Grid-Forming Inverters in Today's Diesel-based Microgrids
Oct 11 • Saijaj Dhole (U-Minnesota) Power system Modeling for the Era of Inverter-based Resources	Dec 6 • Ulrich Muenz (Siemens) Dynamic Security Optimization for N-1 Secure Operation of Hawaii's Power Systems with 100% Inverter Based Resources
Oct 18 • Vijay Vittal (Arizona State) WECC Models for Representing Inverter Interfaced Generation in Transient Stability Studies	Dec 13 • Vahan Gevorgian (NREL) Large-scale Grid-Forming Inverter Experiments at NREL
Oct 25 • Dominic Gross (U-Wisconsin Madison) Rethinking GFM Control: A Universal Control Paradigm and Protection Challenges	

unifi consortium
universal interoperability for grid-forming inverters

Spring 2022 Seminar Series on Grid-Forming (GFM) Technologies

NREL **U.S. DEPARTMENT OF ENERGY**
Transforming ENERGY

Who Organized by the DOE UNIFI Consortium
Where Zoom • Register [HERE](#)
When Mondays at 4-5 ET • 3-4 CT • 2-3 MT • 1-2 PT From Jan 24 to May 2, 2022
Contact Diane Littau • diane.littau@nrel.gov

Jan 24 • Ben Kroposki (NREL) UNIFI Consortium Overview	Mar 21 • Karon Moxiano-Martinez & Sushrut Thakur (ASU) Student Presentation: Detailed Primary and Secondary Distribution System Model Enhancement Using AMI Data
Jan 31 • Wei Du (PNML) Transient and Dynamic Modeling of Droop-Controlled, Grid-Forming Inverters at Scale	Mar 28 • Rodrigo Henriquez-Auba & Jose Daniel Larrañaga Berberich Student Presentation: Resilient Power System Simulation Classification and Assumptions in the Presence of Inertia-based Resources
Feb 7 • Marija Ilic (MIT) Unified energy dynamics based approach to establishing identification methods in support of efficient and reliable large-scale integration of microgrids	April 4 • Federico Milano (UC-Dublin) Complex Frequency: A Geometric Approach to unravel the link between Power & Frequency in AC Power Systems
Feb 14 • Wenzong Wang (EPRI) Specifications and requirements for grid forming inverters in microgrid applications	April 11 • Jin Tan (NREL) Comparative Stability Analysis of Grid-Forming and Grid-Following Inverters in Low-Inertia Power System
Feb 21 • President's Day No Seminar	
Feb 28 • Addison Li (Hawaiian Electric Company) Hawaii's Path to 100% Renewables	April 18 • Ali Mehrizi-Sani (Virginia Tech) Control, Communication, and Cybersecurity for Grid-forming Inverters
Mar 7 • Pedro Arsuaga (General Electric) GE's Perspectives on Grid Forming Technologies	April 25 • Sudipta Chakraborty (OPAL-RT) Axel Seibel and Tobias Erckrath (Fraunhofer IEE) Challenges and needed functionalities of grid forming units for multi-inverter, interoperable, and resilient operation: From HW design, control interoperability and HIL validation
Mar 14 • Xiaonan Lu (Temple University) Large-Scale DER Integration through Scalable & Secure Secondary Control in Dynamic Microgrids	May 2 • Jack Flicker (Sandia) HIL evaluation of GFM Inverters

Register for Spring 2022: https://nrel.zoomgov.com/meeting/register/vJlSf-iuqT8pH3JW9MffrITPmAsfXgzZ_q8

The image features a dense background of light blue icons representing various fields: technology (laptops, routers, servers), energy (solar panels, wind turbines, batteries), industry (factories, cars), and people (groups of figures, a person at a whiteboard). The Unifi Consortium logo is prominently displayed in the top left corner.

unifi
consortium

Moving forward

How to get involved with UNIFI?

- UNIFI has a membership structure over the next few months to allow organization that are not part of the original project to join.



Benefits of Membership

- Access to Working Groups
- Participate in the development of GFM interoperability specifications
- Access to experts in GFM
- Access to educational and workforce development material

For more information on Memberships Contact: Ben Kroposki (benjamin.kroposki@nrel.gov) or Iqbal Hussain (ihusain2@ncsu.edu)

Membership Levels & Benefits

Benefits	Full Member (\$50,000/yr)	Startup Member ^[a] (\$5,000/yr)	Non-profit Member (\$3,000/yr)	Associate Member (\$10,000/yr)	Affiliate Member (\$3,000) ^[b]
Voting member (points)	50	5	3	10	0
Early access to UNIFI Specifications	✓	✓	✓	✓	✓
Access to UNIFI core-stack IP (note: access may not be free)	✓	✓	✓	✓	✓
Participation in UNIFI events (workshops, trainings, job fairs, etc.)	✓	✓	✓	<i>limited</i>	<i>limited</i>
Development of UNIFI Specifications (based on votes)	✓	✓	✓	✓	
Participation in UNIFI working groups	✓	✓	✓	<i>limited</i>	
Access to education and workforce-development material	✓	✓	✓	<i>limited</i>	
Access to demonstrations	✓	✓	✓		
Access to member-provided or other new funding	✓	✓	<i>limited</i>		
Decide on member-funded projects (based on votes)	✓	✓			

- Structure in place for Years 1-5 of Consortium; subject to adjustment per bylaws
- *limited* defined per the bylaws
- [a] Startup members must have less than 50 employees and be less than 5 years old
- [b] One & only fee for 5 years

Why should you join?

- Seat at the table alongside other vendors, utilities, system operators
- Participate in (and drive) cutting-edge R&D through UNIFI working groups
- UNIFI specifications (interoperability guidelines + functional requirements) will leapfrog traditional standardization
- Access to core stack IP that is key to interoperability of GFM technologies across scales
- Participate in 1MW and 20MW demos
- Network with wide student pool across universities that will enter workforce
- UNIFI events (training, job fairs, workshops) will be key to educate on novel technology area
- Access to educational and training material in up-and-coming technology space



Where can I find out more information?

- UNIFI Website is underdevelopment
- UNIFI website will provide more information and access to specifications and material for members as well as public information
- We will also send out info on LinkedIn
 - Check for the the “**UNIFI Consortium**” Group



For more information

■ Benjamin Kroposki

- UNIFI Organizational Director
- Director, Power Systems Engineering Center, NREL
- benjamin.kroposki@nrel.gov

■ Iqbal Husain

- UNIFI Sustainability Officer
- Professor, NCSU
- iqbal_husain@ncsu.edu

■ UNIFI LinkedIn group



The image features a dense background of light blue icons representing various fields: technology (laptops, tablets, Wi-Fi symbols), energy (solar panels, wind turbines, batteries), science (graphs, charts, molecular structures), and industry (factories, rockets, construction workers). The 'unifi consortium' logo is prominently displayed in the top left corner in a bold, dark blue font.

unifi
consortium

Thank you