



# Tracing the Oscillations – A Few Pieces of the Puzzle

**Yunjie Gu<sup>1</sup>, Slava Maslennikov<sup>2</sup>, Shahil Shah<sup>3</sup>**

1. Imperial College London, 2. ISO-NE, 3. NREL

# Mysterious Oscillations

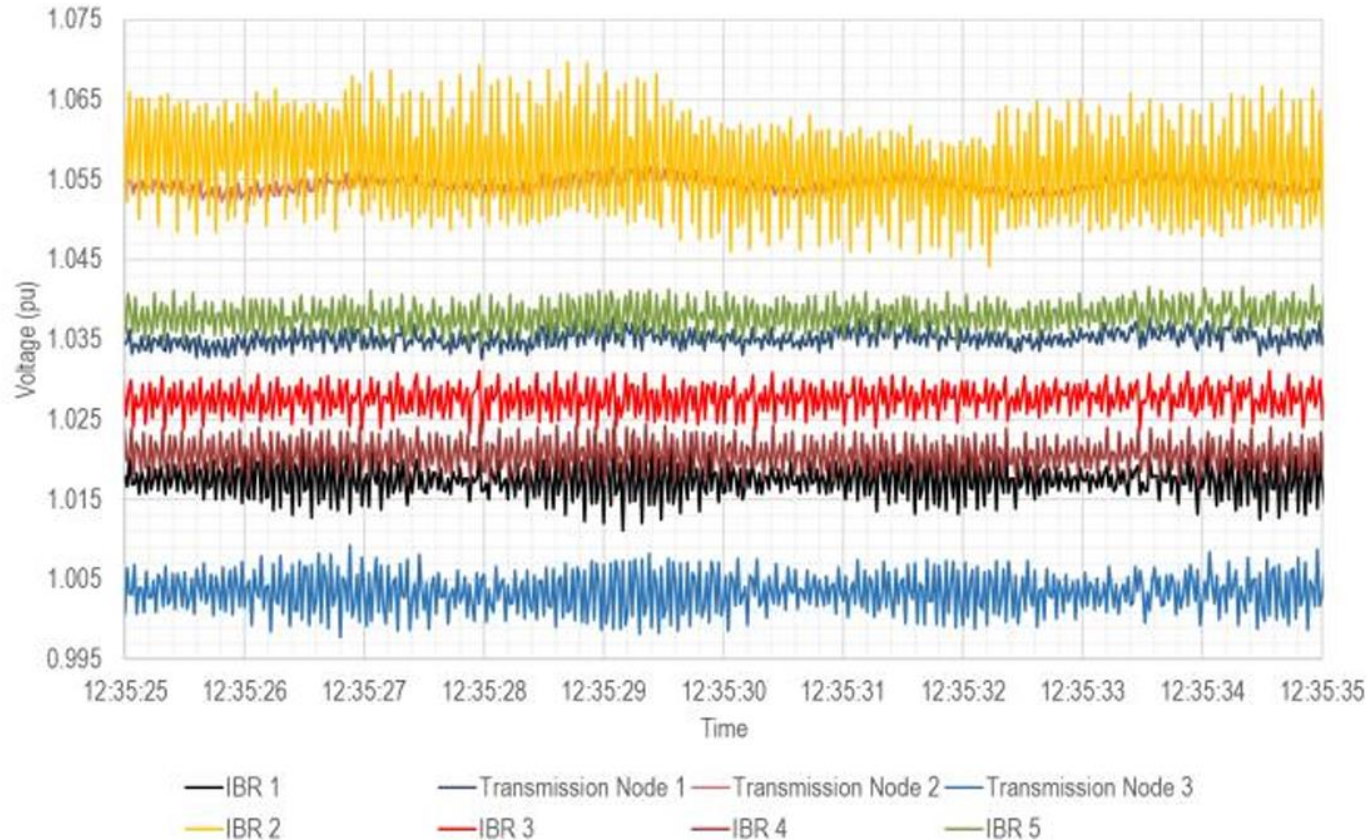

Sub-synchronous Oscillations in West Murray Zone (WMZ), Australia, since 2019. Source: [High level summary of WMZ – Subsynchronous Oscillations](#).

- The sub-synchronous oscillations seem to be intermittent and occurring both with and without any apparent disturbance in the WMZ or surrounding region.
- The frequency of oscillations is mostly around 17-19 Hz (RMS).
- The oscillations have been identified as contained in the north-west of Victoria and specifically around the Red Cliffs and Wemen area, likely involving the following solar plants: Wemen, Bannerton, Karadoc, Yatpool & Kiamal.
- Based on instances when the response of these solar plants was analysed, the Q and V response from the solar plants were sometimes in-phase and sometimes out-of-phase.
- The system operator replicated the oscillation in their EMT simulation models, after two years.
- Impedance analysis has found the source of oscillations to be an underdamped mode in few IBRs and creation of system mode by few IBRs.

# Mysterious Oscillations

## Voltage Oscillation in Scotland in 2021

- On 24/08/2021 severe voltage disturbances were observed on the SSEN-T and SPEN transmission systems.
- Major disturbance lasted 20-25 seconds on two occasions, approx. 30 minutes apart
- Investigation of available data suggests:
  - The oscillations with the largest magnitude were in the north of Scotland
  - The oscillations had a frequency of  $\approx 8$  Hz
- Some Users tripped off during the disturbances

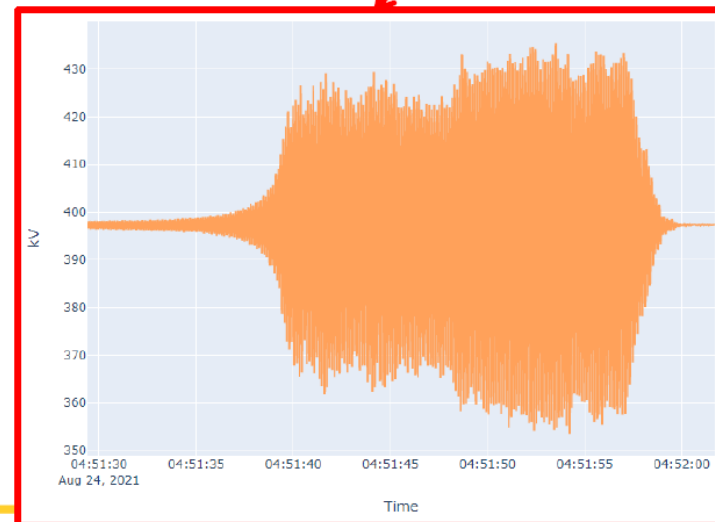
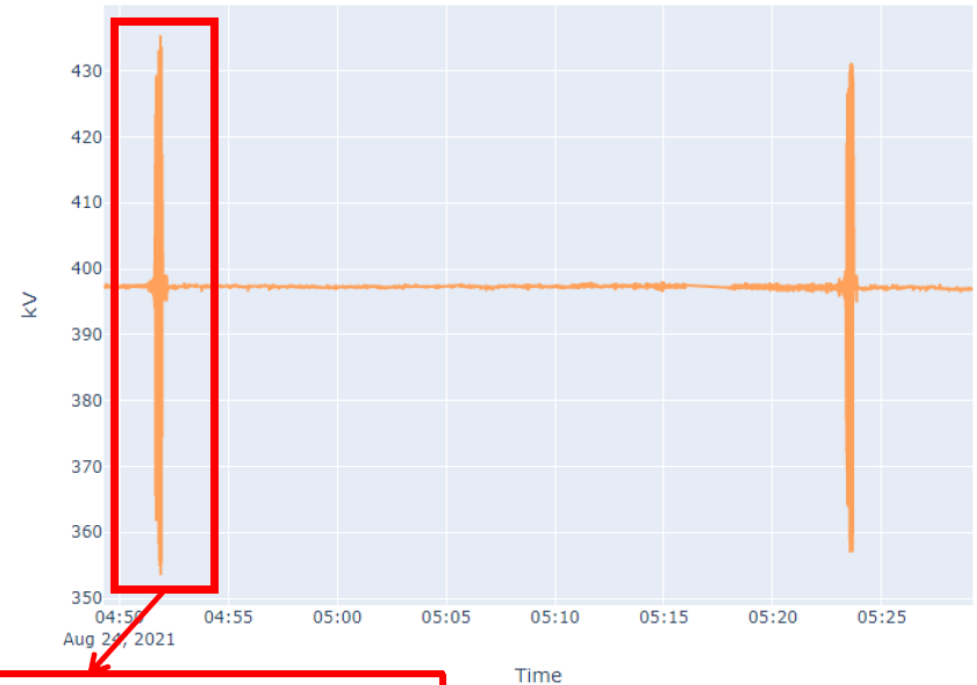

# Forced Oscillation or Free (Natural) Oscillation?

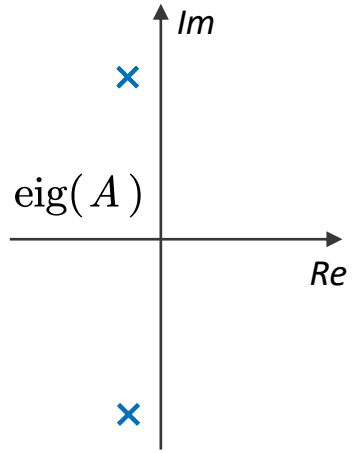

$$\dot{x} = Ax + u$$

## Forced Oscillations:

- System is **stable** (eigen value of  $A$  has negative real part)
- Oscillation is driven by periodic external input  $u$ , caused by failed components or load fluctuations
- Common in synchronous-generator-based power systems, where mechanical components fail (steam valve, turbine blades...)
- The origin of forced oscillations are the external input, and the mitigation scheme is to remove the external input (by repairing a failed component)

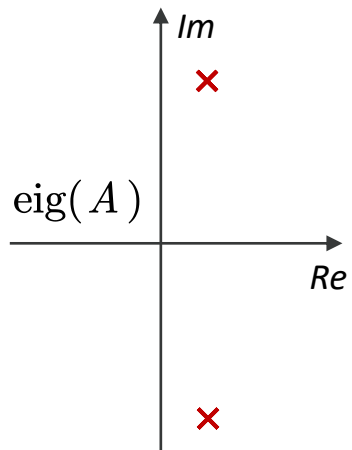

$$\dot{x} = Ax$$

## Free Oscillations:

- System is **unstable** (eigen value of  $A$  has positive real part)
- Oscillation is driven by interactions among states without external inputs
- Common in inverter-based-systems (electronics do not easily fail but may create control interactions)
- The origin of free oscillations are self-amplifying interactions between states, and the mitigation scheme is to damp the interactions (by tuning control)

# Forced Oscillation or Free (Natural) Oscillation?

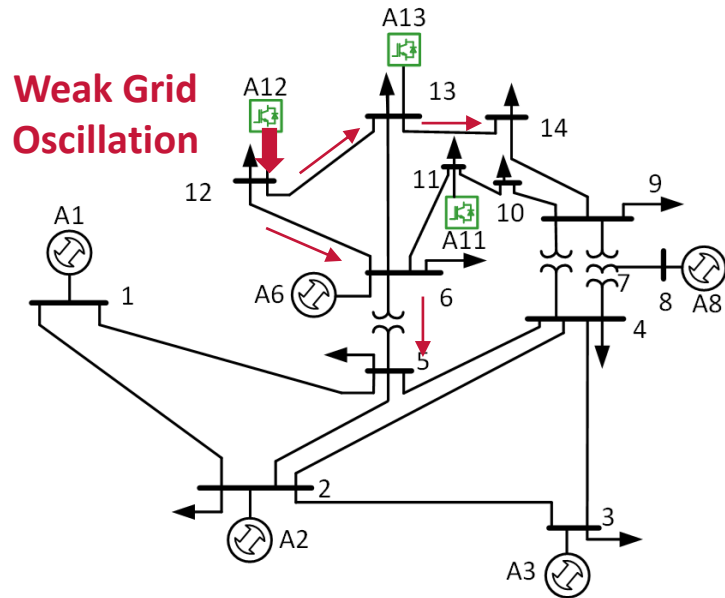

## Some Free Oscillations are Misunderstood as Forced:

- A typical case is IBR-weak grid oscillations, which is induced by a single IBR but is propagated to other nodes in the grid.
- From the whole-system point of view, it is free oscillation; only for the system excluding the unstable IBR, it is forced oscillation.

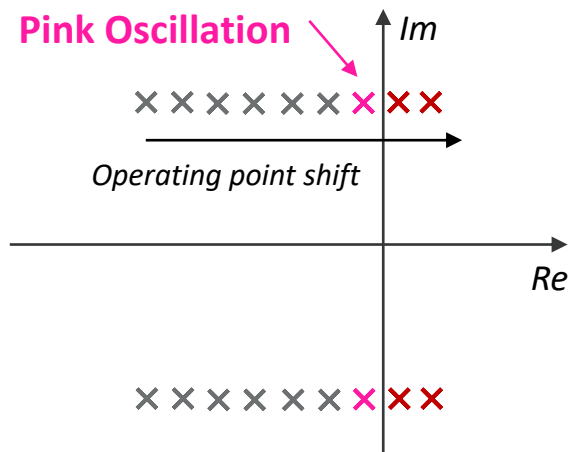

## Mid-Ground Between Forced and Free: Pink Oscillations

- As the operating point shifts, the eigenvalue moves towards unstable.
- Before becoming complete unstable, the eigenvalue becomes very underdamped, which induces pink oscillation, that is, oscillation excited by ambient noise (like load fluctuations).
- Pink oscillation is forced oscillation but should be mitigated as free oscillation, because it is impossible to remove ambient noise.

# What is Required for a Tracing Method?

## Morality

- To set up a *moral standard* for *good* and *bad* behaviours in terms of system stability
- To index and rank the moral merit (good or bad) of different components

## Effectiveness

- To identify the effective component to mitigate or excite a particular oscillation
- To index and rank the effectiveness of components in oscillation mitigation

## **Are Morality and Effectiveness always aligned?**

Is “taming the bad guys” always the most effective solution to mitigate oscillation?

# Oscillation Tracing Methods

**Data-Driven  
(Model Free)**

*Energy-Based  
Method*

*Phase Compass Plot*

**Real-Time Operation,  
Post-Event Analysis**

**Data-Led  
(Data + Blackbox Model)**

*Impedance  
Sensitivity*

**Model-Driven  
(White-Box State-Space Model)**

*State Sensitivity*

**Planning, Pre-Event Screening**

# Energy Based Method

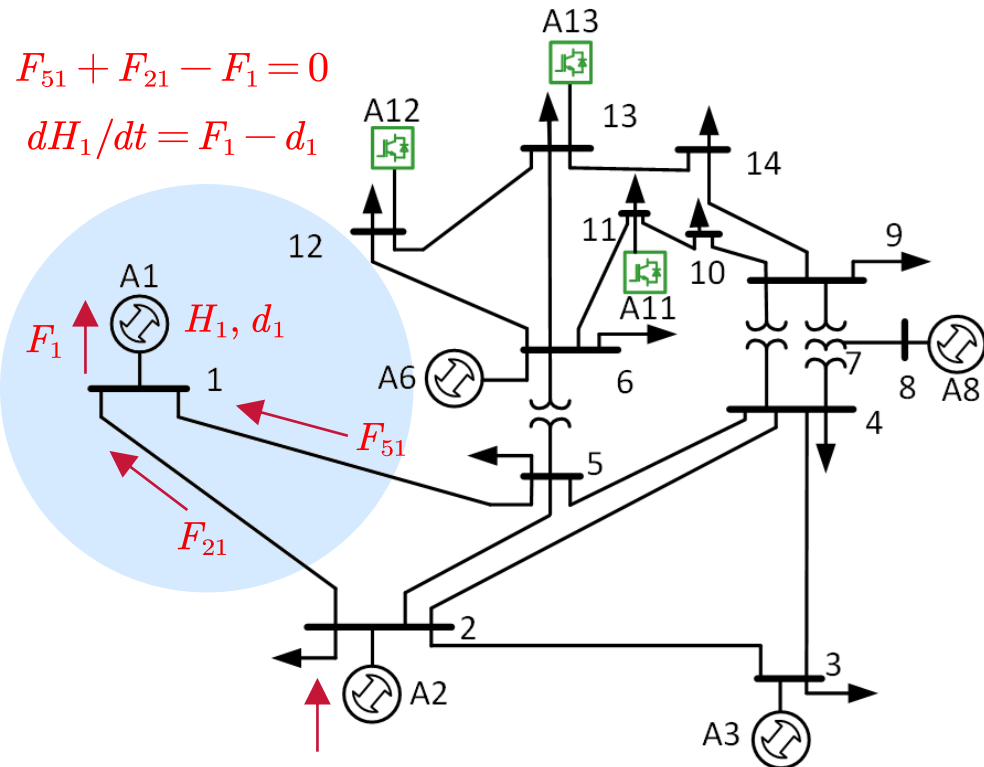

## Two principles for a meaningful energy flow

- **Conservation:** the net energy flows into every bus in the network must be zero.

$$\sum F_{bus} = 0$$

- **Consistency:** the flows are associated with energy functions  $H$  that are consistent across all plants.

$$dH_k/dt = F_k - d_k$$

where  $H$  is energy storage,  $F$  is flow, and  $d$  is dissipation

- **Dissipation** of energy ( $d$ ) governs the stability of the system, which is observable from energy flow ( $F$ ).
- **Morality** is achieved by distinguishing the source (bad) and sink (good) of energy flow. Effectiveness?

# Different Definitions of Energy Flow

## Dissipation Energy Flow (DEF, original form) [1,2]

Definition	$F = \Delta P \Delta\omega + \Delta Q \Delta\dot{V}/V$
Interpretation	Mechanical dissipation
Equivalence	Damping torque coefficient
Applicability	Angle and torsional oscillation

## Oscillation Power Flow [3]

Definition	$F = \Delta V_d \Delta I_d + \Delta V_q \Delta I_q$
Interpretation	Electrical dissipation
Equivalence	Resistance
Applicability	Electromagnetic oscillation

[1] Maslennikov, S., Wang, B. and Litvinov, E., 2017. Dissipating energy flow method for locating the source of sustained oscillations. *International Journal of Electrical Power & Energy Systems*, 88, pp.55-62.

[2] Chen, L., Min, Y. and Hu, W., 2012. An energy-based method for location of power system oscillation source. *IEEE Transactions on Power Systems*, 28(2), pp.828-836.

[3] Xie, X., Zhan, Y., Shair, J., Ka, Z. and Chang, X., 2019. Identifying the source of subsynchronous control interaction via wide-area monitoring of sub/super-synchronous power flows. *IEEE Transactions on Power Delivery*, 35(5), pp.2177-2185.

# Dissipation vs. Passivity vs. Damping

- In control theory, dissipation = passivity
- In power engineering, passivity refers to electrical dissipation (positive resistance)
- Dissipation contributes to damping only if they are consistent
  - Mechanical dissipation contributes to the damping of angle swing and torsional resonance
  - Electrical dissipation contributes to the damping of electromagnetic resonance

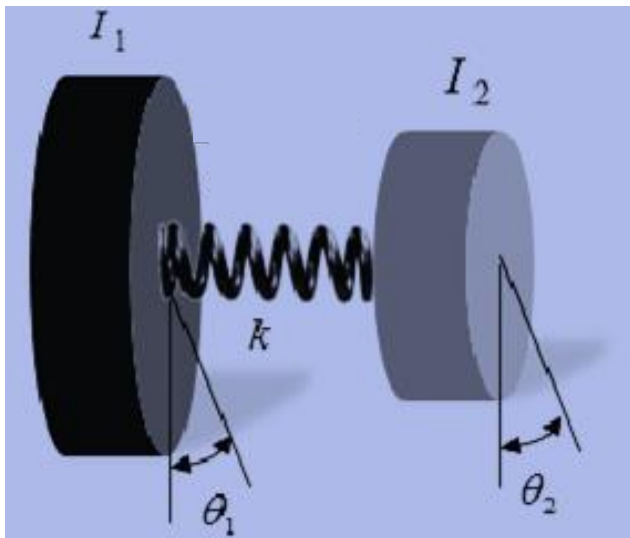

*Torsional resonance: damped by mechanical dissipation (positive torque coefficient)*

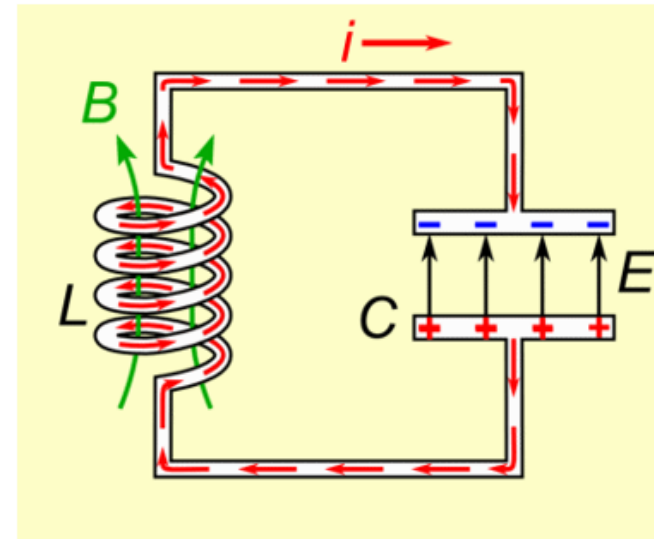

*Electromagnetic resonance: damped by electrical dissipation (positive resistance)*

# DEF vs. Phase Compass Plot

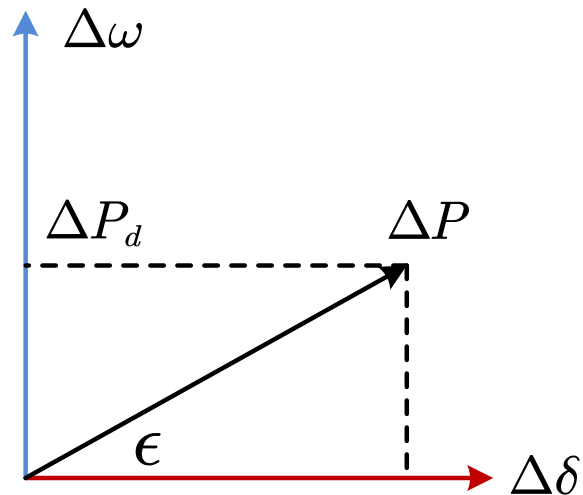

$$\Delta\omega = |\Delta\omega|\cos(\omega_0 t + \pi/2)$$

$$\Delta\delta = |\Delta\delta|\cos(\omega_0 t)$$

$$\Delta P = |\Delta P|\cos(\omega_0 t + \epsilon)$$

$$F = \Delta\omega \Delta P = |\Delta\omega| |\Delta P| \cos(\omega_0 t + \pi/2) \cos(\omega_0 t + \epsilon)$$

$$= \frac{1}{2} |\Delta\omega| |\Delta P_d| - \frac{1}{2} |\Delta\omega| |\Delta P| \sin(2\omega_0 t + \epsilon)$$

$P_d$  is proportional to the dc component of DEF.

**The phase compass plot method is DEF method transformed to the frequency domain.**

# Phase Compass Plot vs. Mode Shape

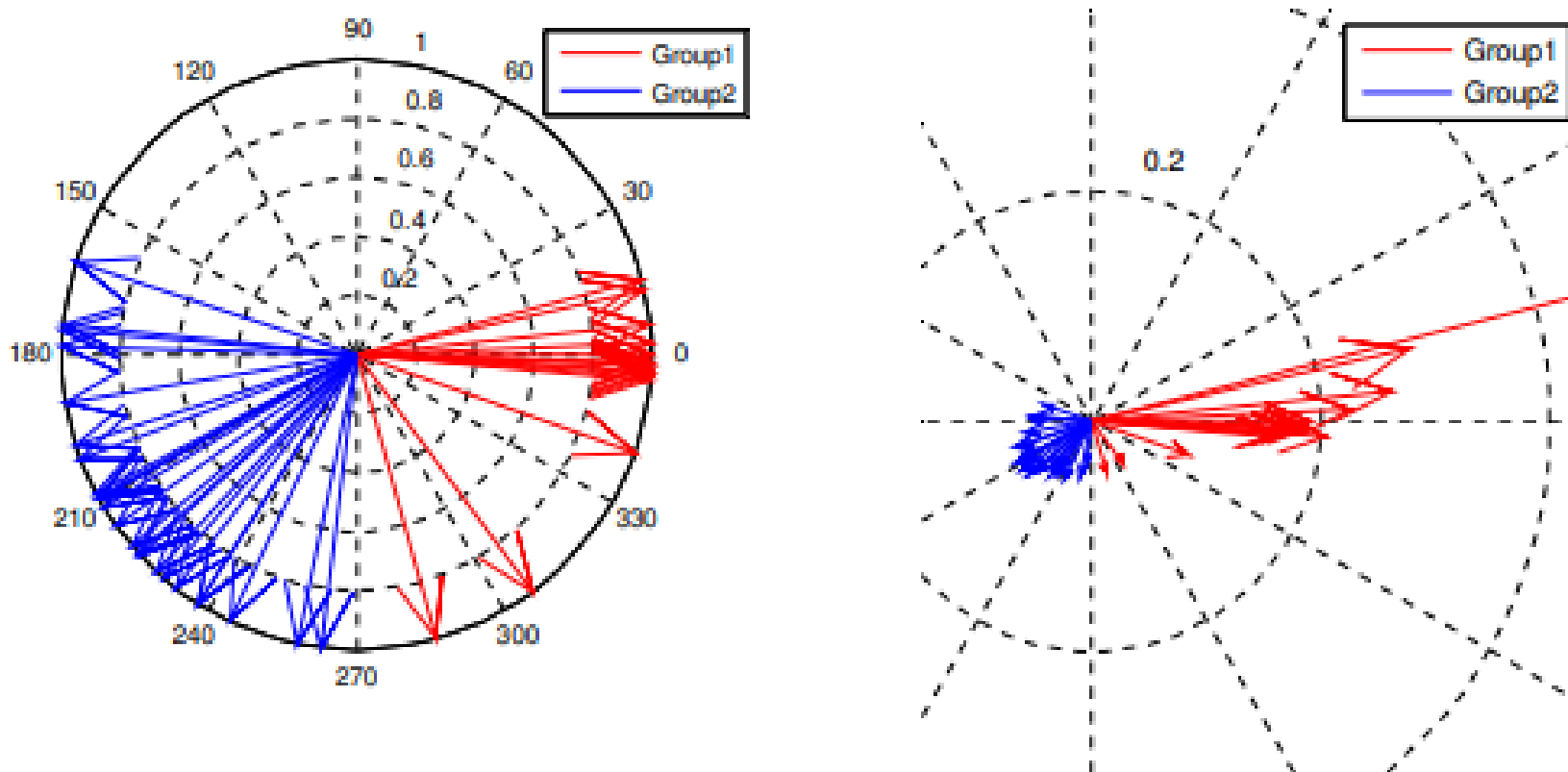

*Phase compass plot can display the phase distribution of multiple buses to identify the pathway of interaction for an inter-area mode. It is essentially the **mode shape** of the measured states.*

# Sensitivity Analysis: A Generic Way for Oscillation Tracing

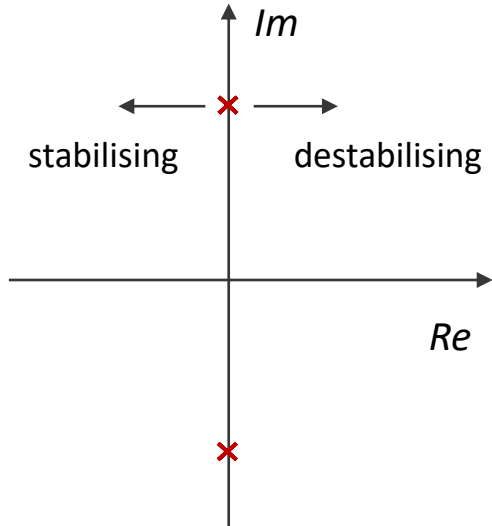

$$p_{ik} = \phi_{ik} \psi_{ki} = \frac{\partial \lambda_k}{\partial A_{ii}}$$

Participation factor: sensitivity of oscillation modes to states

- The different definitions of energy flow all have their successful cases, but none universal.
- The applicability of energy flow is up to its consistency with damping.
- Sensitivity analysis directly investigates damping itself (the real part of the eigenvalue) and is therefore generic.
- Sensitivity analysis does not distinguish sources (bad) and sinks (good): **effective** but not necessarily **moral**.
- More importantly, sensitivity analysis requires a state-space model, which is not available.

- In energy flow, the left side is source and the right side is sink of oscillation.
- In sensitivity analysis, left and right has equal participation: sensitivity analysis is effective but not moral.

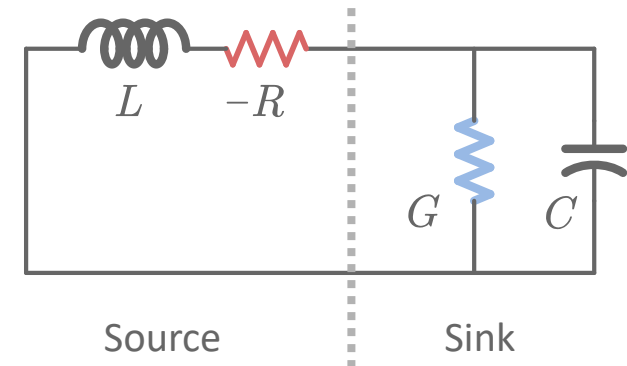

# Port-Based Sensitivity: Impedance Participation Factor

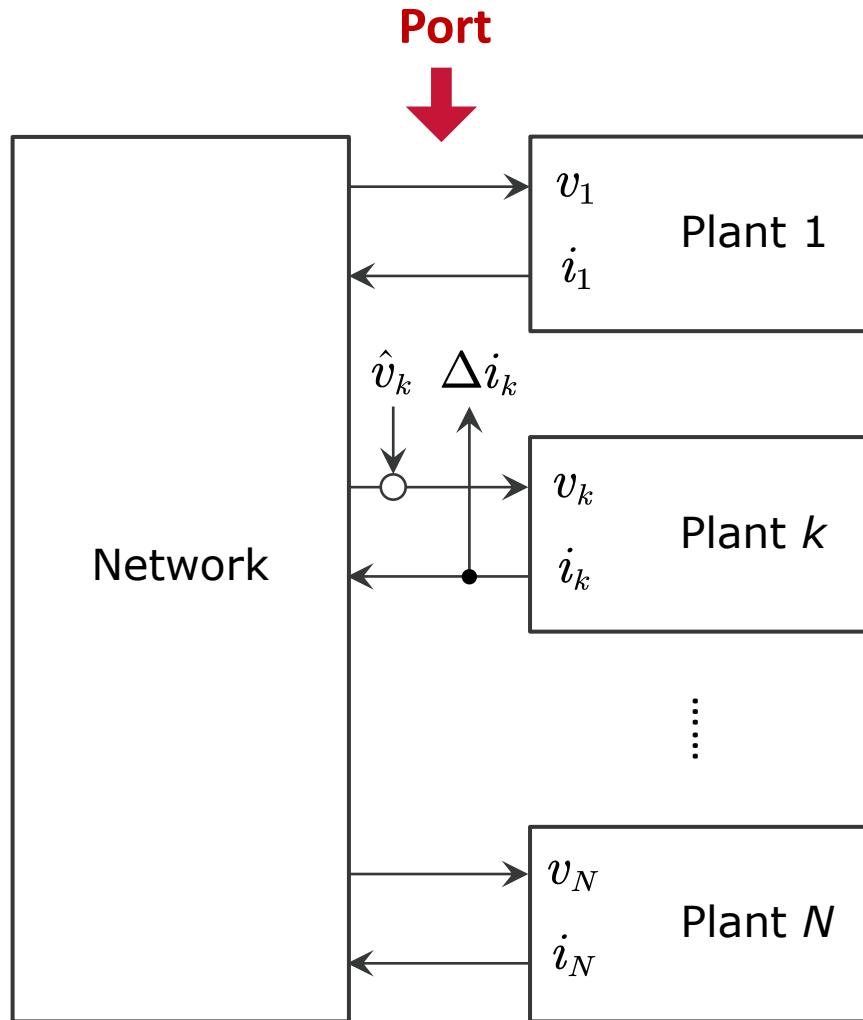

$$\hat{Y}_{kk}(s) = \frac{R_1}{s - \lambda_1} + \frac{R_2}{s - \lambda_2} + \dots + \frac{R_N}{s - \lambda_N}$$

← Residue  
← Eigenvalue

**The residue Lemma:** residue of admittance  $\hat{Y}_{kk}$  at node  $k$  equals the sensitivity of eigenvalue to the plant impedance connected at that node.

$$-\text{Res}(\hat{Y}_{kk}(s), \lambda) = \frac{\partial \lambda}{\partial Z_k(\lambda)}$$

The residue Lemma yields the **impedance participation factor**

$$p_{\lambda, Z_k} \triangleq -\text{Res}(\hat{Y}_{kk}(s), \lambda)^*$$

# Impedance-Based Oscillation Tracing

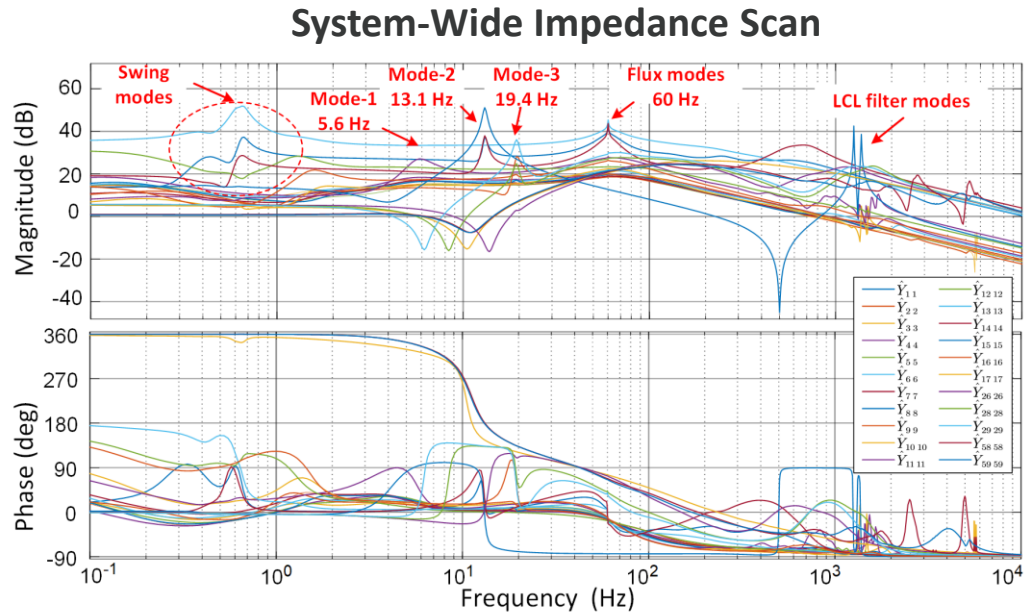

Identifying mode and impedance sensitivity from data

Zhu, Y., Gu, Y., Green, T.C., 2021. Participation analysis in impedance models: The grey-box approach for power system stability. *IEEE Transactions on Power Systems*.



## 1: Effectiveness

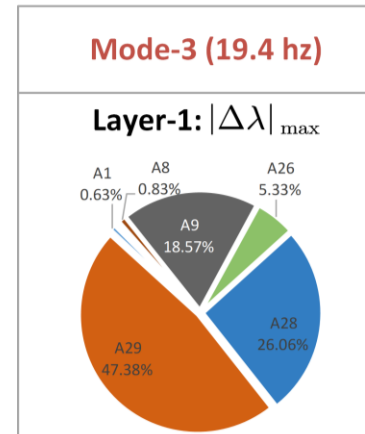
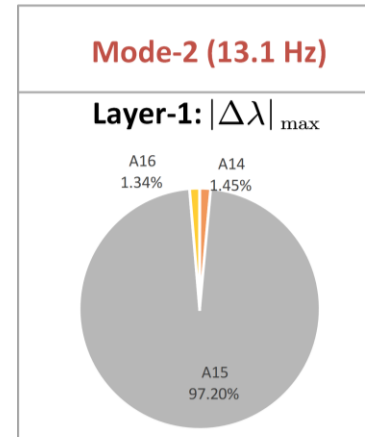

## 2: Morality

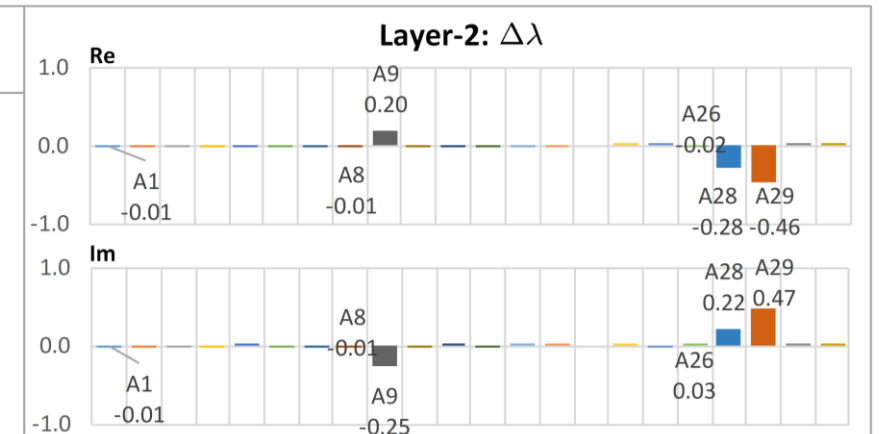
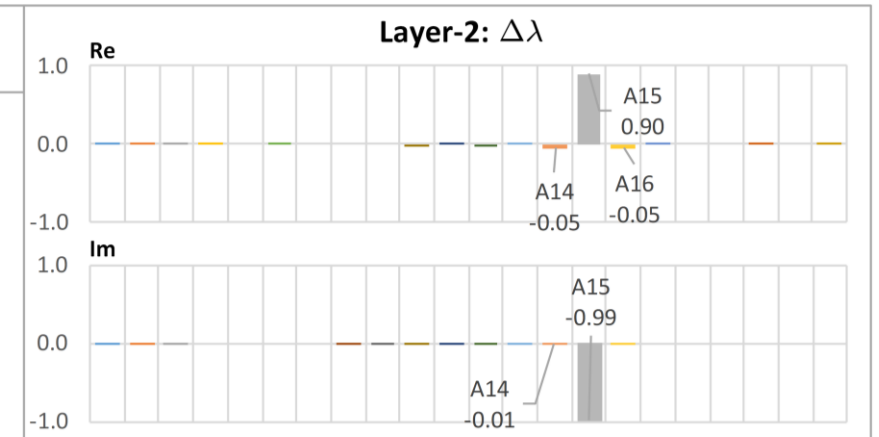

Ranking of effectiveness (Layer 1) and morality (Layer 2) in oscillation damping from impedance sensitivity analysis

# Accelerated System-Wide Impedance Scan

**Step 1:** Identify IBRs and their operation conditions that are suspected to have significant role in the observed oscillations.

**Step 2, SMIB IBR Scan:** Perform impedance scans at IBRs in SMIB (single machine infinite bus) format

- Identify internal resonance modes of IBRs and evaluate their ability to operate stably with grids of different strength conditions (SCR, X/R)

**Step 3, Wide Area Network Scan:** Perform impedance scans of the grid at the terminal of an IBR using wide-area network EMT model

- Identify oscillation modes in the grid and contribution of the IBR to its damping
- Repeat this step as needed at other IBRs

# Reversed Impedance-Based Stability Criterion

Usual Approach

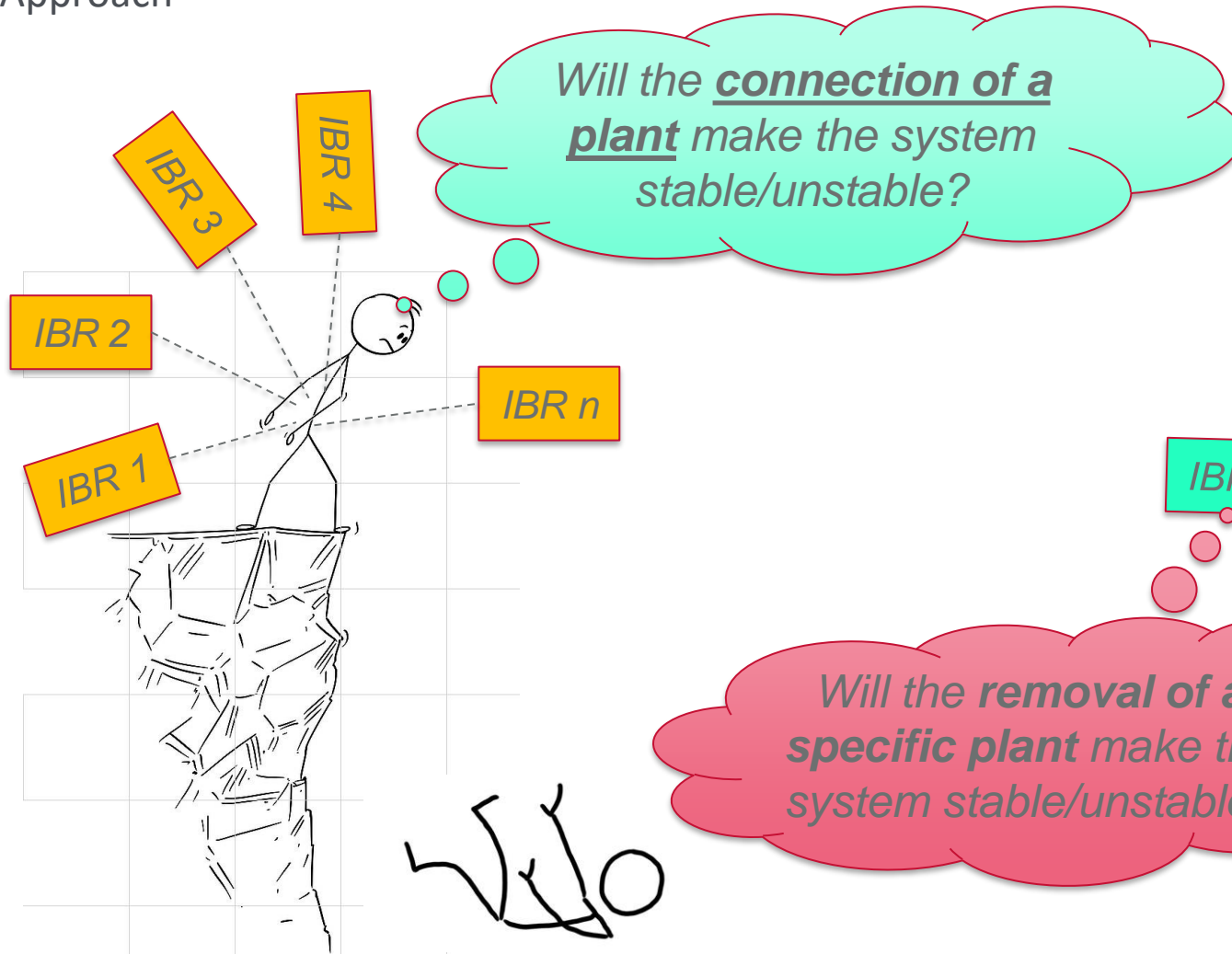

*Reversed Approach*

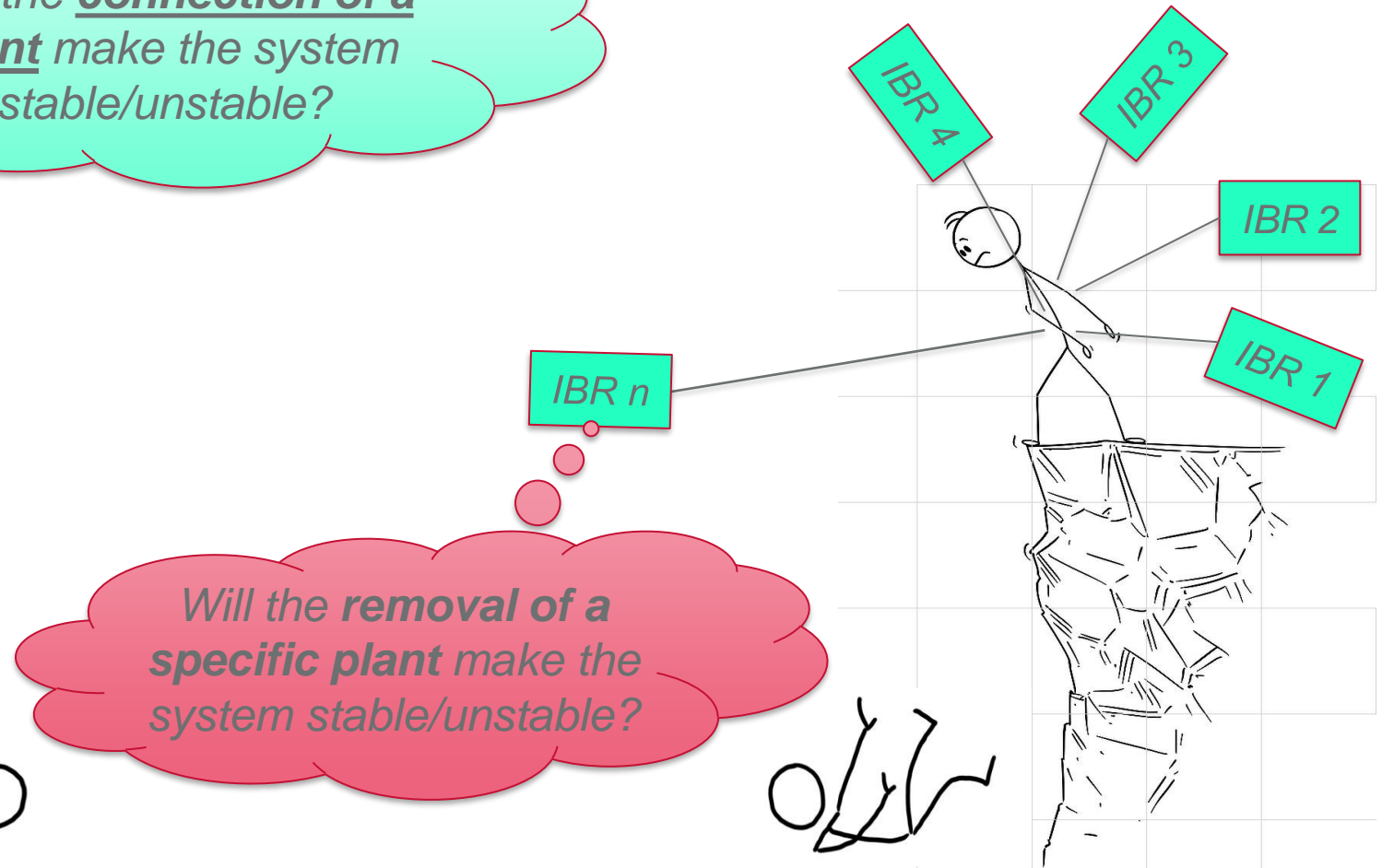

# Case Study: a Weak System with 1.5 Hz Oscillation

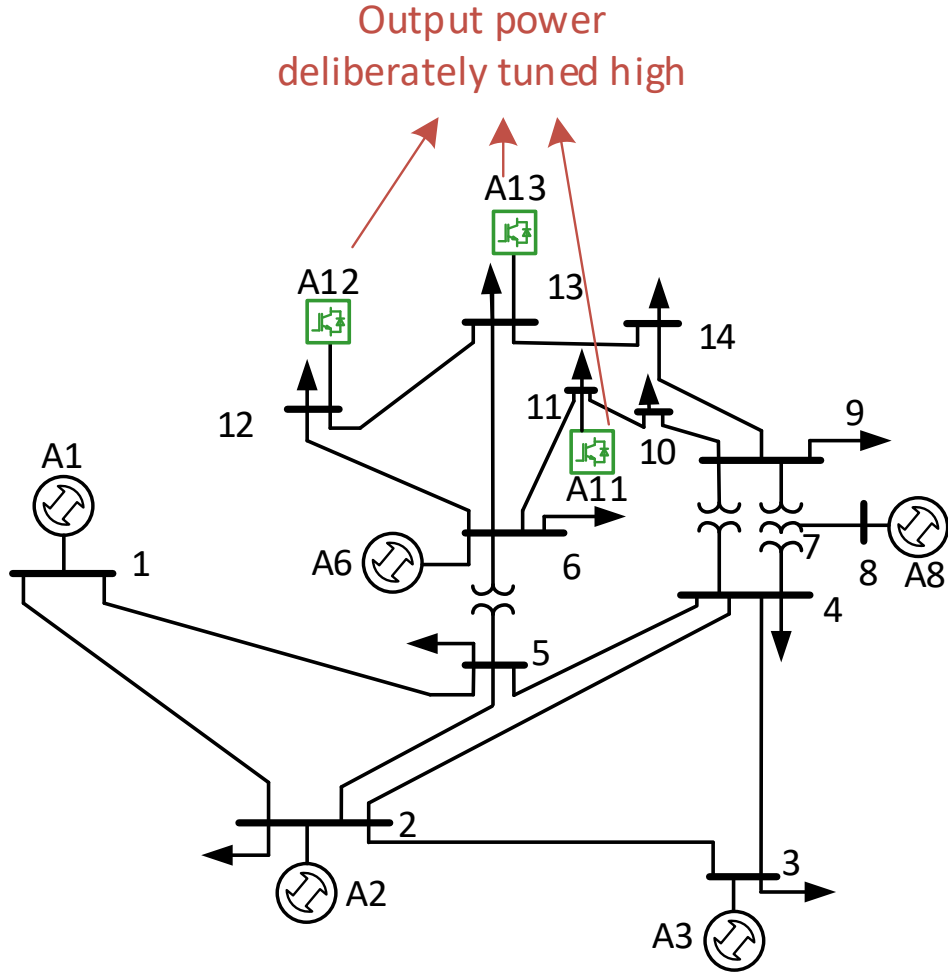

1.5 Hz free oscillation

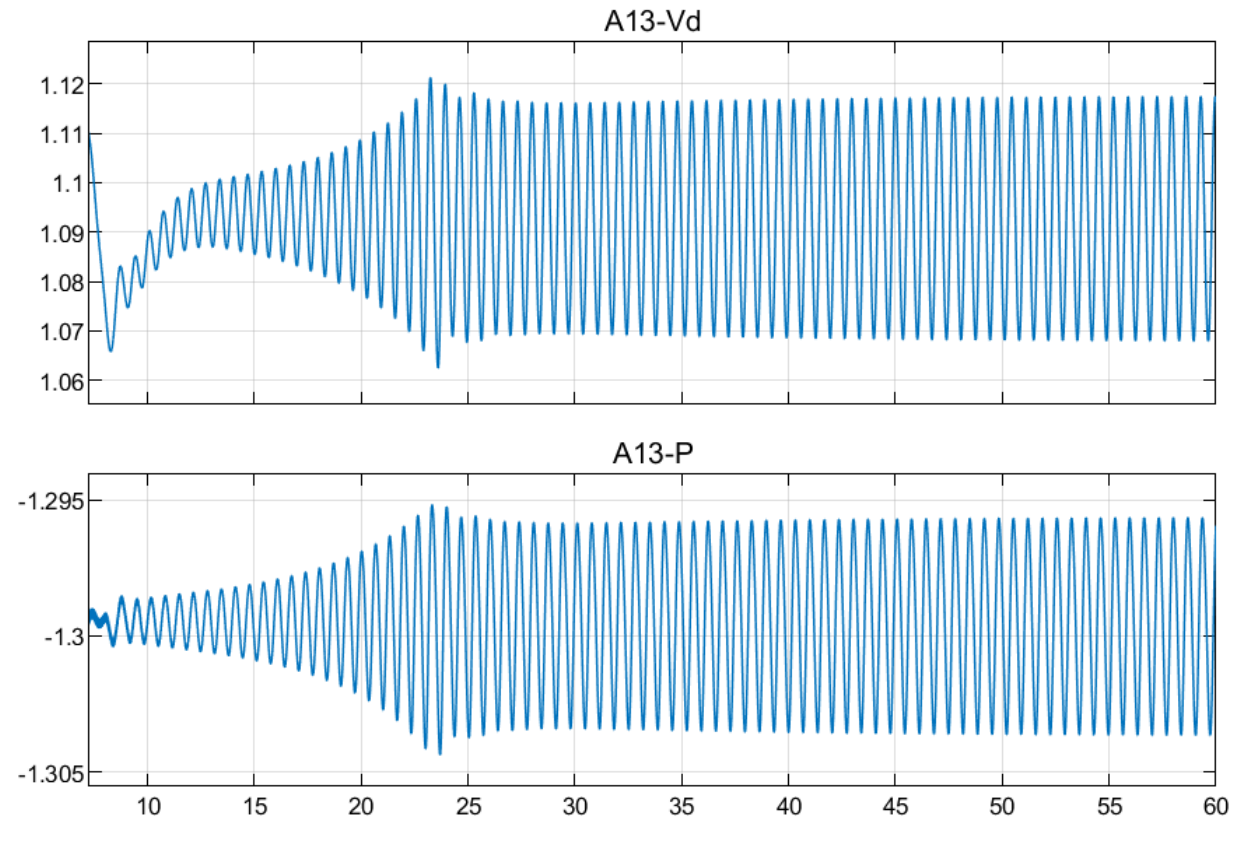

# Impedance-Based Tracing

Impedance Participation Factor: Layer 1

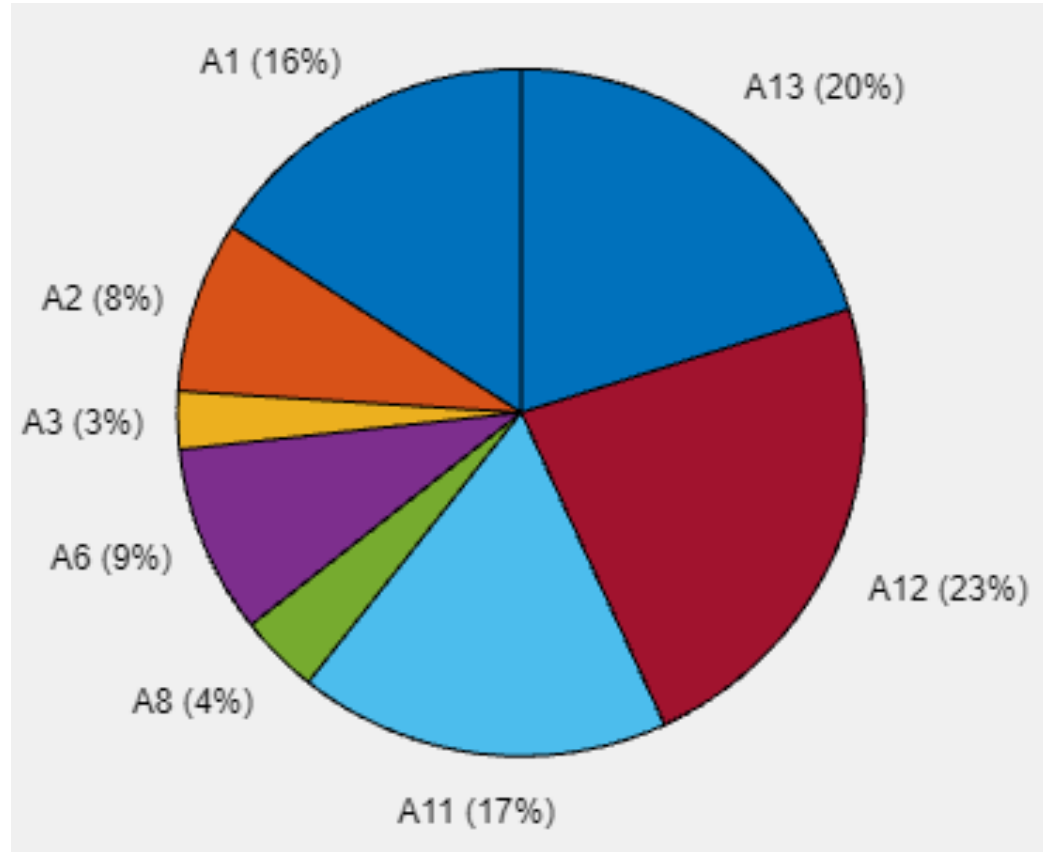

Impedance Participation Factor: Layer 2

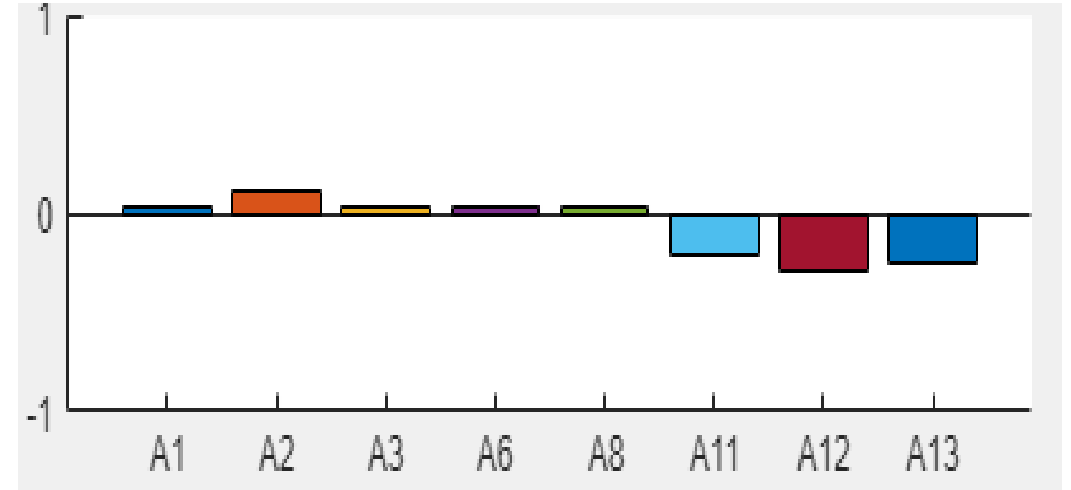

From the impedance-sensitivity analysis, we see

- IBRs (A11, A12, A13) excite the oscillation
- Generators (A1,A2,A3,A6,A8) damp the oscillation

# Energy-Based Tracing

DEF (conventional)

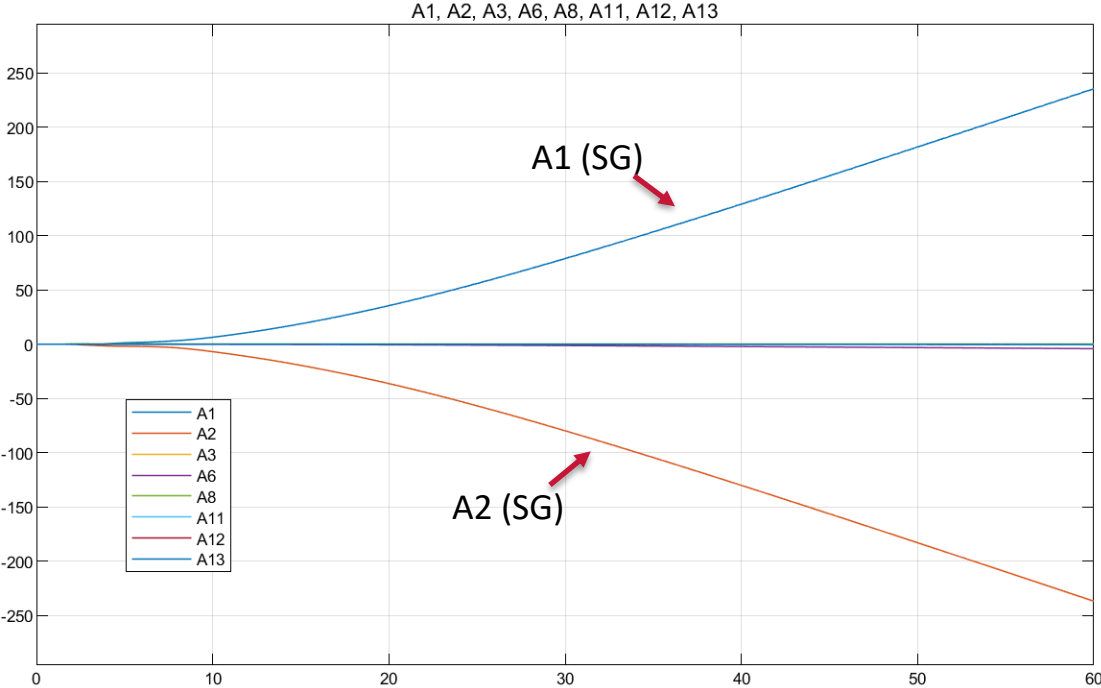

False indication

DEF (modified)

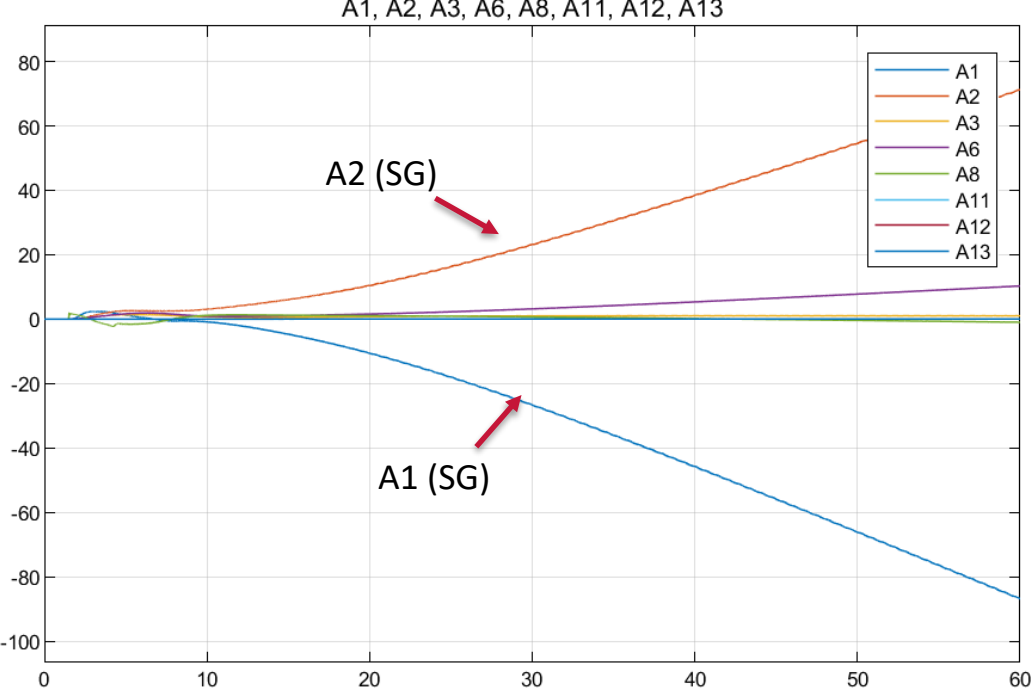

False indication

# Relationships of Oscillation Tracing Methods

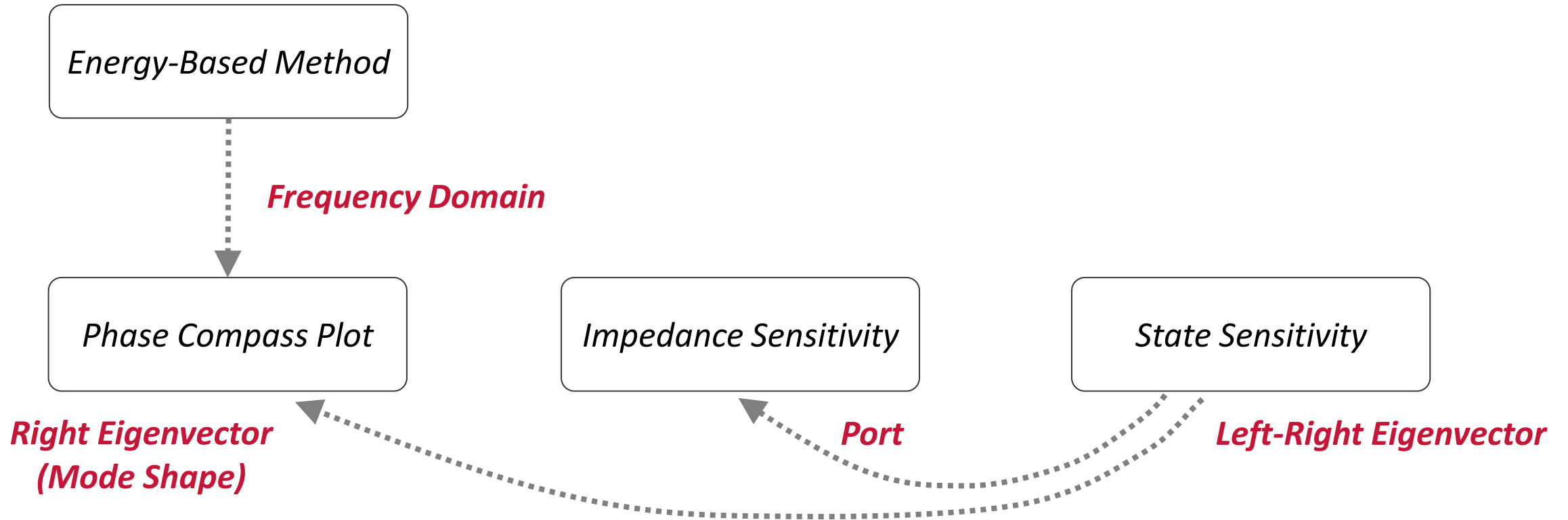

# Relationships of Oscillation Tracing Methods

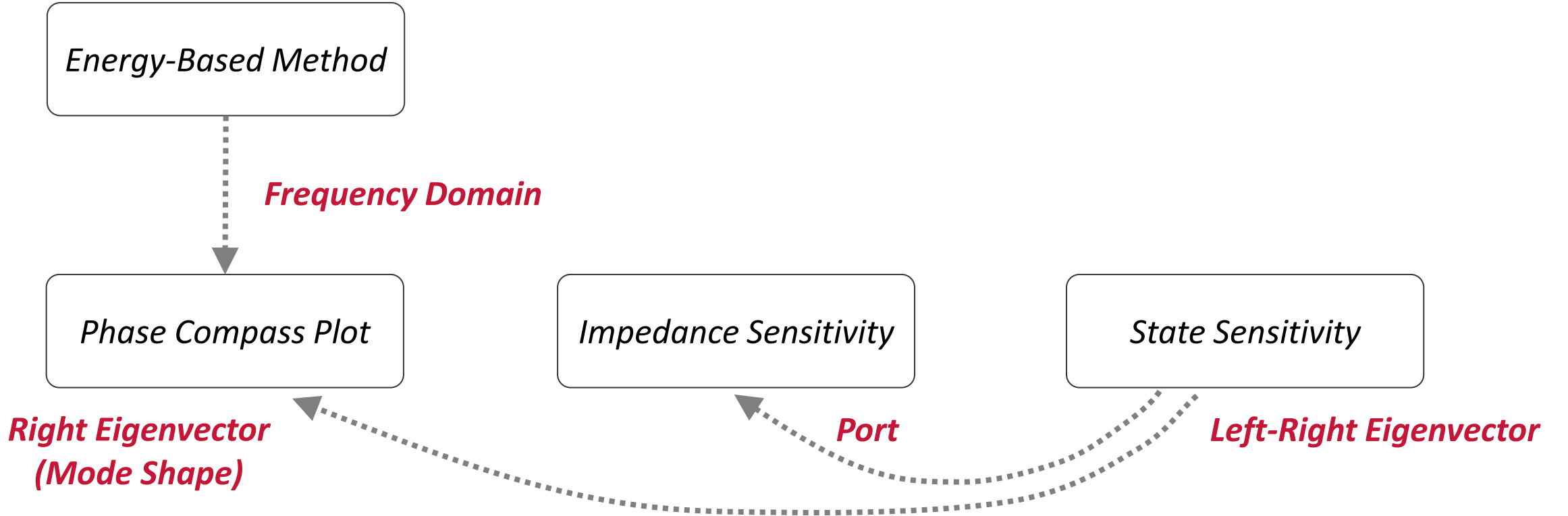

<b>Moral but not always Effective</b>	<b>Effective or Moral</b>	<b>Effective but not always Moral</b>
---	---------------------------	---

**Merit**

# Relationships of Oscillation Tracing Methods

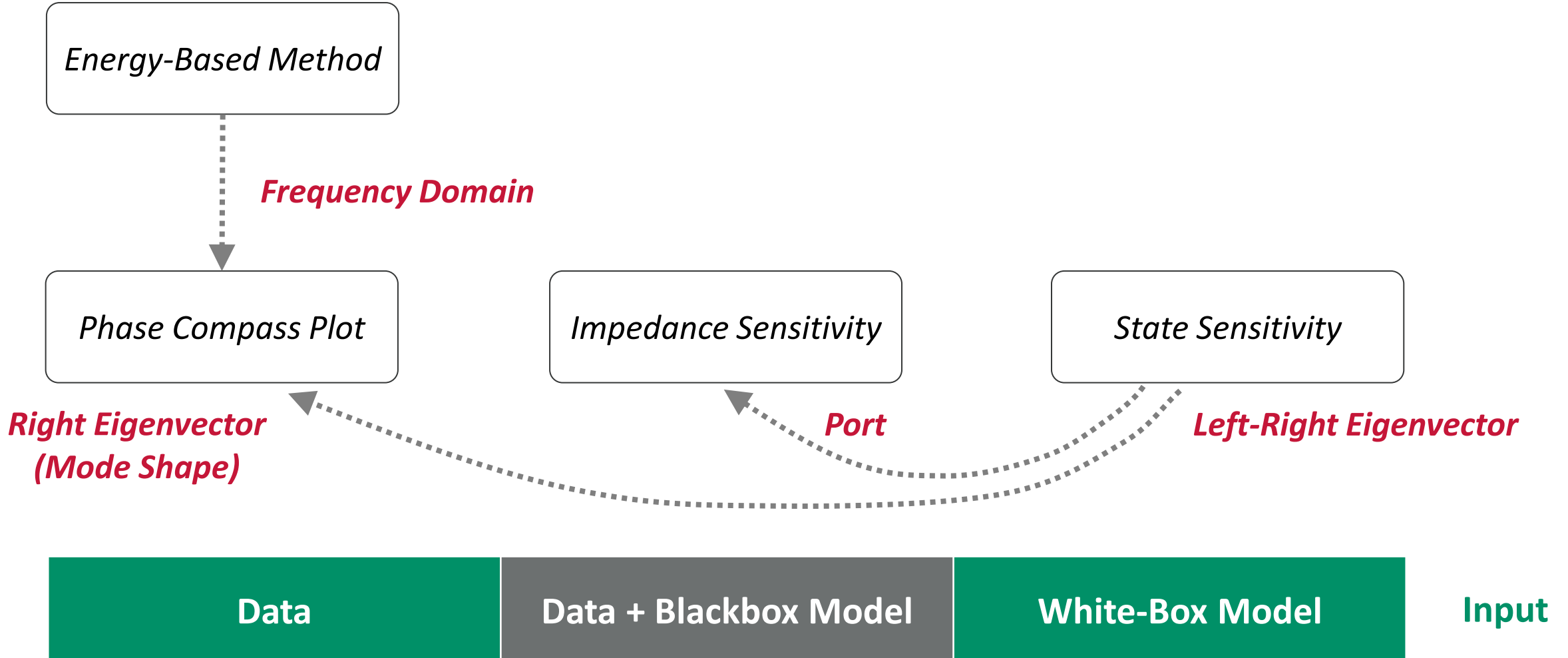

# Relationships of Oscillation Tracing Methods

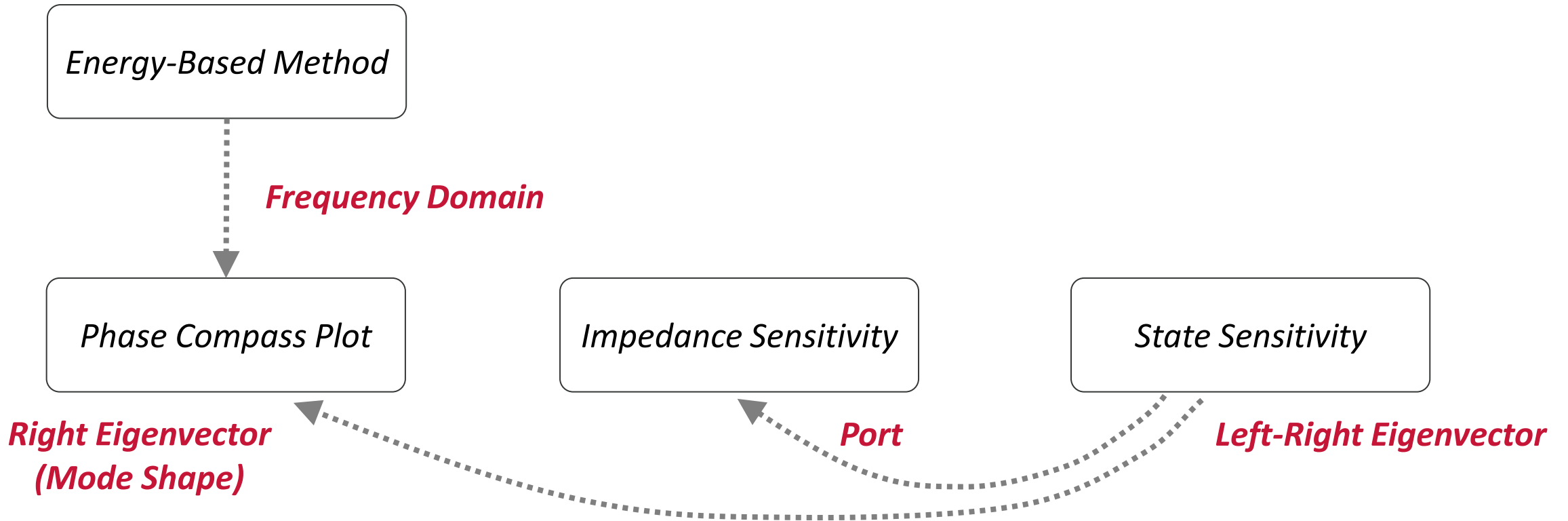

**Real-Time and Post-Event**

**Pre-Event and Offline, with possible extension to Online and Real-Time**

**User**

## Data Quality: Sampling Rate

- The sampling rate of the data must be at least twice the oscillation frequency. Is this enough?
- From the test on commercial PMU with 50Hz sampling rate, significant phase delay is observed from 10Hz.
- For DEF-like method, the phase delay is not a problem if the delay for different signals (e.g. power and frequency) are uniform.
- For phase compass plot method, the pathway of interaction analysis may be compromised by non-uniform phase delay of the PMUs from different vendors.
- Dynamic System Monitoring (DSM) offer much higher sampling rates (several kHz) than PMUs, but DSM data is not synchronised. Is synchronisation necessary?

# Data Quality: Synchronisation

- Only phase compass plot method, used for interaction pathway study, need globally synchronised data (GPS).
- The globally synchronisation also implies that the phase delays of PMUs at different buses are **uniform** up to the oscillation frequency.
- DEF-like methods need locally synchronised data (e.g. power and frequency on the same bus).
- Impedance participation factor is currently used for offline study based on EMT models. If it is taken online (digital-twin), it might or might not need synchronised data (depending on how the system is probed).
- PMU on distribution network is synchronised but may also suffer from phase differences due to load flow.
- Clear specification of measurement devices is needed to make the data useful.

# *Success Stories*

# 2021 IEEE/NASPI Oscillation Source Location Contest\*

- Objective: help to identify tools for practical use
- Test system : NREL's 240-bus WECC model
- 13 realistic test cases of **traditional oscillations**
- Participation: 60 sign-ups, 21 submissions
- OSL methods utilized:

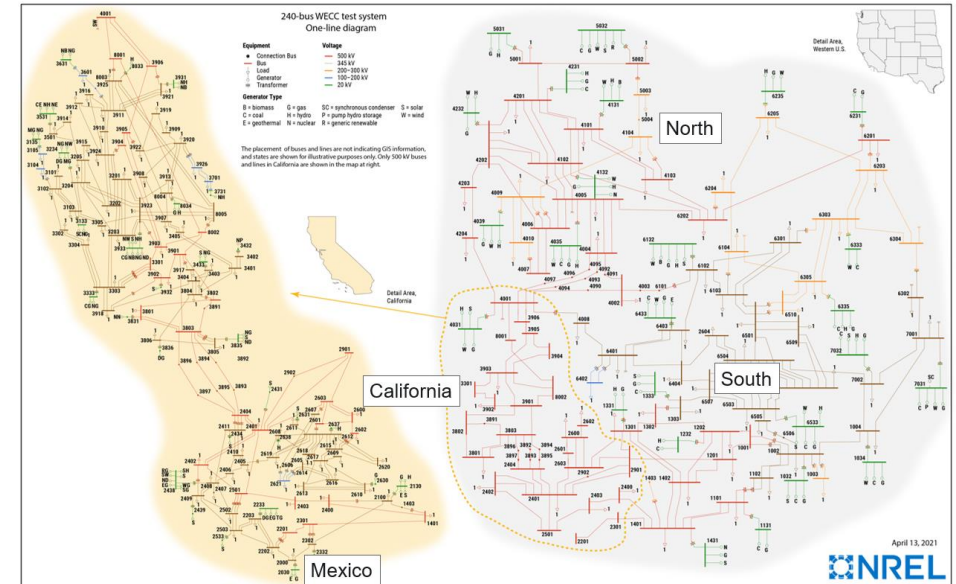

Group #	Description
1	Energy-based methods (DEF, Transient energy,...)
2	Oscillation shape and magnitude (Phase relation at the onset, Magnitude of oscillation, Mode shape)
3	Machine Learning and Model-based analytics (ML pattern recognition, Spectral estimate, ...)
4	Cross Power Spectra Density (energy-based approach is the core)

\* <http://web.eecs.utk.edu/~kaisun/Oscillation/2021Contest/>

# Conclusions Based on Results

Details of implementation could be critical

Energy-based methods are most efficient

Team	1/2	1/2	3	4	5	6	7	8	9	10	11	12	13	14	15	16	17	18	19	20	21	
Score	110	110	99	82	77	76	71	68	62	57	55	44	47	46	45	42	38	37	25	18	17	
Used Method	1	X	X	X	X	X	X	X	X	X	X									X		
	2									X	X					X			X			
	3		X	X	X							X	X	X	X		X	X				X
	4	X																				

Complementary use of ML and Model-based method seems to be beneficial

ML and Model-based method are less efficient

- Methods
- 1: Energy-based
  - 2: Oscillation shape and magnitude
  - 3: Machine Learning and Model-based
  - 4: Cross Power Spectra Density

# OSL Success Stories: Traditional Oscillations

Where	Method	Description
ISO New England (USA)	Energy-based	On-line use since 2017
Power System Operation Corporation (India)	Energy-based	On-line use since 2022
RTDMS by EPG (USA). Commercial product	Energy-based*	Deployed in many utilities but not much information on success stories
Phasorpoint by GE (USA). Commercial product	Phase compass plot	Deployed in many utilities but not much information on success stories

\* Reduced version of energy function implemented in frequency domain



# OSL Success Stories: IBR-based Oscillations

November 21, 2021, Kaua'i Island Power System 18–20 Hz Oscillations

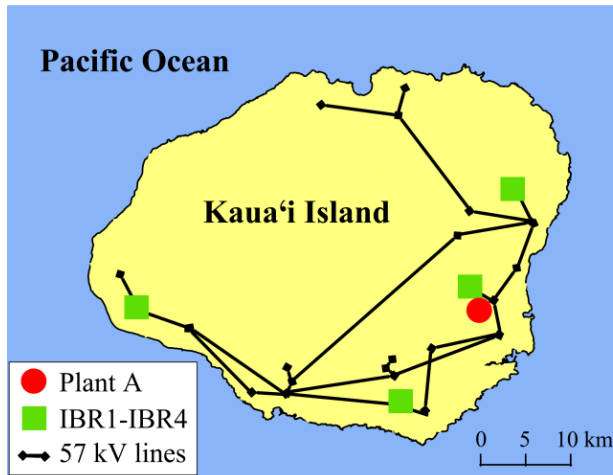
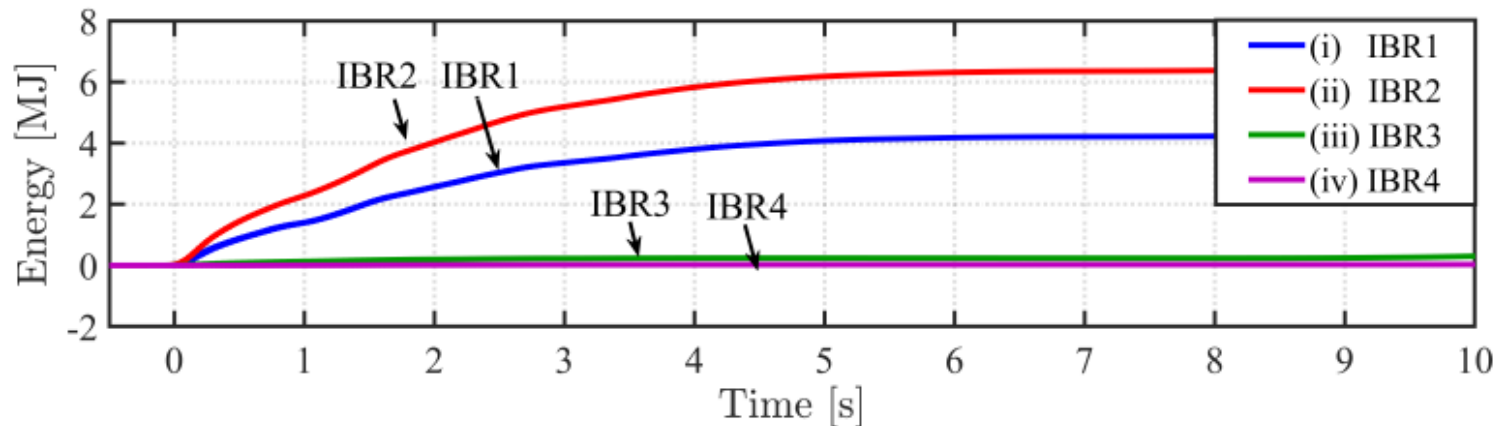
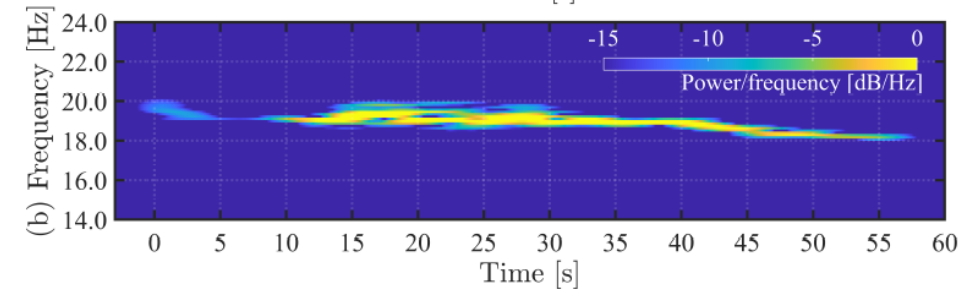
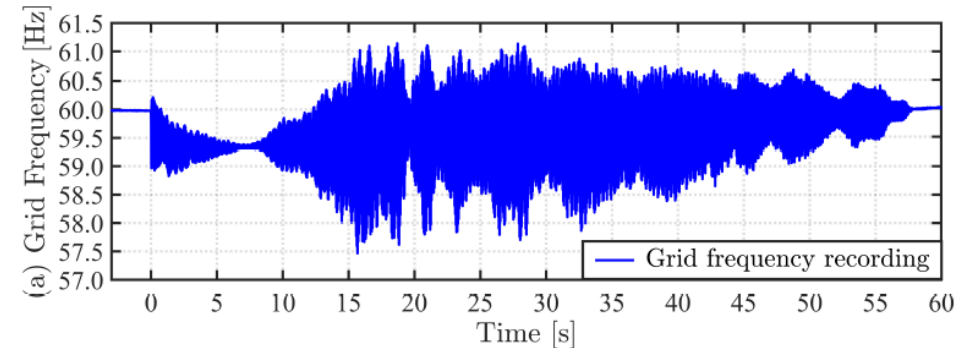

TABLE I  
KIUC GENERATION MIX  
BEFORE AND AFTER EVENT

Time	$t = 0^-$ s	$t = 60$ s
Plant A	60.6%	0.0% ↓
IBR1	4.1%	14.0% ↑
IBR2	4.6%	21.0% ↑
IBR3	0.0%	14.0% ↑
IBR4	4.1%	23.0% ↑
Biomass	13.7%	14.0% ↑
Hydros	13.0%	13.0% —



Identification of oscillation sources with the DEF method

Source: <https://arxiv.org/pdf/2301.05781.pdf>

# Analysis with Impedance Method

- Impedance with (\*) and without (o) the Y Plant

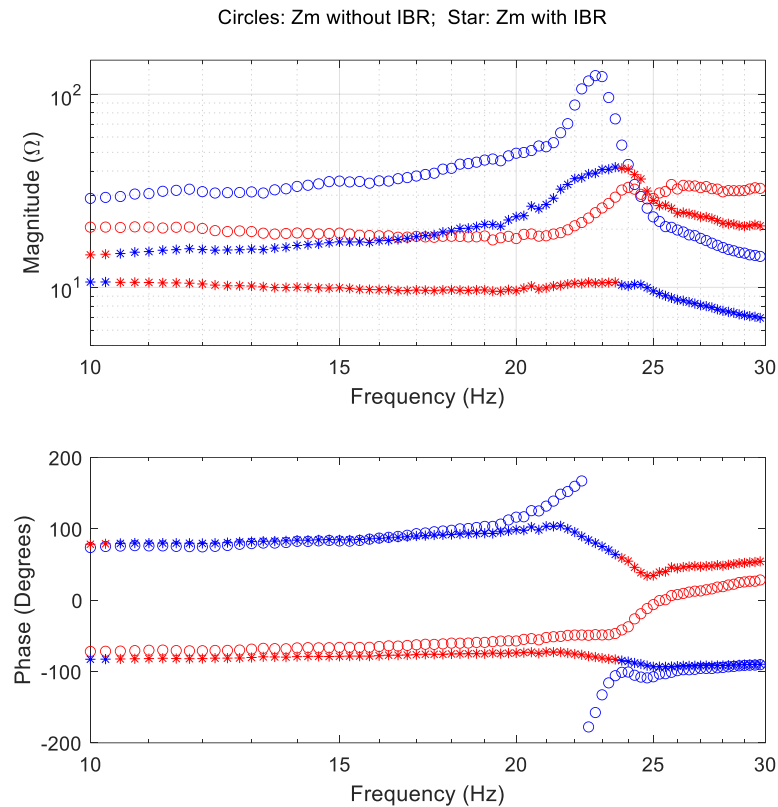

- Nyquist Plot of determinant of  $[I + Z_{\text{netw}}(s)/Z_{\text{plant}}(s)]^{-1}$

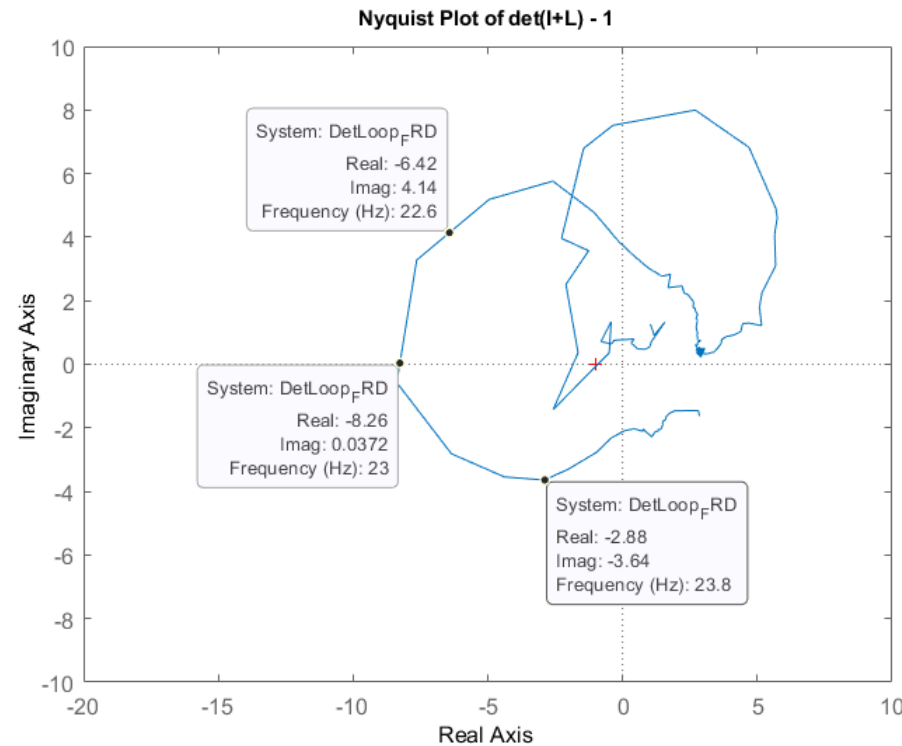

- Analysis Result:*
  - An underdamped resonance mode at 23 Hz is identified
  - The mode is unstable without the Y plant
  - The Y plant holds the system stable

# OSL Success Stories: AEMO

- 11/7/2023 event of 6Hz and 20/9/2023 event of 17 Hz, IBR-related oscillations
- AEMO has obtained a cost-free license of the OSLp software from ISO-NE and benchmarked the algorithm against several simulated and real events
- In EMT simulations, a SSCI event was induced, and measurements recorded by 'virtual' PMUs
- For real events, live PMU data from all available PMUs were utilized
- OSLp software, utilizing the DEF method, has correctly traced the source of oscillation for both simulated and actual events

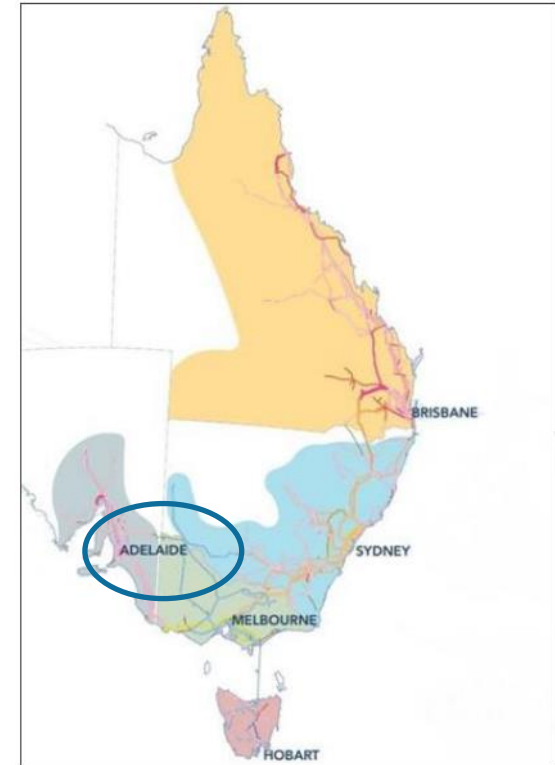

Source: AEMO

# Impedance Scan of Australian Grid from IBR-1

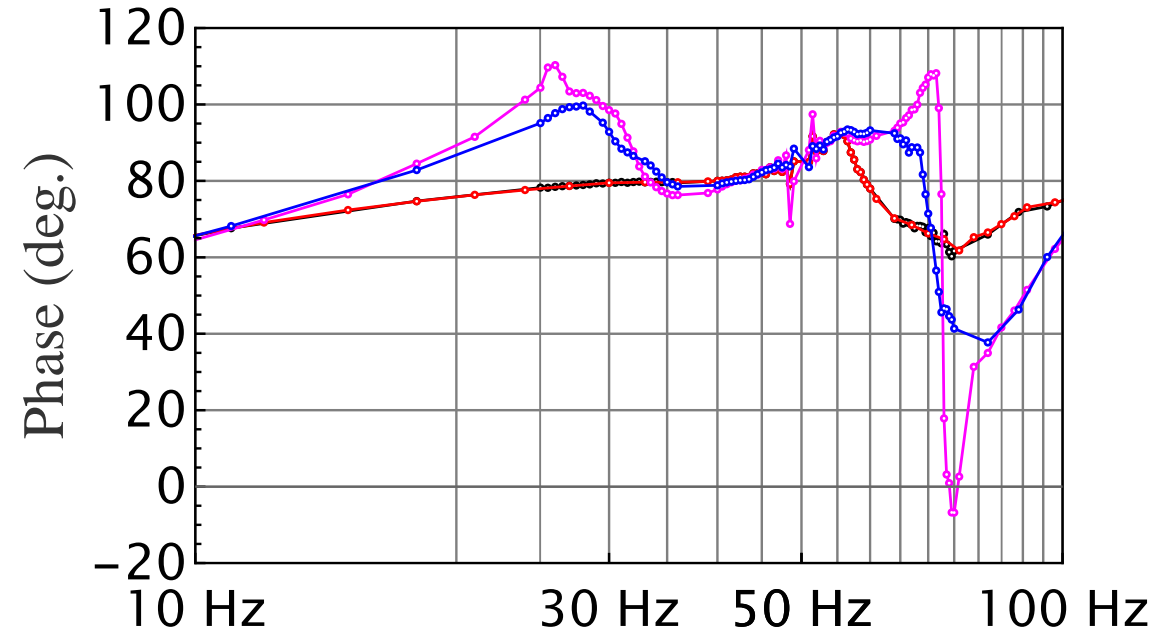
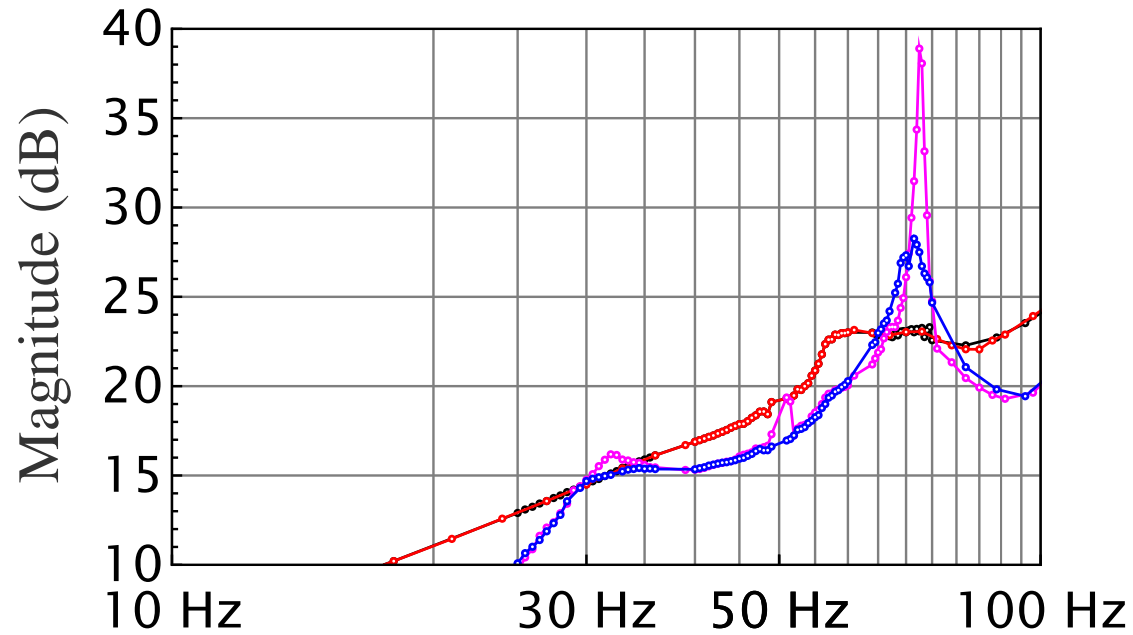

- IBR-2 and IBR-3 are disabled; IBR-2 and IBR-3 operate at low-risk condition; IBR-2 operates at high-risk condition and IBR-3 is disabled; IBR-2 and IBR-3 operate at high-risk condition

# OSL Test Case Library\*

- Contains sets of PMU data for testing OSL methods for **traditional oscillations**
  - ✓ Simulation cases based on WECC 179-bus model
  - ✓ Field-measured cases
  - ✓ IEEE-NASPI contest cases and data set-ups for simulation in 240-bus WECC system
- Creation similar test cases for IBR-based oscillations could be beneficial for benchmarking OSL methods
  - ✓ Models with multiple IBRs
  - ✓ Cases covering all types of oscillations

\* <http://web.eecs.utk.edu/~kaisun/Oscillation/>



# Conclusions

- The effectiveness energy-based tracing method is subject to the consistency between dissipation and damping. This means that different definitions of energy flow are needed to match the types of oscillations.
- New definitions of energy flow need to be investigated to adapt to the behaviours of IBRs.
- The impedance-sensitivity-base tracing method is rather generic but still need black-box EMT model. Extensive to digital-twin being considered.
- Attention is needed on data quality: sampling rate, filtering delay, synchronisation.

Thompson's Economics  
Lecture 10

**Thank You!**

