

IEEE P2800, and What Comes Next?

Draft Interconnection Standard for Large-Scale Solar, Wind, and Energy Storage Plants

Jens Boemer, Principal Technical Leader, EPRI
P2800 Working Group Chair

ESIG 2021 Spring Technical Workshop
Session 4: The Advent of the Inverter Based System

March 11, 2021



This effort is, in part, funded by the Alliance for Sustainable Energy, LLC, Managing and Operating Contractor for the National Renewable Energy Laboratory (NREL) for the U.S. Department of Energy (DOE) under the DOE project "Accelerating Systems Integration Standards II (ACCEL II)" under the grid performance and reliability topic area focusing on the distribution grid.

Why We Are Here.

Circular problem, are we still there?



From: Julia Matevosyan, ERCOT – Introduction Session 3: Grid Forming Inverter Research Landscape, ESIG 2021 Spring Technical Workshop



Adapting to Change and Mobilizing Quickly Enough to Keep Up...

- Sufficient and comprehensive data collection
- Accurate and verified models
- Streamlined interconnection process
- Suitable and adequate studies prior to interconnection
- Ability to accurately identify future reliability issues
- Sufficient time to develop solutions
- Holistic solutions that create resilience
- Ensuring mitigation of boundary-spanning risks

12

RELIABILITY | RESILIENCE |

From: Ryan Quint, NERC – IRPWG Update Session 4: The Advent of the Inverter Based System, ESIG 2021 Spring Technical Workshop

From: Mahesh Morjaria, Terabase Energy – P2800 Update Joint Industry Webinar hosted by SEIA and ACP (AWEA) February 2021

Status Quo -- Solar, Wind & Storage Interconnection Requirements

- Diverse & different requirements across various jurisdictions
...requires more effort and time to address
- Inverter-based resources (IBR) are different from synchronous generators
...higher (and sometimes lower) capability
- Requirements may not be balanced
...some too stringent & not taking advantage of new capability



Source: <https://www.natf.net/>



Adequate Technical Minimum Interconnection Requirements Can Be One Answer

Continuation Model Development, Improvement, and Validation of Inverter-Based Resources

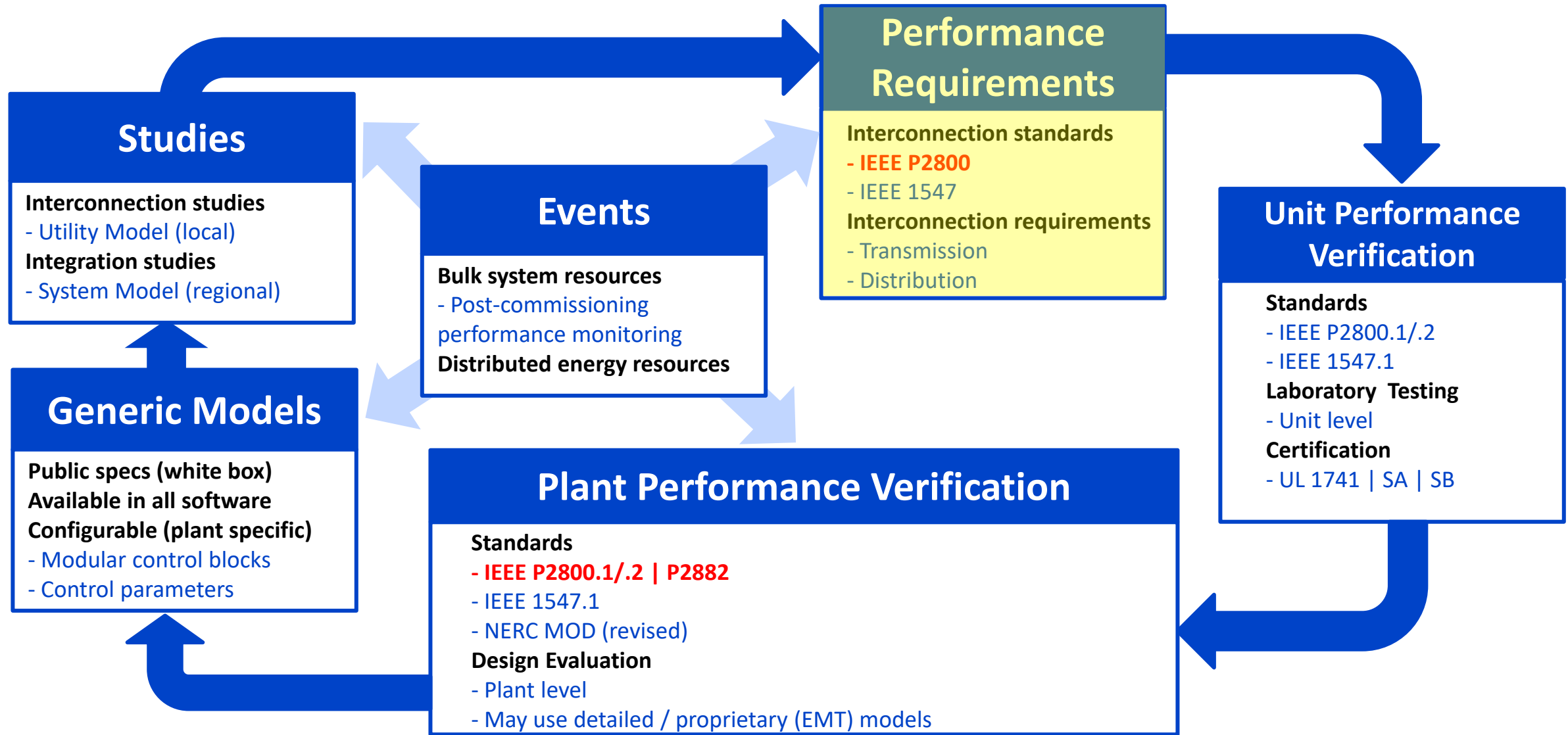

Summary of IEEE P2800 Draft Standard

- The draft standard **harmonizes** Interconnection Requirements for Large Solar, Wind and Storage Plants
- It is a **consensus-based draft** developed by over ~175 Working Group participants from utilities, system operators, transmission planners, & OEMs over 2 years
- You can further **influence** the draft standard by

1) *providing comments via IEEE Public Review* (ends on May 9, 2021)

2) *supporting adoption of the standard*

P2800D6.0, March 2021
Draft Standard for Interconnection and Interoperability of Inverter-Based Resources Interconnecting with Associated Transmission Systems

1 **P2800™/D6.0 (March 2021)**
2 **Draft Standard for Interconnection and**
3 **Interoperability of Inverter-Based**
4 **Resources Interconnecting with**
5 **Associated Transmission Systems**

6 Developed by the
7 Wind and Solar Plant Interconnection Performance Working Group (WSP-IP) – [website](#)
8 of the
9 Energy Development and Power Generation Committee, the Electric Machinery
10 Committee, and the Power System Relaying Committee
11 of the
12 IEEE Power and Energy Society
13

Version	Date	Editor	Comments
Draft 5.0	3/10/2021	Jens C. Boemer (Chair) Marsh Patel	Draft 5.0 for IEEE-SA initial ballot, only changes relate to copyright protected material for which no permission letter was available for the time being.
Draft 5.2	2/1/2021	Jens C. Boemer (Chair) Marsh Patel	Draft 5.2 for IEEE-SA mandatory editorial coordination (MEC), addressing non-substantial WG member comments as well as concerns raised by the Joint Sponsor IEEE/PES Electric Machinery Committee, C50.13 Working Group.
Draft 5.1	12/15/2020	Jens C. Boemer (Chair) All Vice-Chairs	Draft 5.1, final Working Group draft for electronic voting to move towards IEEE-SA balloting – remaining concerns can be addressed in SA ballot. Voting Results: • Approvals: 113 (99%) • Disapprovals: 1 (1%) • Abstentions: 11 • Count: 125 Quorum: yes

14

More Info at <https://sagroups.ieee.org/2800/>

What to expect from IEEE P2800?

■ Provides Value

- widely-accepted, unified technical minimum requirements for IBR
- simplification and speed-up of technical interconnection negotiations
- flexibility for IBR plant developers → not an equipment design standard

■ Specifies

- performance and functional capabilities *and not* utilization & services
- functional default settings and ranges of available settings
- performance monitoring and model validation
- type of tests, plant-level evaluations, and other verifications means, but not detailed procedures (→ *IEEE P2800.1 and/or P2800.x*)

■ Scope

- Limited to all transmission and sub-transmission connected, large-scale wind, solar, energy storage and HVDC-VSC

How IEEE P2800 May Complement North American Electric Reliability Standards & Guidelines

		Performance	Test & Verification & Model Validation
FERC / NERC?	Transmission	<ul style="list-style-type: none"> • FERC Orders • NERC Reliability Standards & Guidelines 	<ul style="list-style-type: none"> • NERC compliance monitoring & enforcement
	Sub-Transmission	<ul style="list-style-type: none"> • Not available 	<ul style="list-style-type: none"> • Not available
NARUC / State PUCs?	Distribution (for DER)	<ul style="list-style-type: none"> • IEEE 1547-2018 ✓ • IEEE 1547a-2020 ✓ 	<ul style="list-style-type: none"> • IEEE 1547.1-2020 ✓ • UI 1741 (SB) ✓ • IEEE ICAP ✓

DER: Distributed Energy Resources

When adopted by the appropriate authority (e.g., Transmission Owners, NERC, FERC), IEEE standards become mandatory

IEEE P2800 Consensus Technical Minimum **Capability** Requirements

>99% Approval

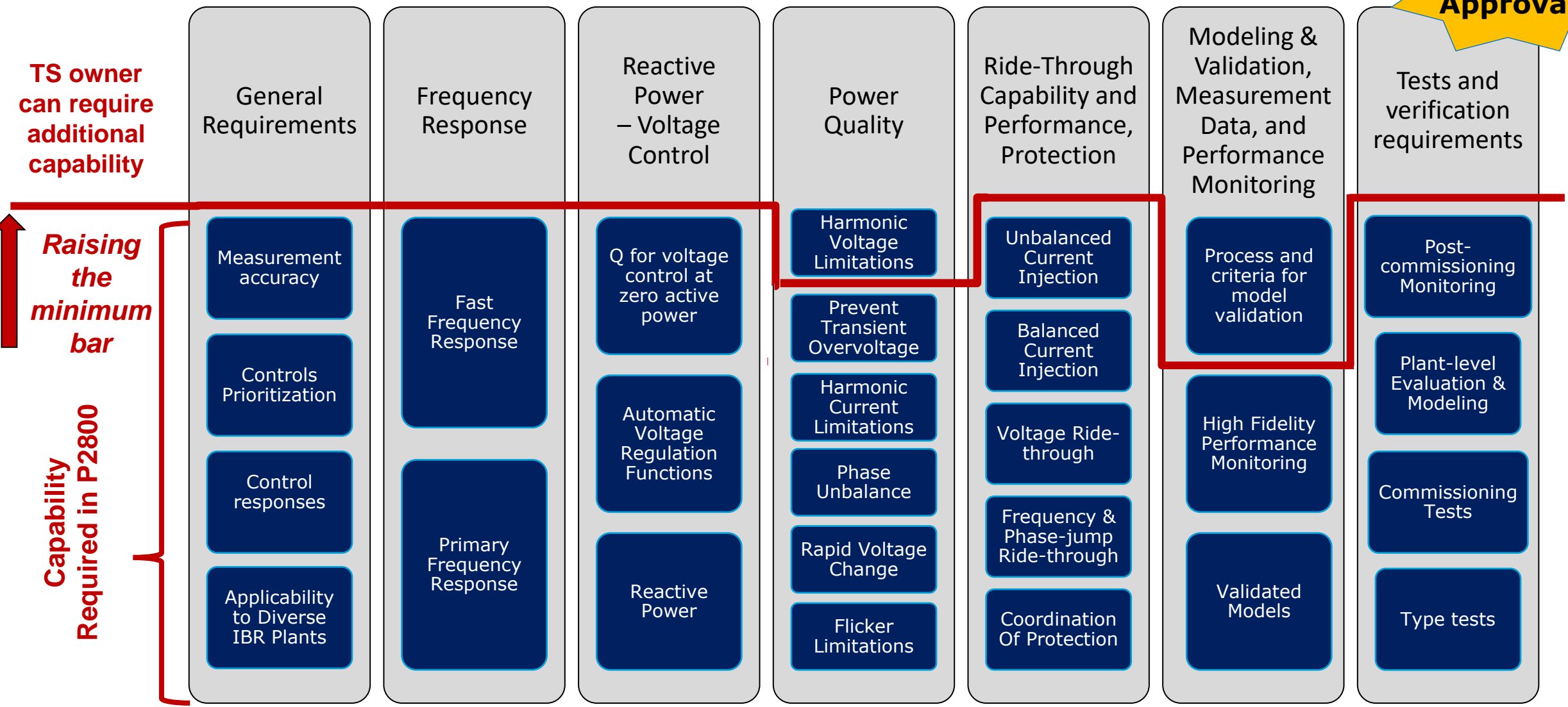

Utilization of these capabilities is outside the purview of P2800

Anticipated Timeline, and What Comes Next?

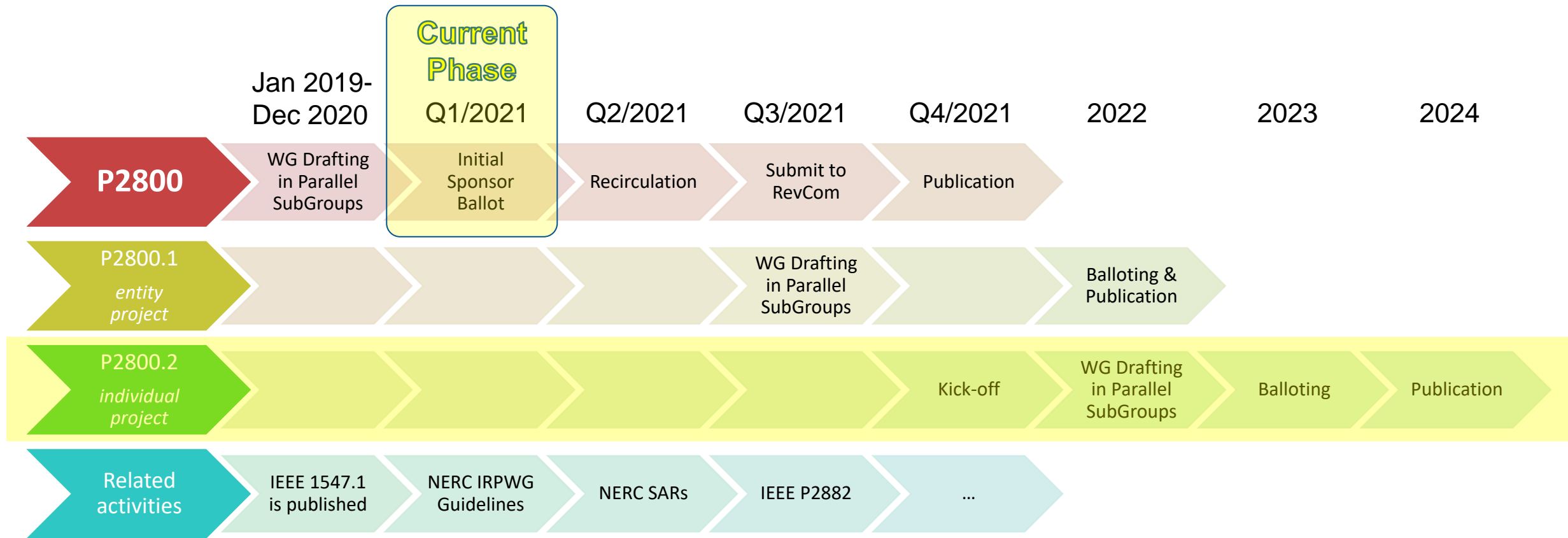

As soon as IEEE P2800 has been successfully balloted, the drafting of conformance procedures will commence in projects like IEEE P2800.1, P2800.2, and P2882.

IEEE P2800 Clause 12 (Test and Verification) Framework

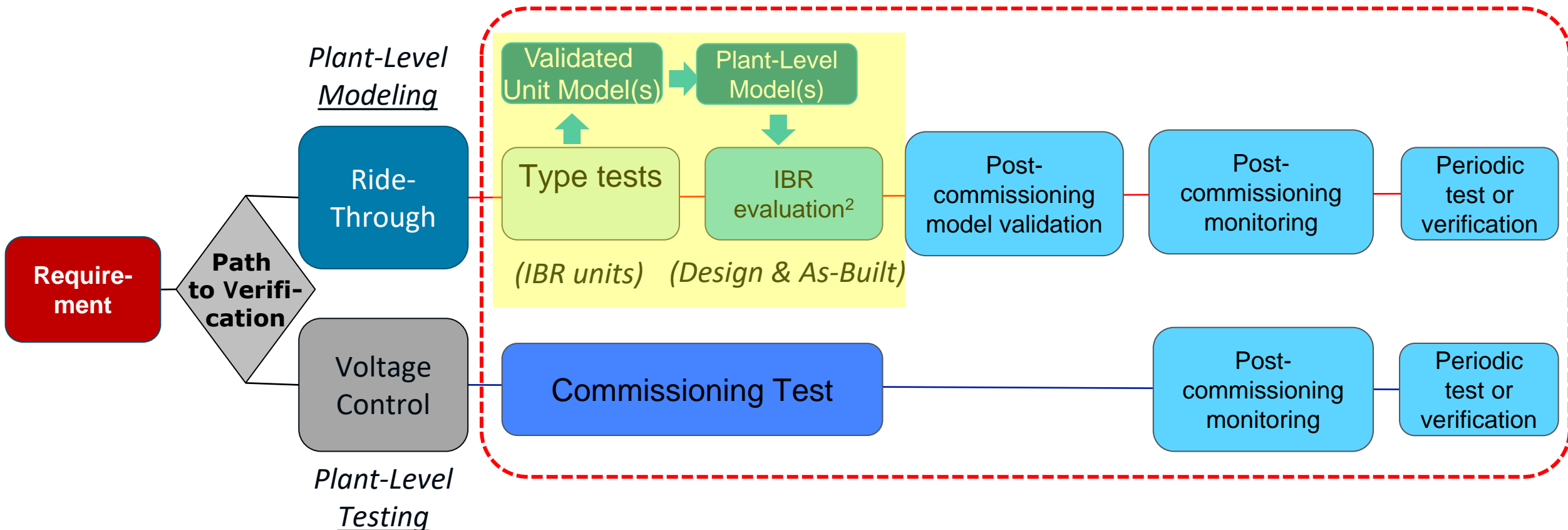
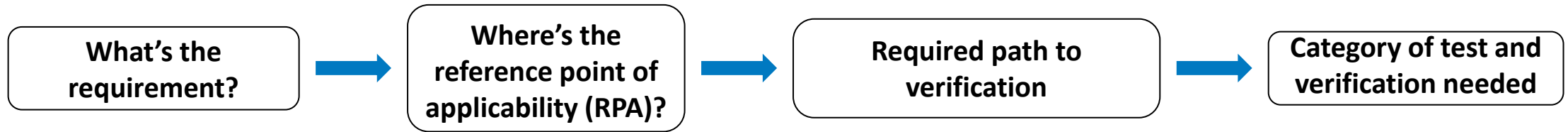

A Potential Future? One Streamlined Model Application Example

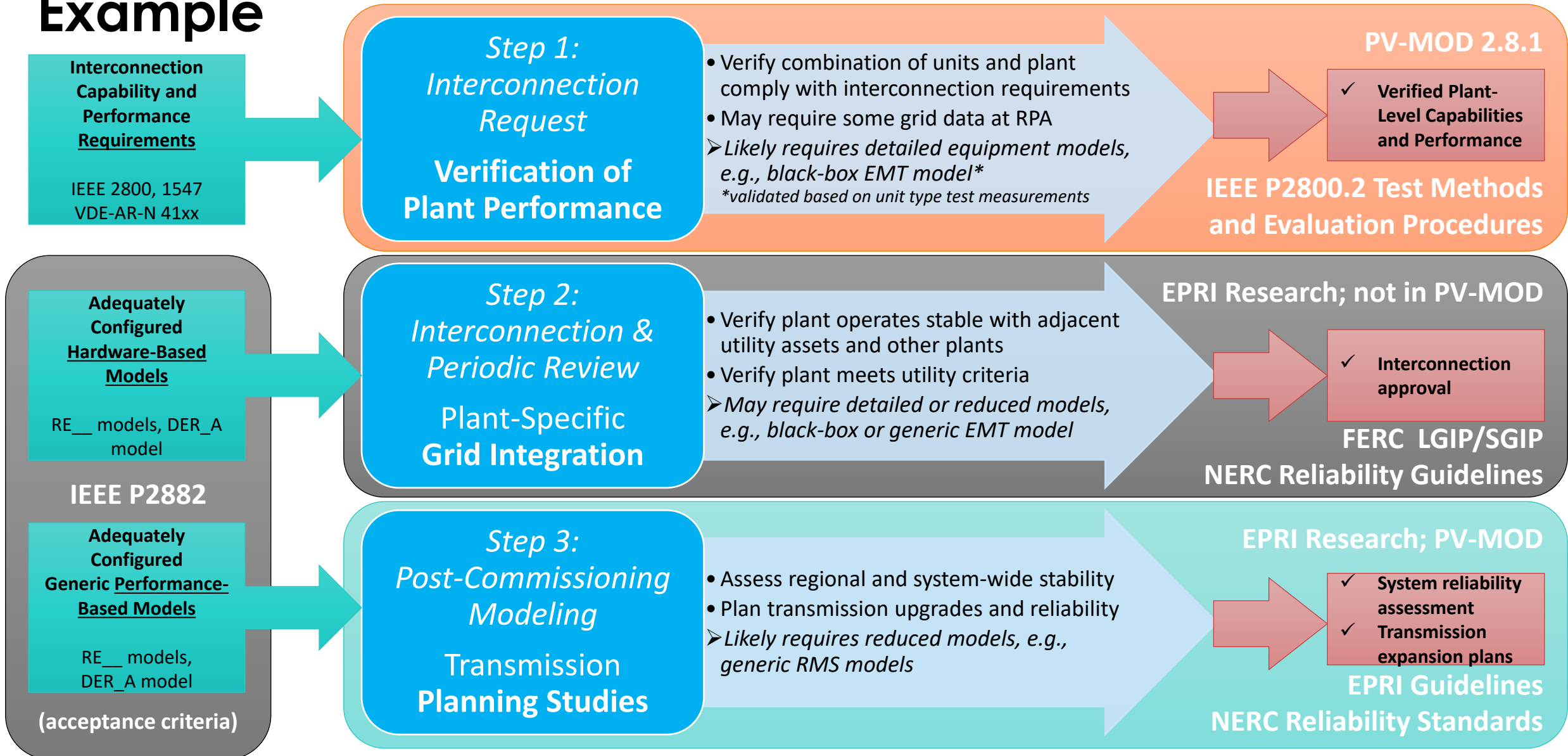

Questions & Answers | Discussion

- *Would IEEE 2800 apply to offshore wind plants?*
- *Clarify “nature” of ride-through requirements?*
- *Is fast frequency response capability needed for all IBRs?*
- *How could a plant-level performance verification look like?*
- *Why are there no requirements for IBR interconnection to low system strength?*
- ...



Contact: Jens Boemer

jboemer@epri.com | 206.471.1180

A blue-tinted photograph of four people, two men and two women, standing together. They are wearing white lab coats or polo shirts with the EPRRI logo. One woman is wearing a white hard hat. They appear to be in a professional setting, possibly a laboratory or office, and are looking towards the camera with slight smiles. The background is a solid blue color.

Together...Shaping the Future of Electricity

IEEE-SA Sponsor Ballot & Public Review

- IEEE SA Ballot Group invitation was sent to >2,500 subject matter experts within IEEE societies and their committees
- Formed a **balanced ballot group with 466 balloters**
 - **Initial ballot ends on April 10, 2021**, draft is available to balloters on myProject at <https://development.standards.ieee.org/>
 - **Public review ends on May 9, 2021**, search for “2800” at <https://publicreview.standards.ieee.org/>
- More information is available on the P2800 website at <https://sagroups.ieee.org/2800/members/>
- Upcoming **Milestones:**

Milestone: SA Initial Ballot + Public Review	March 10, 2021 (31 days for SA ballot, WG/CRG resolves comments, 60 days for public review)
Recirculation 1	June 2021* (10 days + comment resolution)
Recirculation 2	July 2021* (10 days + comment resolution)
Recirculation n-th	Aug 2021* (10 days + comment resolution)
Milestone: Submission to RevCom	Aug 13 / Sep 10 / Oct 18, 2021*
Milestone: Publication	December 2021*

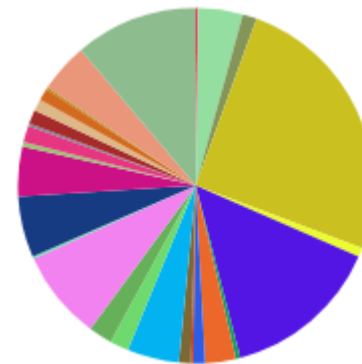
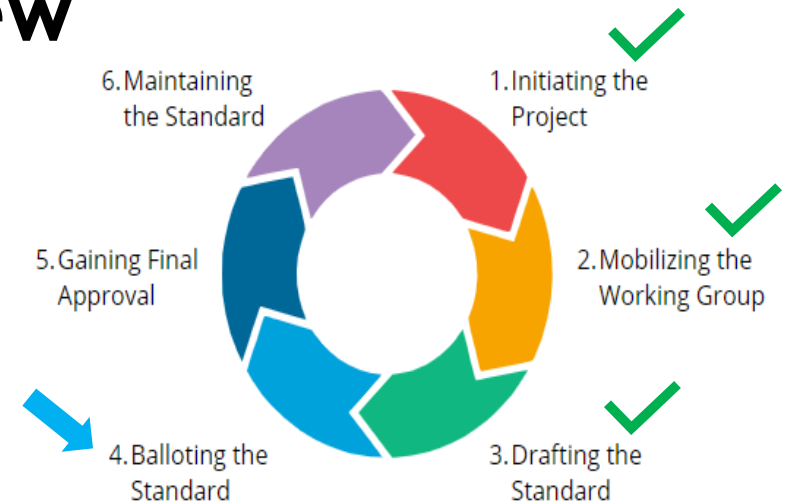

466 Balloters

TOP 10 Balloter Groups (n=466)

1. Consulting (25%)
2. General Interest (14%)
3. Other (11%)
4. Producer – System / Manufacturer (8%)
5. Research (6%)
6. Service Provider – Design Services (5%)
7. Producer – Component (5%)
8. User – Industrial (5%)
9. Academic – Researcher (4%)
10. Government (3%)

Consensus =

- $\geq 75\%$ Quorum
- $\geq 75\%$ Approval
- *WG Chair's goal is $\geq 90\%$!*

Comparison of P2800 Initial Ballot Draft with IEEE 1547-2018

Legend: X Prohibited, √ Allowed by Mutual Agreement, ‡ Capability Required, (‡) Procedural Step Required as specified, Δ Test and Verification Defined

Function Set	Advanced Functions Capability	IEEE 1547-2018	IEEE P2800
General	Adjustability in Ranges of Allowable Settings	‡	‡
	Prioritization of Functions	‡	‡
Monitoring, Control, and Scheduling	Ramp Rate Control		
	Communication Interface	‡	‡
	Disable Permit Service (Remote Shut-Off, Remote Disconnect/Reconnect)	‡	‡
	Limit Active Power	‡	‡
	Monitor Key DER Data	‡	‡
	Remote Configurability	‡	‡
	Set Active Power		‡
	Scheduling Power Values and Models		√
Reactive Power & (Dynamic) Voltage Support	Constant Power Factor	‡	‡
	Voltage-Reactive Power (Volt-Var)	‡	‡
	Autonomously Adjustable Voltage Reference	‡	
	Capability at zero active power (“VARs at night”)		‡
	Active Power-Reactive Power (Watt-Var)	‡	
	Constant Reactive Power	‡	‡
	Voltage-Active Power (Volt-Watt)	‡	
	Dynamic Voltage Support during VRT	√	‡
	Unbalanced Dynamic Voltage Support during VRT		‡

Function Set	Advanced Functions Capability	IEEE 1547-2018	IEEE P2800
Bulk System Reliability & Frequency Support	Frequency Ride-Through (FRT)	‡	‡
	Rate-of-Change-of-Frequency Ride-Through	‡	‡
	Voltage Ride-Through (VRT)	‡	‡
	Transient Overvoltage Ride-Through	‡	‡
	Consecutive Voltage Dip Ride-Through	‡	‡
	Voltage Phase Angle Jump Ride-Through	‡	‡
	Frequency-Watt	‡	‡
	Fast Frequency Response / Inertial Response	√	‡
	Return to Service (Enter Service)	‡	‡
	Black Start	√	√
Protection & Power Quality	Abnormal Frequency Trip	‡	√
	Abnormal Voltage Trip	‡	√
	Unintentional Islanding Detection and Trip	‡	√
	Limitation of DC Current Injection	‡	
	Limitation of Voltage Fluctuations	‡	‡
	Limitation of Current Distortion	‡	‡
	Limitation of Voltage Distortion		√
	Limitation of (Transient) Overvoltage	‡	‡
Test, Verification, Modeling & Measurements	Provision of Verified Models		(‡)
	Collection of Measurement Data	(‡)	(‡)
	Type Tests	(‡)	(‡)
	Production Tests	(‡)	
	Plant-Level Design Evaluation	(‡)	(‡)
	Commissioning Tests	(‡)	(‡)
	Model Validation		(‡)
	Performance Monitoring		(‡)
	Periodic Tests	(‡)	(‡)
	Periodic Verification	(‡)	(‡)

Clause 12 (Test and Verification) Framework

Potential Benefits

- Raising the bar of existing plant-level capability and performance verification procedures.
- Reducing the uncertainty of plant-level performance.
 - The smaller the grid, the higher the impact of uncertainty.
- Improve the validity and accuracy of plant-level models and their parameterization.

Potential Challenges

- Does not replace engineering judgement and experience.
- Could create a false perception of modeling accuracy.
- Finding the right balance between standardization and flexibility.

Way forward

- Recommended Practice
- IEEE P2800.2 and P2882

Related IEEE Standard Association activities

P2800.2: Recommended Practice for Test and Verification Procedures for Inverter-based Resources (IBRs) Interconnecting with Bulk Power Systems

- Type: recommended practice, individual project
- Sponsor(s): IEEE/PES/EDPG+EMC+PSRC+AMPS
- Tentative timeline: June 2023 (initial ballot), Dec 2023 (RevCom approval)
- Scope: recommends leading practices for test and verification procedures that should be used to confirm plant-level conformance of IBRs interconnecting with BPSs under IEEE Std 2800.
 - complements the IEEE 2800 test and verification framework with specifications for the equipment, conditions, tests, modeling methods, and other verification procedures
 - may specify design and as-built evaluations procedures for verification of plant-level capabilities and performance
 - may also specify verification procedures for IBR plant-level generic models applied for different time frames including S/C models, RMS models, and EMT models

P2882: Guide for Validation of Software Models of Renewable and Conventional Generators for Power System Studies

- Type: guide, individual project
- Sponsor(s): IEEE/PES/AMPS+EMC+EDPG
- Tentative timeline: Dec 2021 (initial ballot), Dec 2022 (RevCom approval)
- Scope: guidelines for the validation of software models for renewable and conventional generators used for power system studies.
 - ... ‘validation’ is a procedure and set of acceptance criteria ... to confirm that the models perform well numerically and provide the intended response(s).
 - does not cover ... validation of generator software models against field measurements and other types of site or factory tests

DOE PV-MOD

Validated; publicly available models for various types of studies, reports detailing the research, close collaboration with industry stakeholders (NERC, WECC, IEEE, etc.)

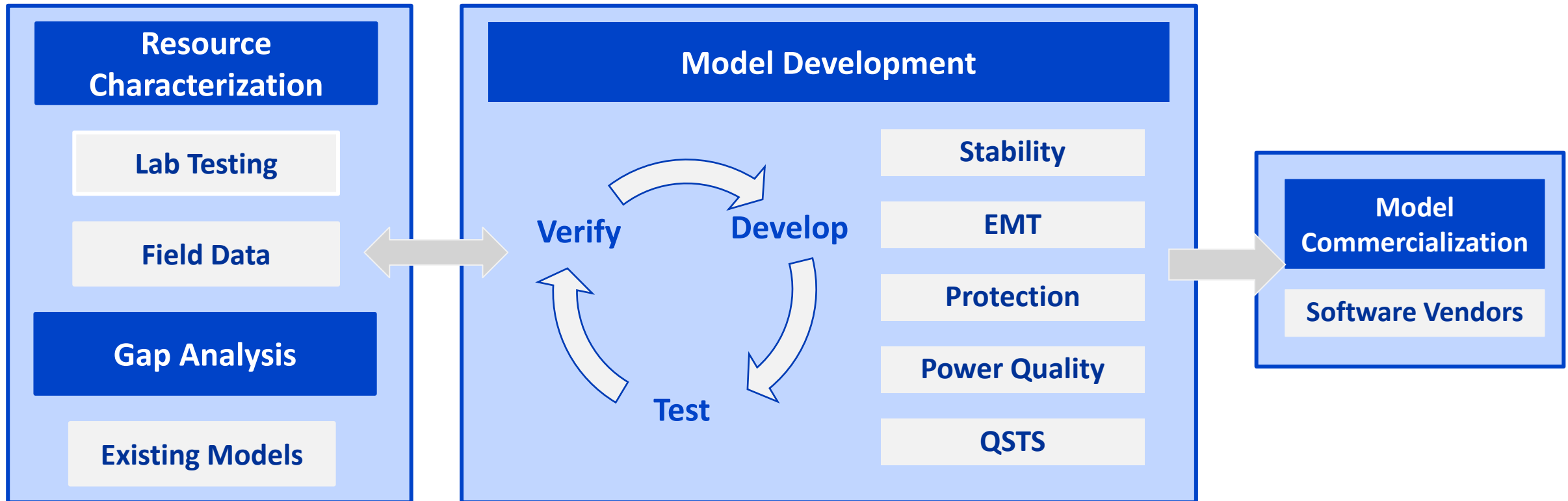

Additional IEEE P2800 Slides

IEEE Standards Classification and Consensus Building

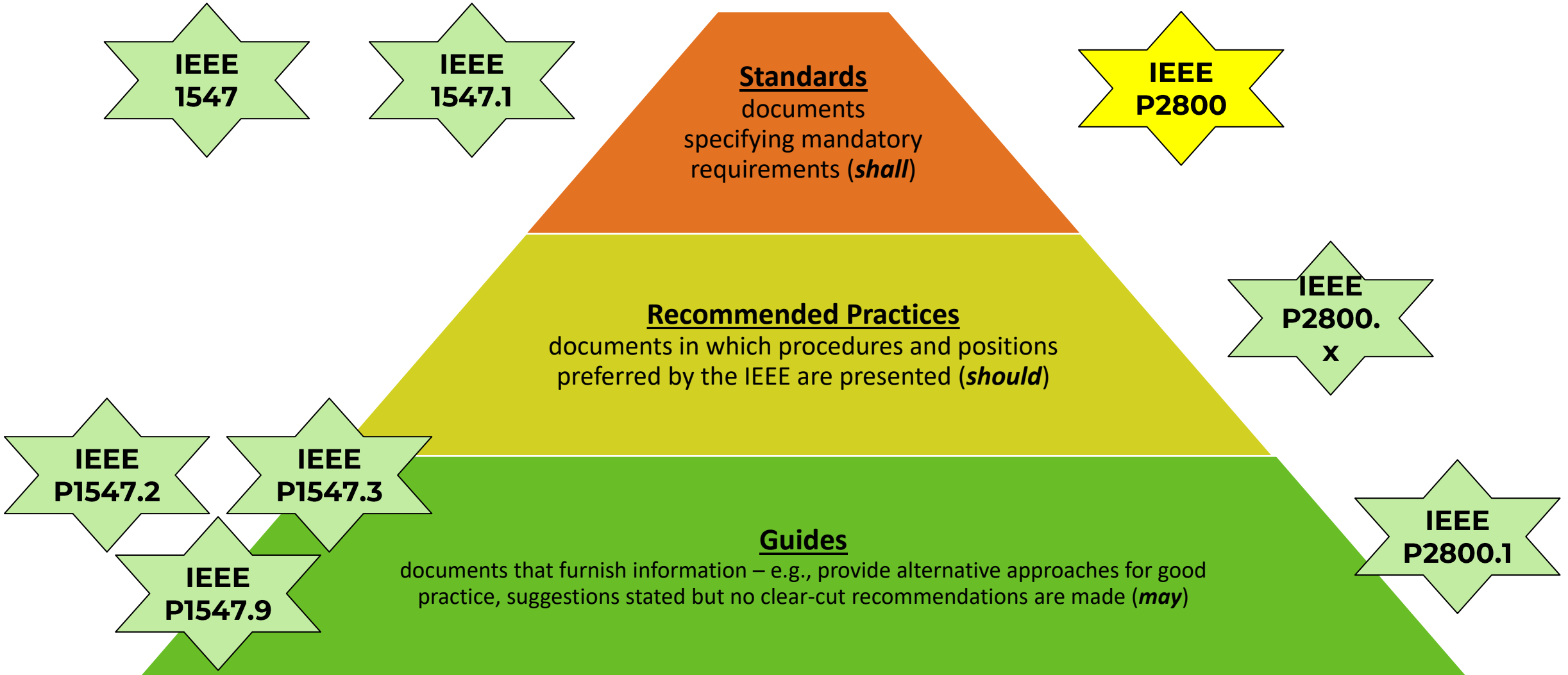

Examples for Inverter-Bases Resources (IBR) Plants

in scope

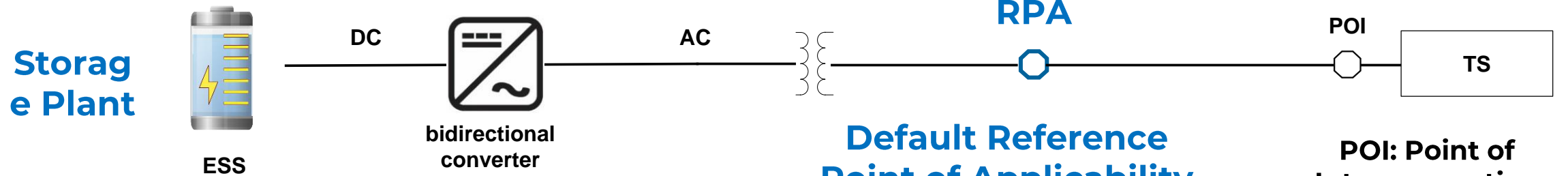
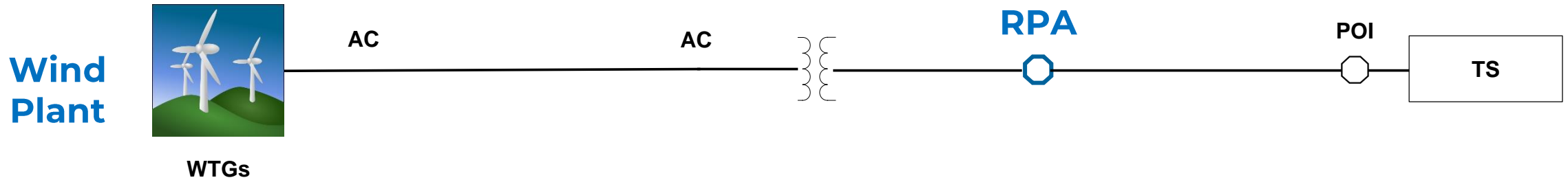
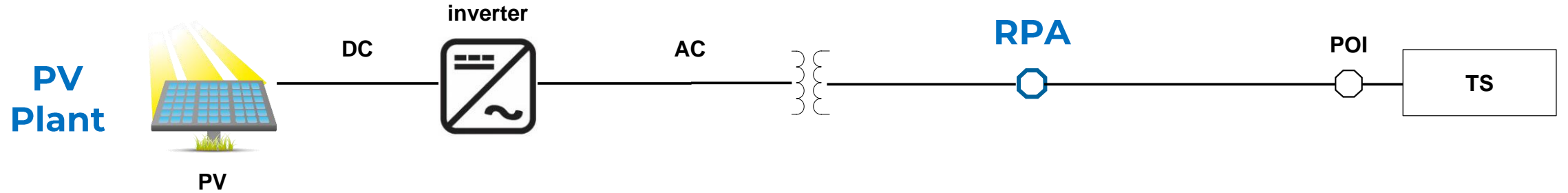

Default Reference Point of Applicability (RPA) is Point of Measurement (POM)

POI: Point of Interconnection System
TS: Transmission System

Example *hybrid IBR plant, ac-coupled*

in scope

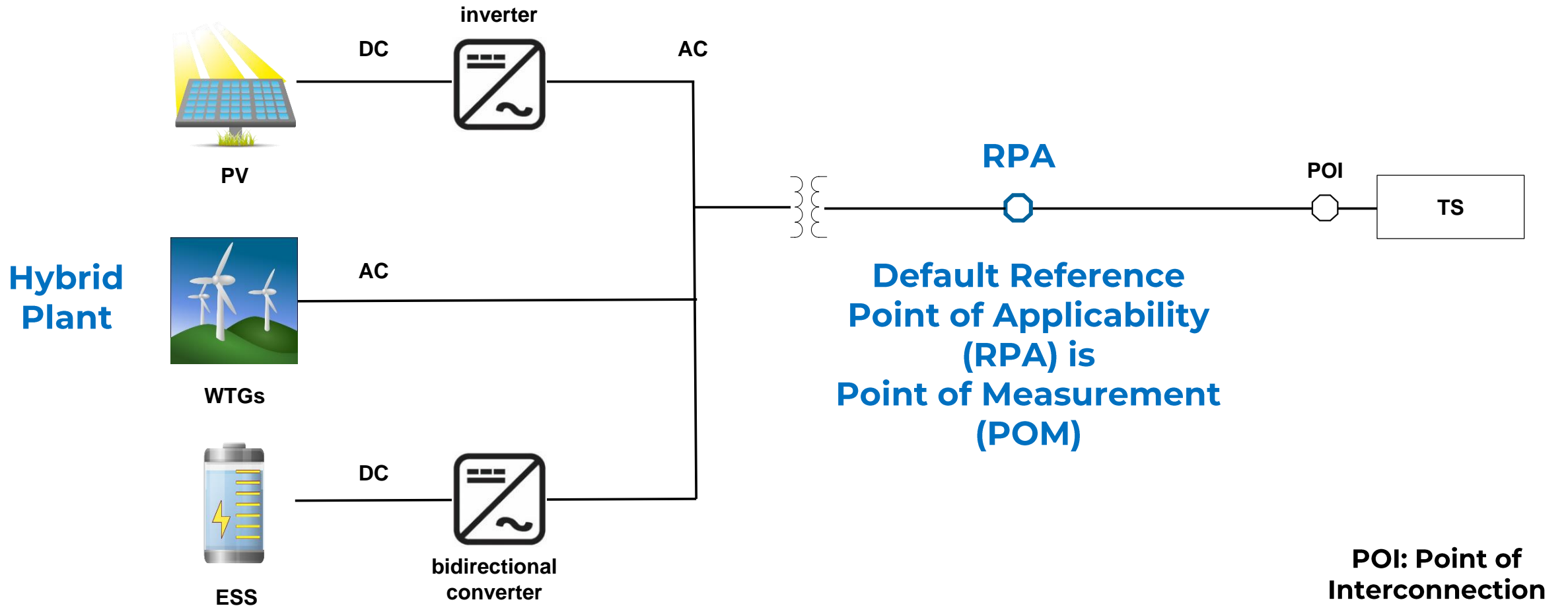

**Default Reference
Point of Applicability
(RPA) is
Point of Measurement
(POM)**

**POI: Point of
Interconnection
TS: Transmission
System**

Example *hybrid plant*: operated as a single resource

in scope

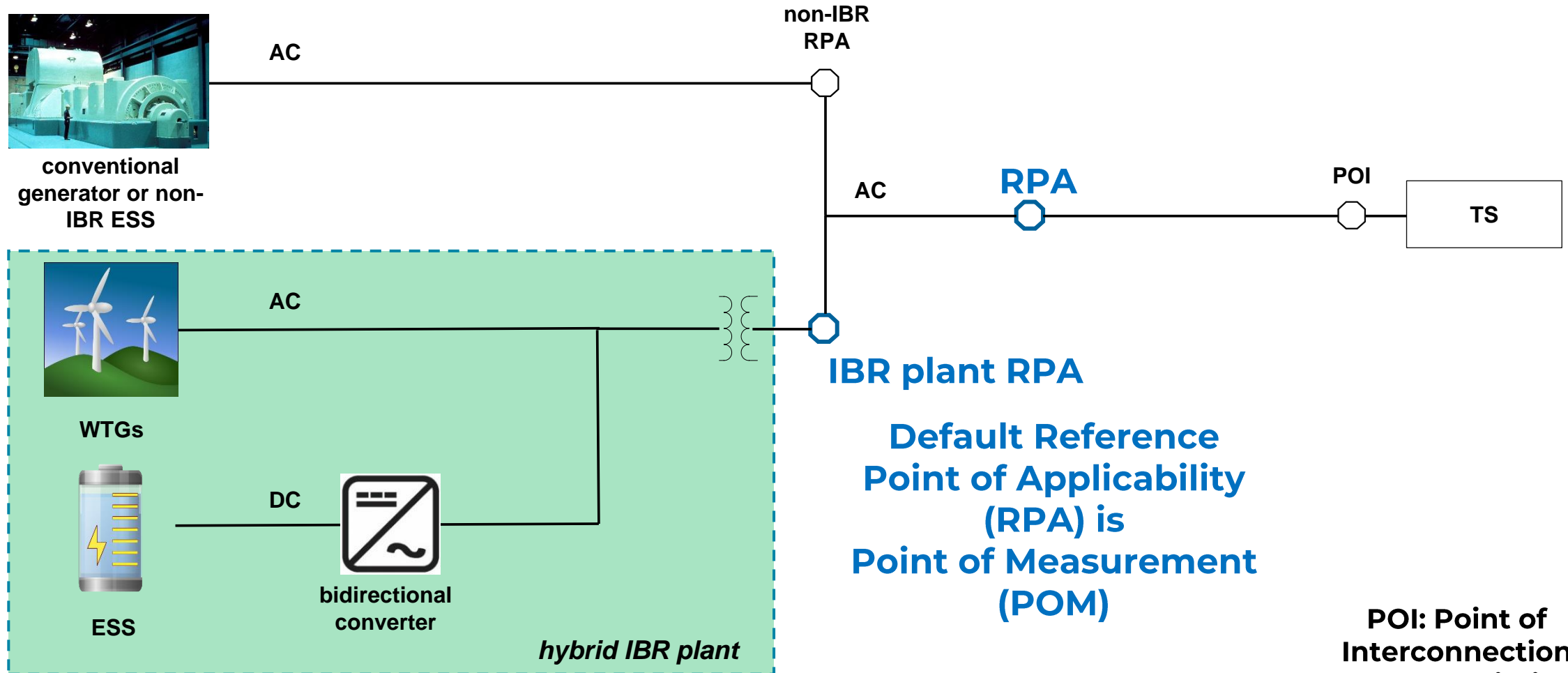

POI: Point of Interconnection
TS: Transmission System
IEEE

Approximately 300 Interested Parties and 175+ WG Members

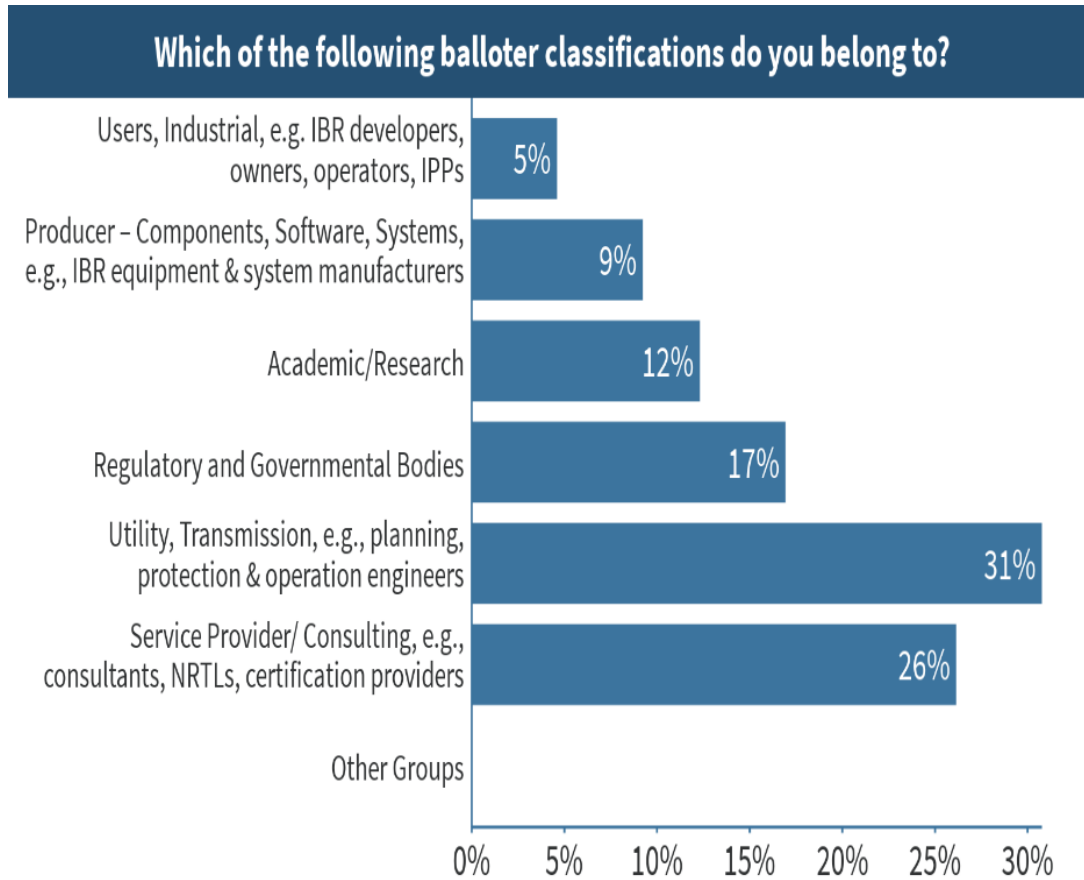

Broad Collaboration & Coordination

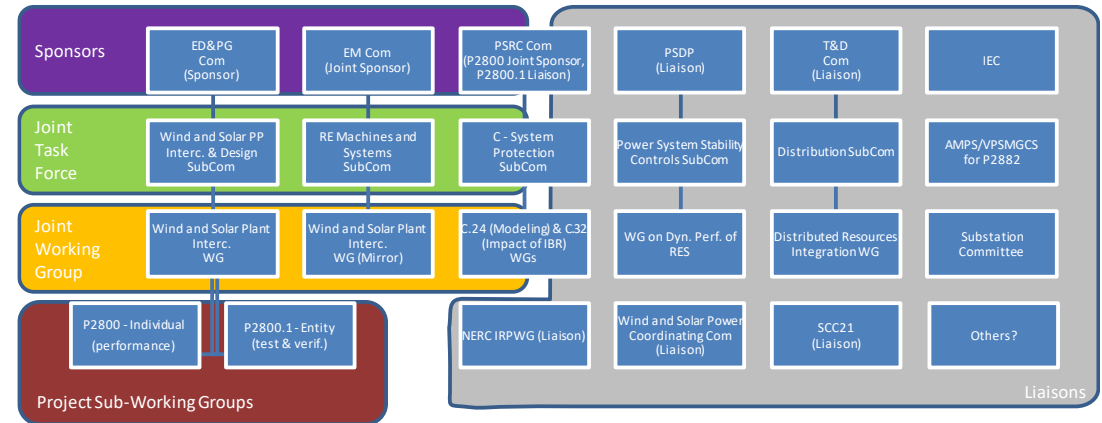

- IEEE/PES/EDPG Main Sponsor
- IEEE/PES/EMC & PSRC Joint Sponsors
- HVDC-VSC Subject Matter Experts
- IEEE/PES/Substations Committee SMEs
- IEEE/PES/Analytic Methods for Power Systems (AMPS) SMEs
- NERC Inverter-Based Resources Performance WG SMEs

Scope and Language of P2800 Requirements

3.

1. Standard
("shall", "may")

2. Standard Informative
("should")¹ Appendix
("may")¹

Important Terms

- **point of connection (POC)**
 - IBR unit terminals
- **point of measurement (POM)**
 - IBR plant
- **point of interconnection (POI)**
 - interconnection system
 - IBR tie line
- **transmission system (TS)**
 - Transmission
 - Sub-transmission
- **supplemental IBR device**
 - Compensation
 - Plant controller
 - Etc.

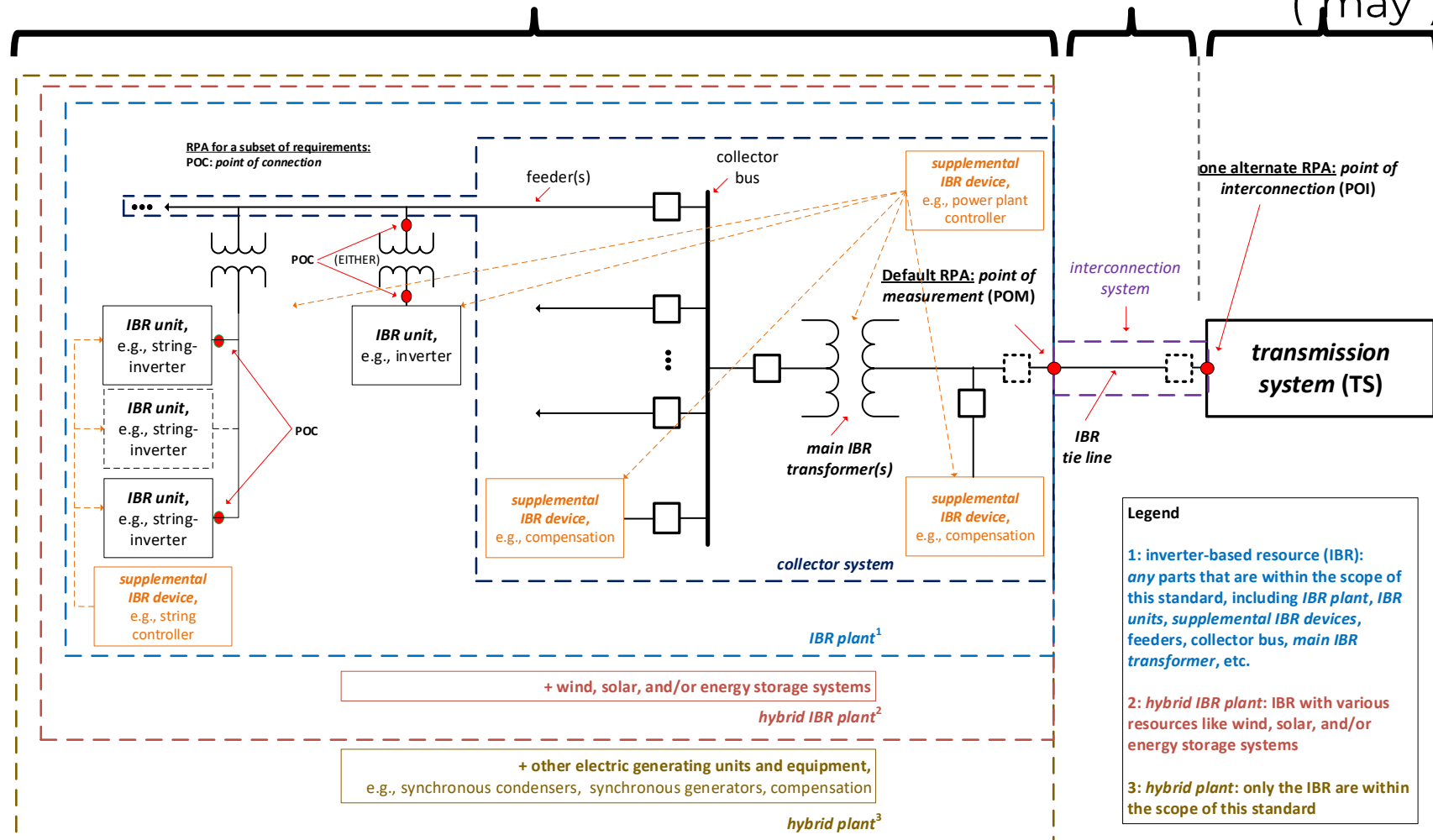

¹if available, refer to existing IEEE documents

Legend

1: inverter-based resource (IBR): any parts that are within the scope of this standard, including IBR plant, IBR units, supplemental IBR devices, feeders, collector bus, main IBR transformer, etc.

2: hybrid IBR plant: IBR with various resources like wind, solar, and/or energy storage systems

3: hybrid plant: only the IBR are within the scope of this standard

Scope and Language of P2800 Requirements

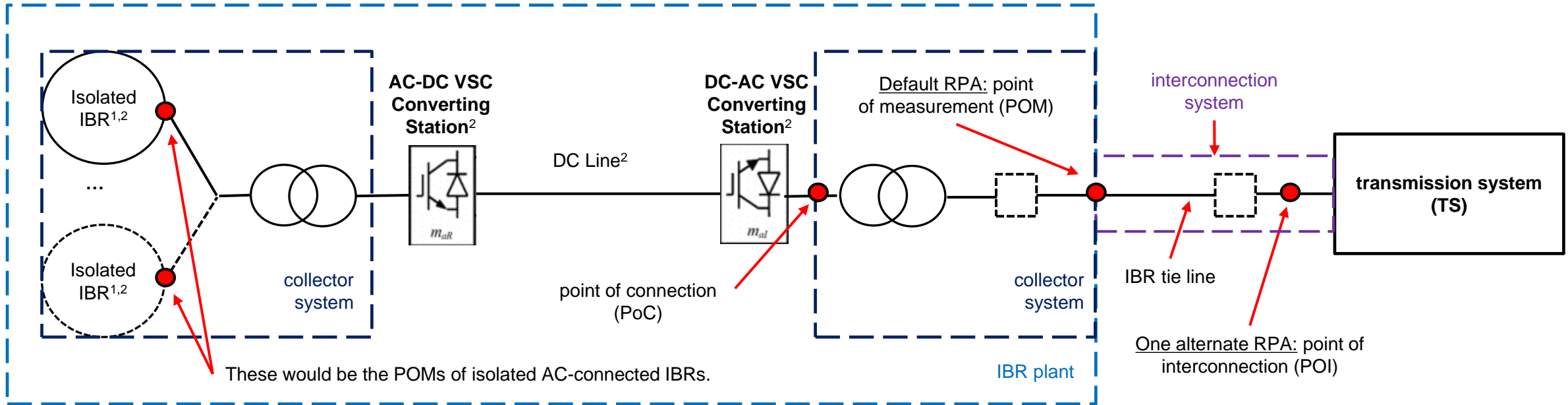

¹ Includes IBR units like type IV wind turbine generators

² May serve as a supplemental IBR device that is necessary for the IBR plant with HVDC-VSC to meet the requirements of this standard at the RPA

In Scope

- “Shall” requirements for isolated IBR connected via dedicated HVDC-VSC link
- “May” requirements for non-IBR resources connected via dedicated HVDC-VSC link

Out of Scope

(no “shall” requirements, “may” at discretion of *TS owner*)

- Isolated non-IBR connected via dedicated HVDC-VSC link
 - Manitoba Hydro: Pole 3 at Dorsey
- HVDC-VSC that connect two points in a synchronous area
- Any interconnections involving HVDC-LLC

Voltage And Reactive Power Control Modes

The *IBR plant* shall provide the following mutually exclusive modes of reactive power control functions:

- RPA voltage control mode
- Power factor control mode
- Reactive power set point control mode

RPA voltage control

- Closed-loop automatic voltage control mode to regulate the voltage at the RPA
- Stable response & any oscillations shall be positively damped (>0.3 damping ratio)
- Capable of reactive power droop to ensure a stable and coordinated response

Parameter	Performance Target	Notes
Reaction Time	<200 ms	
Maximum Step Response Time	As Required by TS Operator	range between 1 s and 30 s
Damping	Damping ratio of 0.3 or better	

Reactive power (Q) capability at RPA vs Active Power

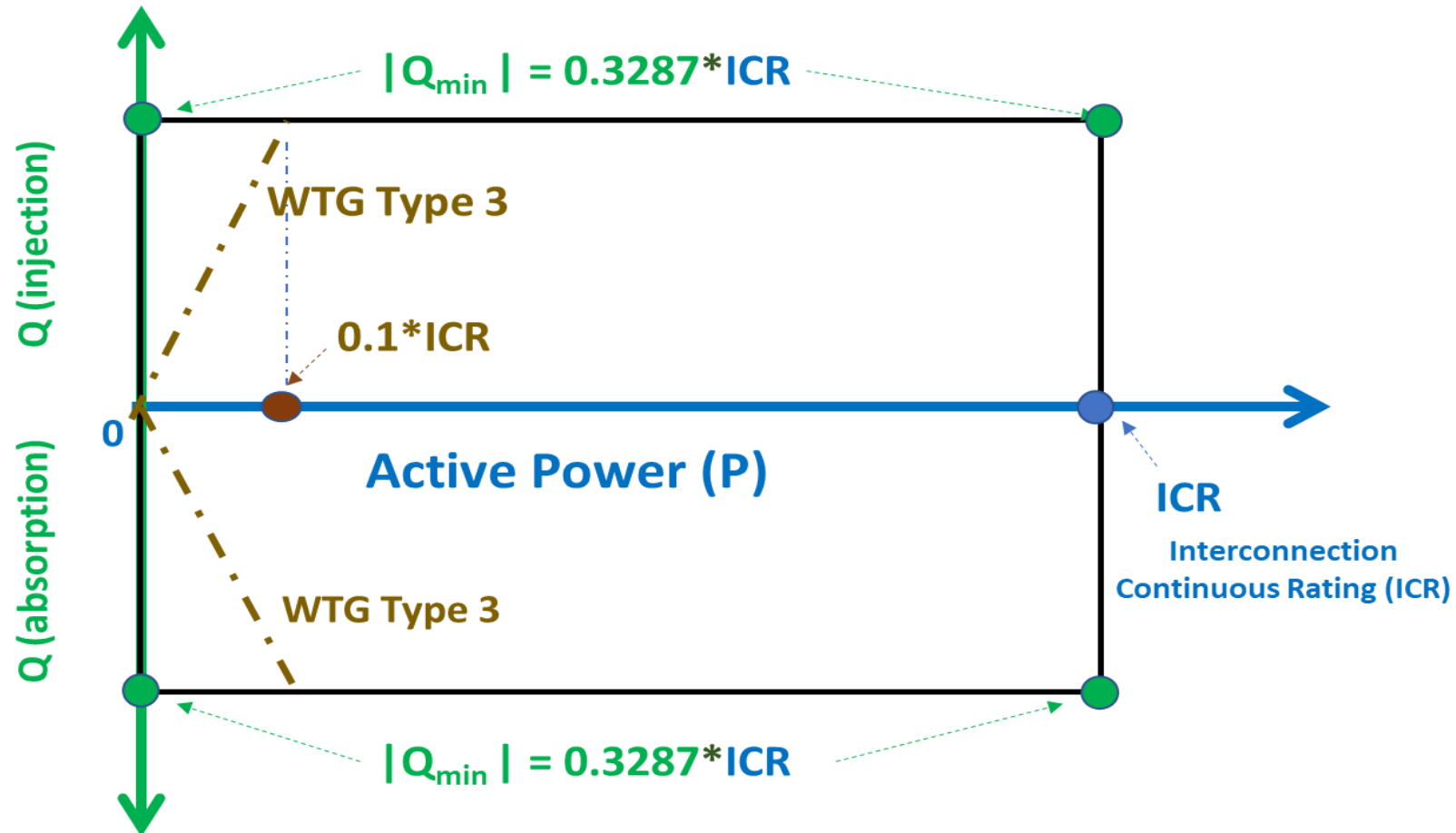

0.3287: Equivalent to 0.95 PF

Reactive power (Q) capability at RPA vs Active Power

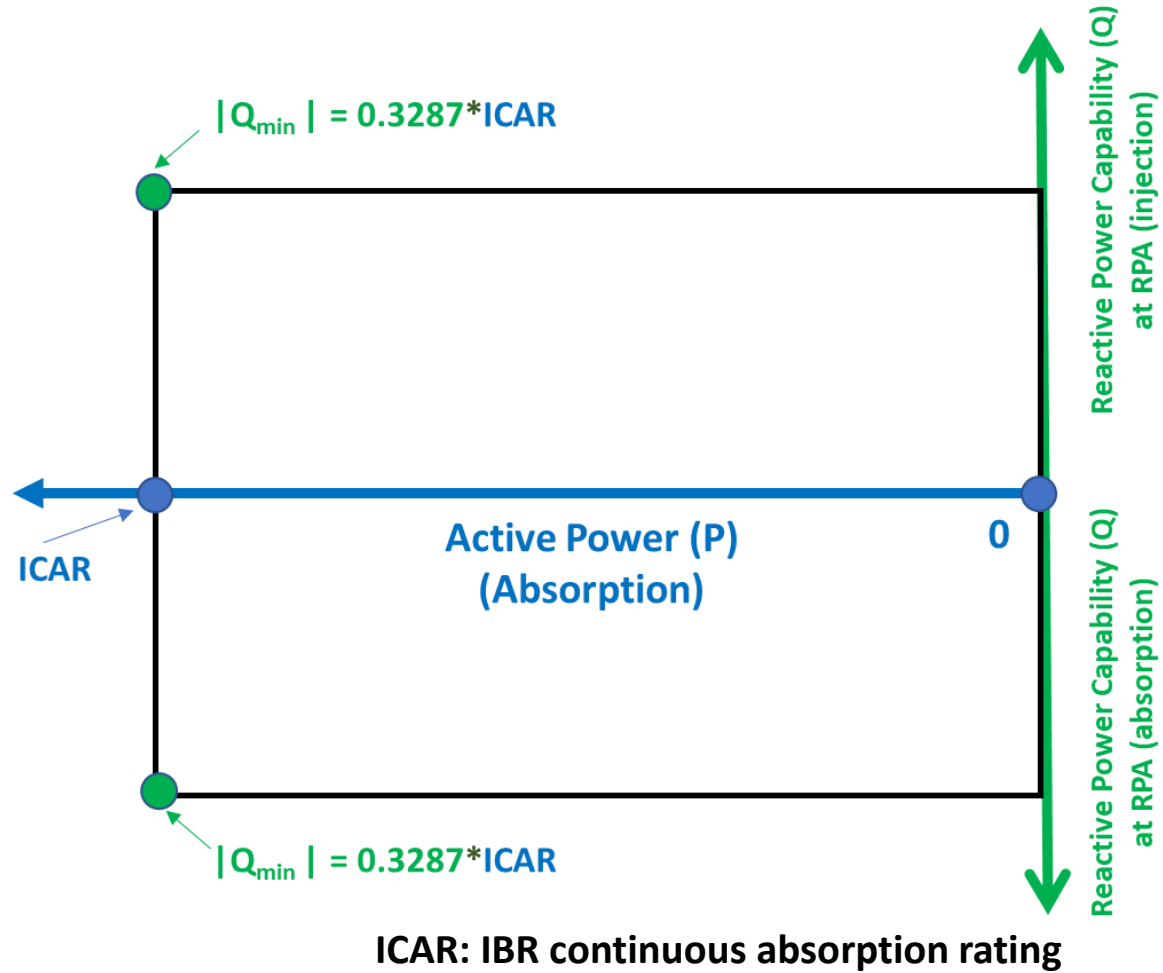

Reactive power (Q) capability at RPA Vs Voltage

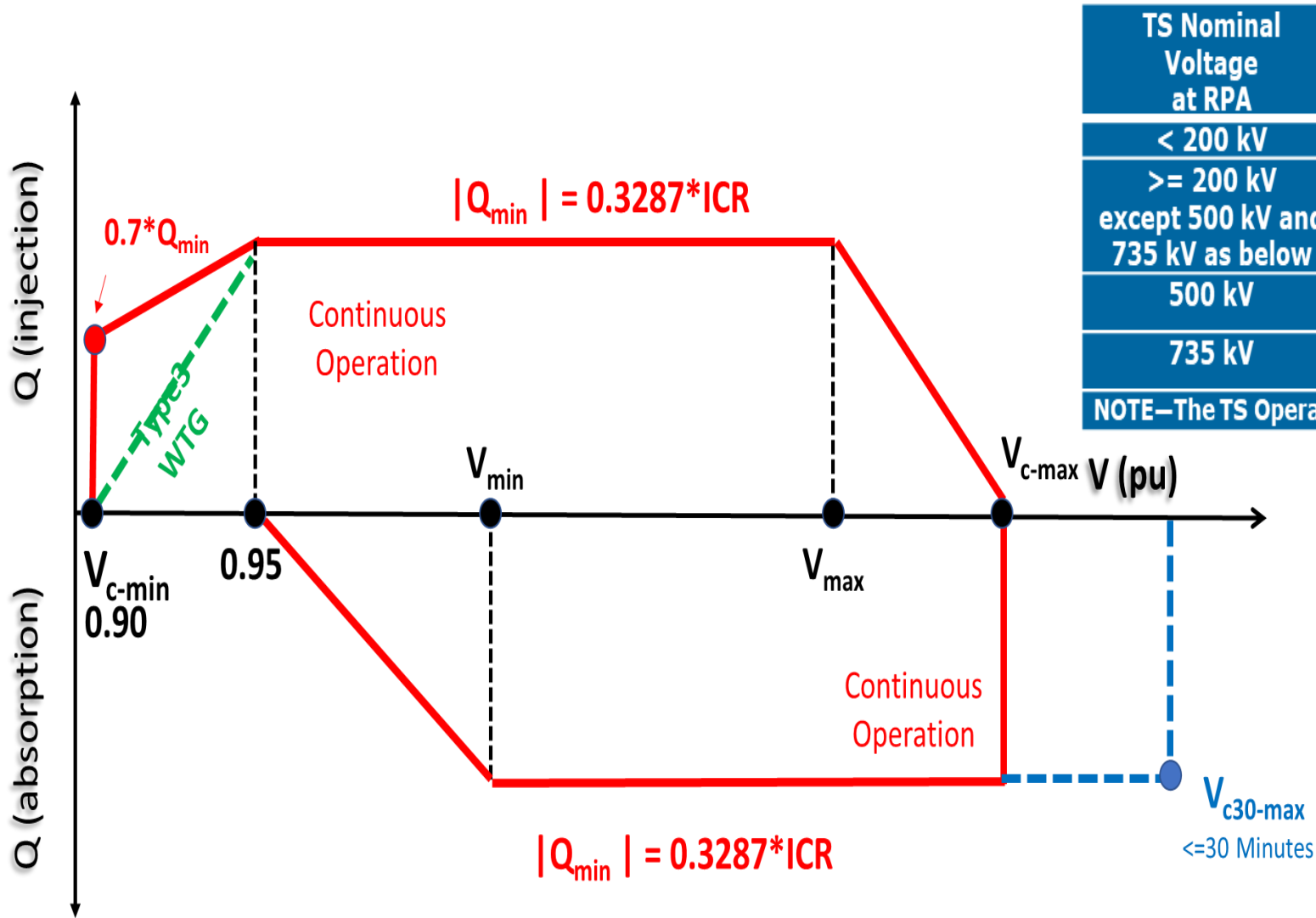

TS Nominal Voltage at RPA	V_{c-min} (p.u.)	V_{min} (p.u.)	V_{max} (p.u.)	V_{c-max} (p.u.)	$V_{c30-max}$ (p.u.)
< 200 kV	0.90	0.99	1.03	1.05	1.10
\geq 200 kV except 500 kV and 735 kV as below	0.90	1.00	1.04	1.05	1.10
500 kV	0.90	1.02	1.06	1.10	1.10
735 kV	0.90	1.02	1.06	1.088	1.10

NOTE—The TS Operator may require different values for the above quantities

Voltage Ride-Through Capability

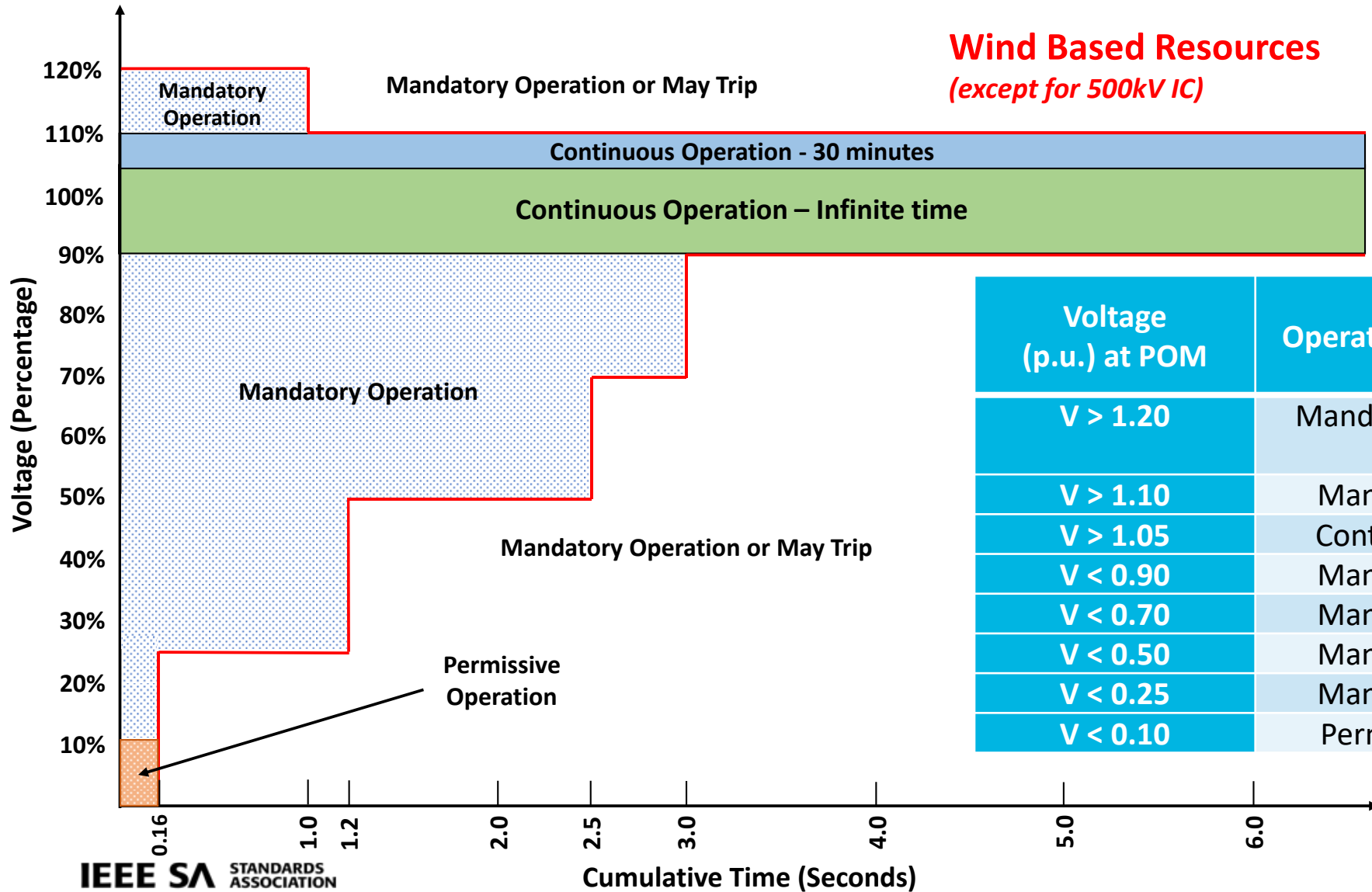

Voltage (p.u.) at POM	Operating mode/response	Minimum ride-through time (s) (design criteria)
$V > 1.20$	Mandatory Operation or May Trip	NA
$V > 1.10$	Mandatory Operation	1.0
$V > 1.05$	Continuous Operation	1800
$V < 0.90$	Mandatory Operation	3.00
$V < 0.70$	Mandatory Operation	2.50
$V < 0.50$	Mandatory Operation	1.20
$V < 0.25$	Mandatory Operation	0.16
$V < 0.10$	Permissive Operation	0.16

Voltage Ride-Through Performance

No specification of current magnitude

The 1-cycle time required for DFT (to derive phasor quantities) is included in specified response/settling time.

	Type III WTGs	All other IBR Units
Step Response Time	NA ¹	≤ 2.5 cycles
Settling Time	≤ 6 cycles	≤ 4 cycles
Settling Band	Max of (±10% of required change or ±2.5% of IBR unit maximum current)	Max of (±10% of required change or ±2.5% of IBR unit maximum current)

Note 1: Initial response is driven by machine characteristics, & not the control system.

Slower response/settling time is permitted with mutual agreement between TS owner and IBR owner.

Frequency Ride-Through Capability

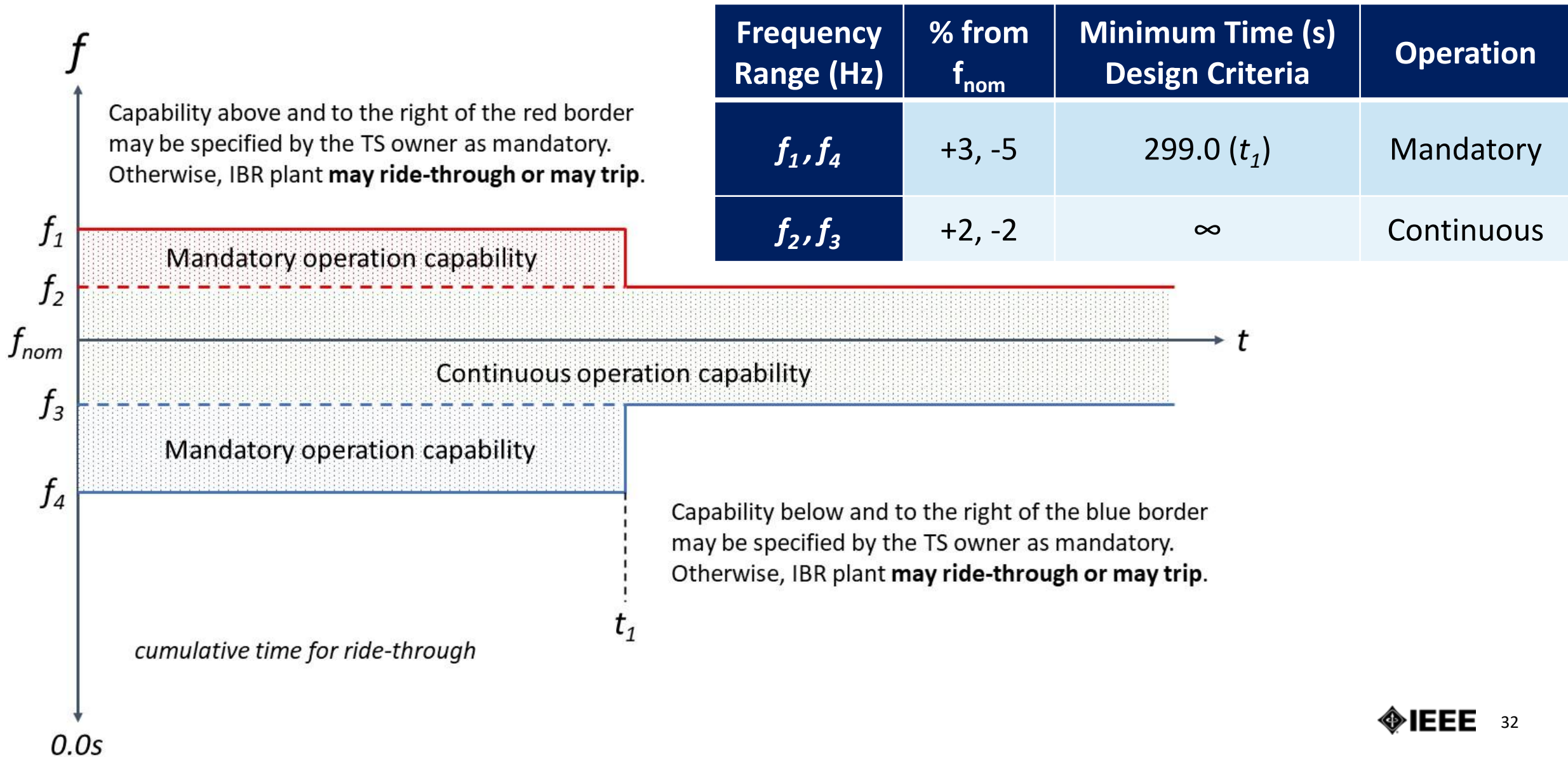

Fast Frequency Response (FFR)

FFR Capability of an IBR

- All IBR shall have FFR capability for under-frequency conditions
- FFR capability may be deployed for the purposes of ancillary service offering
- The FFR response time capability, shall be adjustable from 1 second or below including the reaction time for triggering FFR

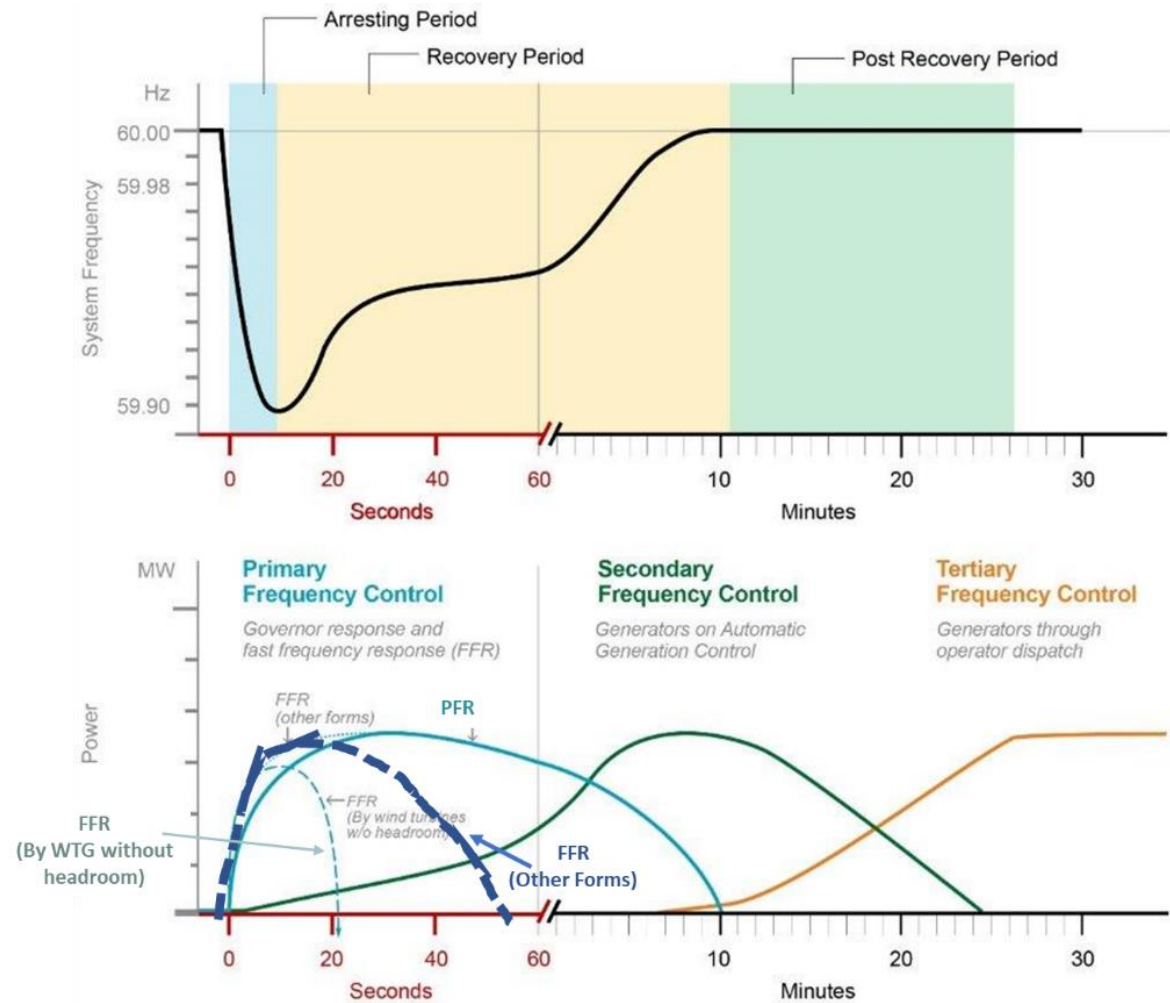

Transient overvoltage ride-through requirements

Over Voltage Ride-Through

- The IBR plant shall be capable to ride-through the higher of each phase-phase or phase-ground instantaneous voltages except for voltage magnitudes and cumulative durations specified in Table and illustrated in the informative Figure

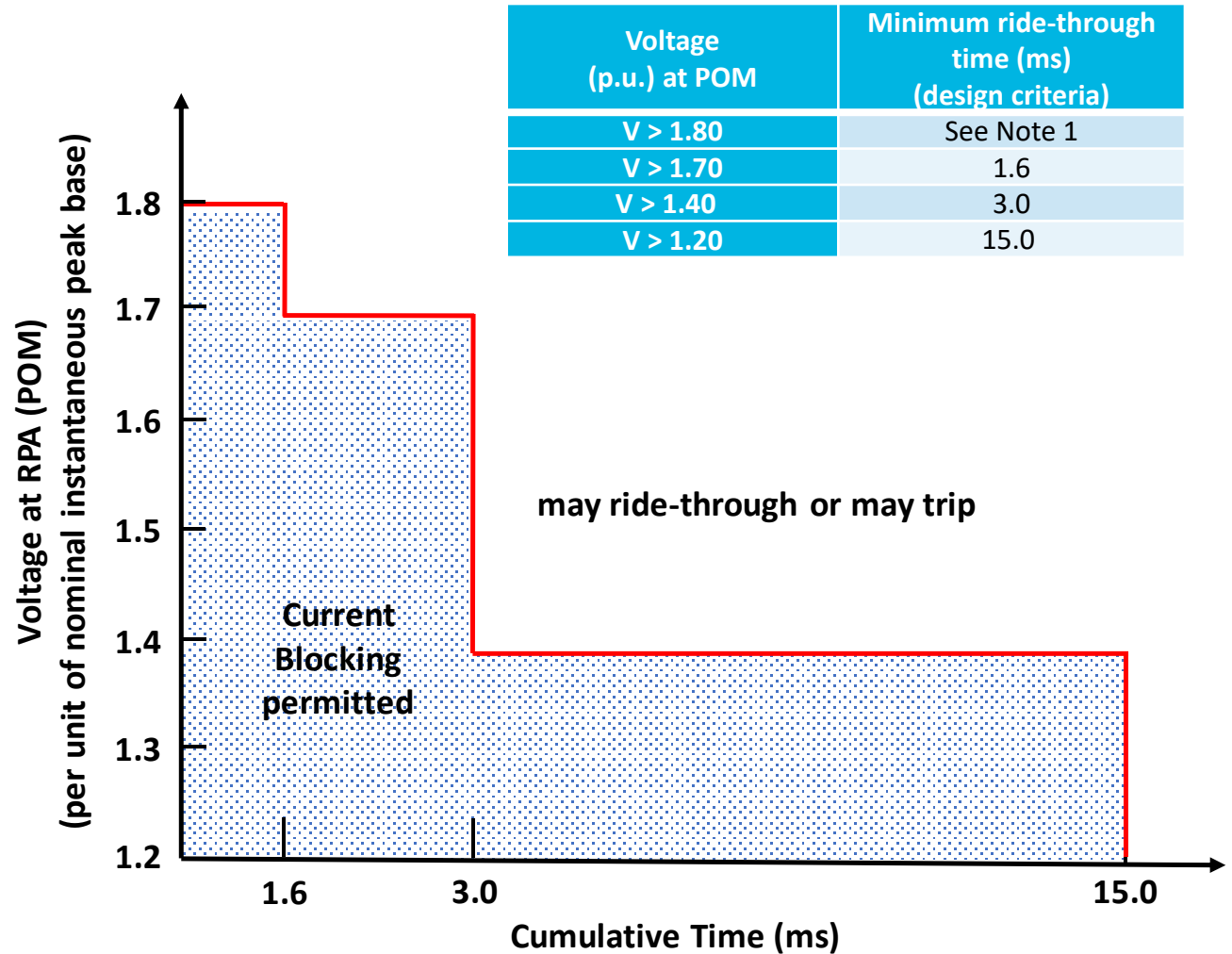
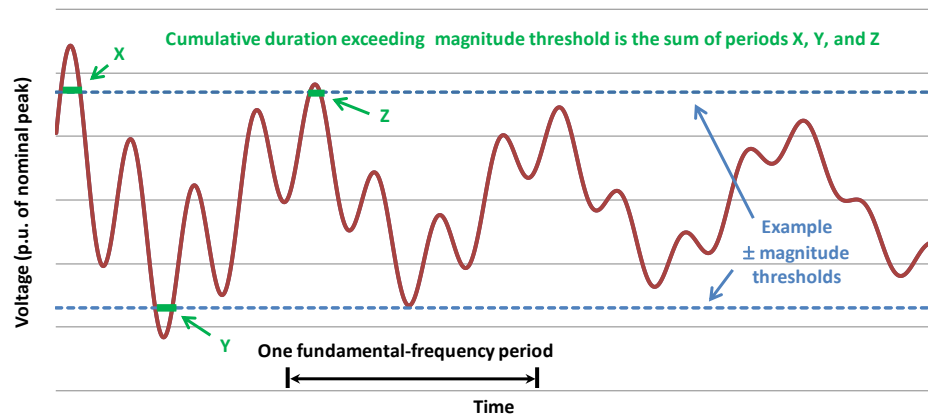

Scope and Language of P2800 Requirements

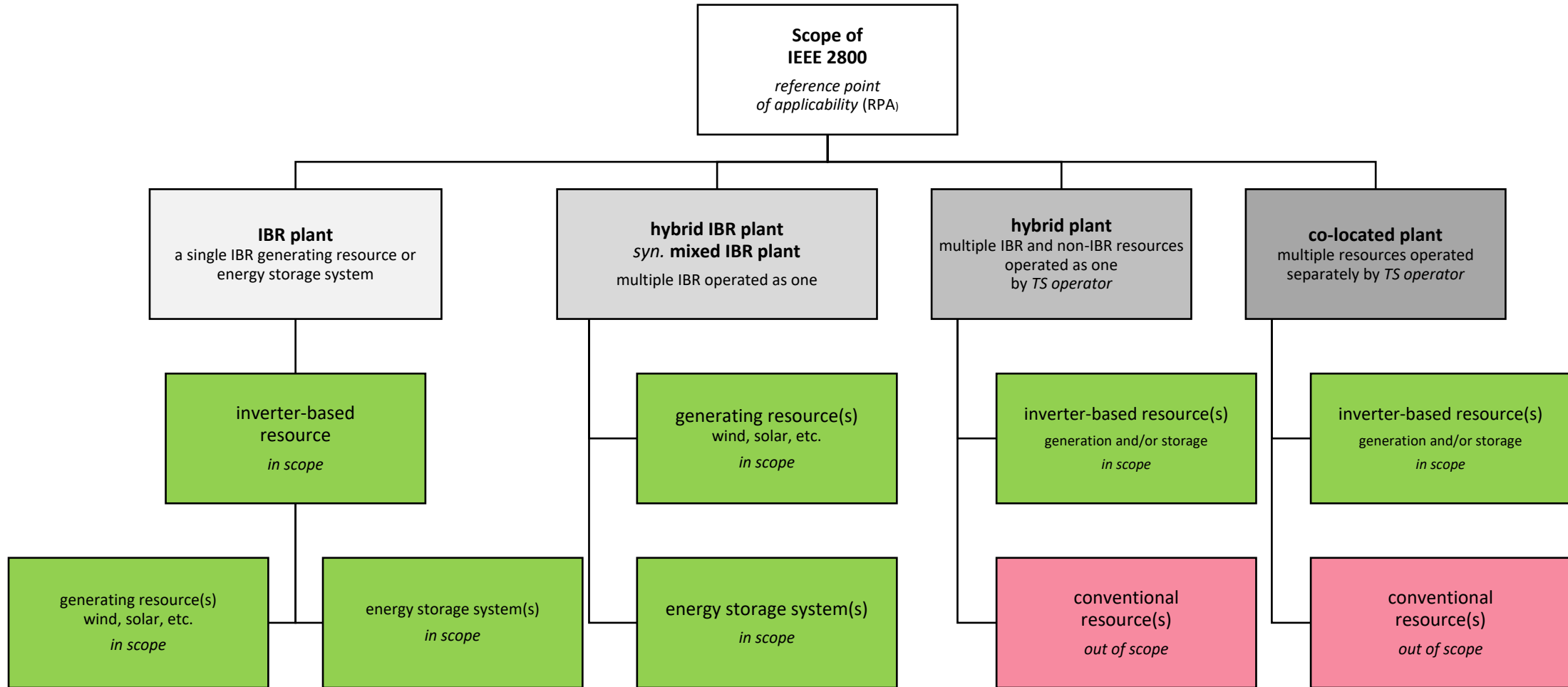

Example *hybrid IBR plant, ac-coupled*

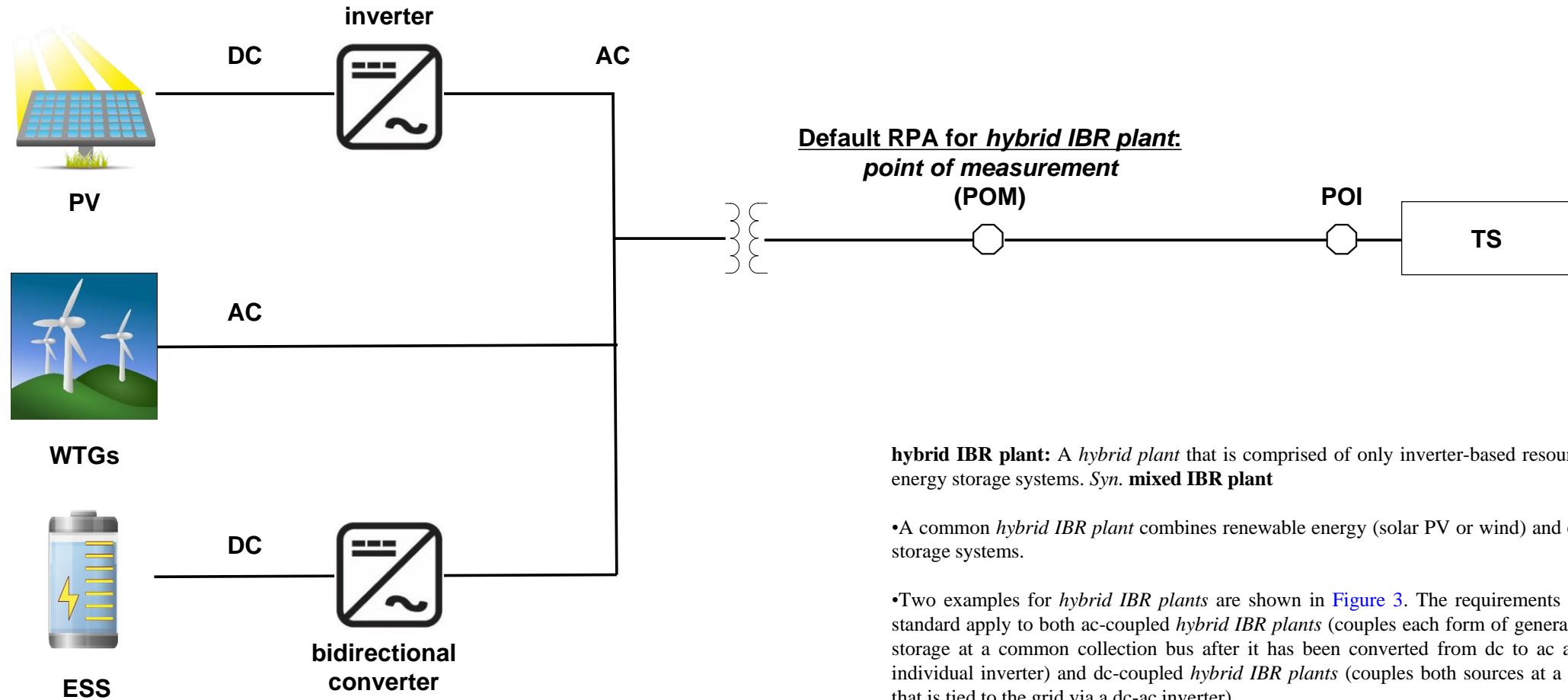

hybrid IBR plant: A *hybrid plant* that is comprised of only inverter-based resources or energy storage systems. *Syn. mixed IBR plant*

- A common *hybrid IBR plant* combines renewable energy (solar PV or wind) and energy storage systems.

- Two examples for *hybrid IBR plants* are shown in [Figure 3](#). The requirements of this standard apply to both ac-coupled *hybrid IBR plants* (couples each form of generation or storage at a common collection bus after it has been converted from dc to ac at each individual inverter) and dc-coupled *hybrid IBR plants* (couples both sources at a dc bus that is tied to the grid via a dc-ac inverter).

Example *hybrid plant*

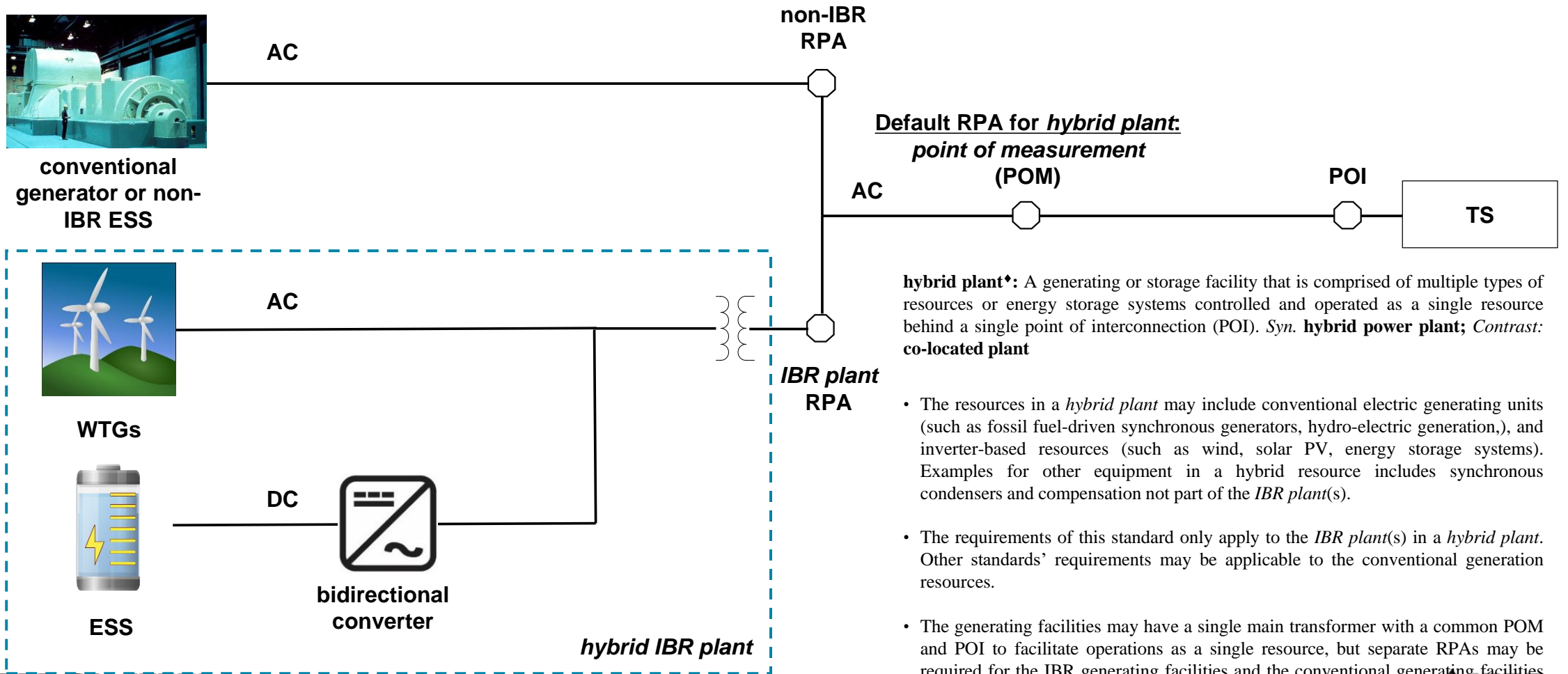

Default RPA for *hybrid plant*:
point of measurement (POM)

hybrid plant[♦]: A generating or storage facility that is comprised of multiple types of resources or energy storage systems controlled and operated as a single resource behind a single point of interconnection (POI). *Syn. hybrid power plant; Contrast: co-located plant*

- The resources in a *hybrid plant* may include conventional electric generating units (such as fossil fuel-driven synchronous generators, hydro-electric generation,) and inverter-based resources (such as wind, solar PV, energy storage systems). Examples for other equipment in a hybrid resource includes synchronous condensers and compensation not part of the *IBR plant(s)*.
- The requirements of this standard only apply to the *IBR plant(s)* in a *hybrid plant*. Other standards' requirements may be applicable to the conventional generation resources.
- The generating facilities may have a single main transformer with a common POM and POI to facilitate operations as a single resource, but separate RPAs may be required for the IBR generating facilities and the conventional generating facilities to facilitate measurement of compliance to applicable standards.

Example *co-located plant* : operated as separate resources

in scope

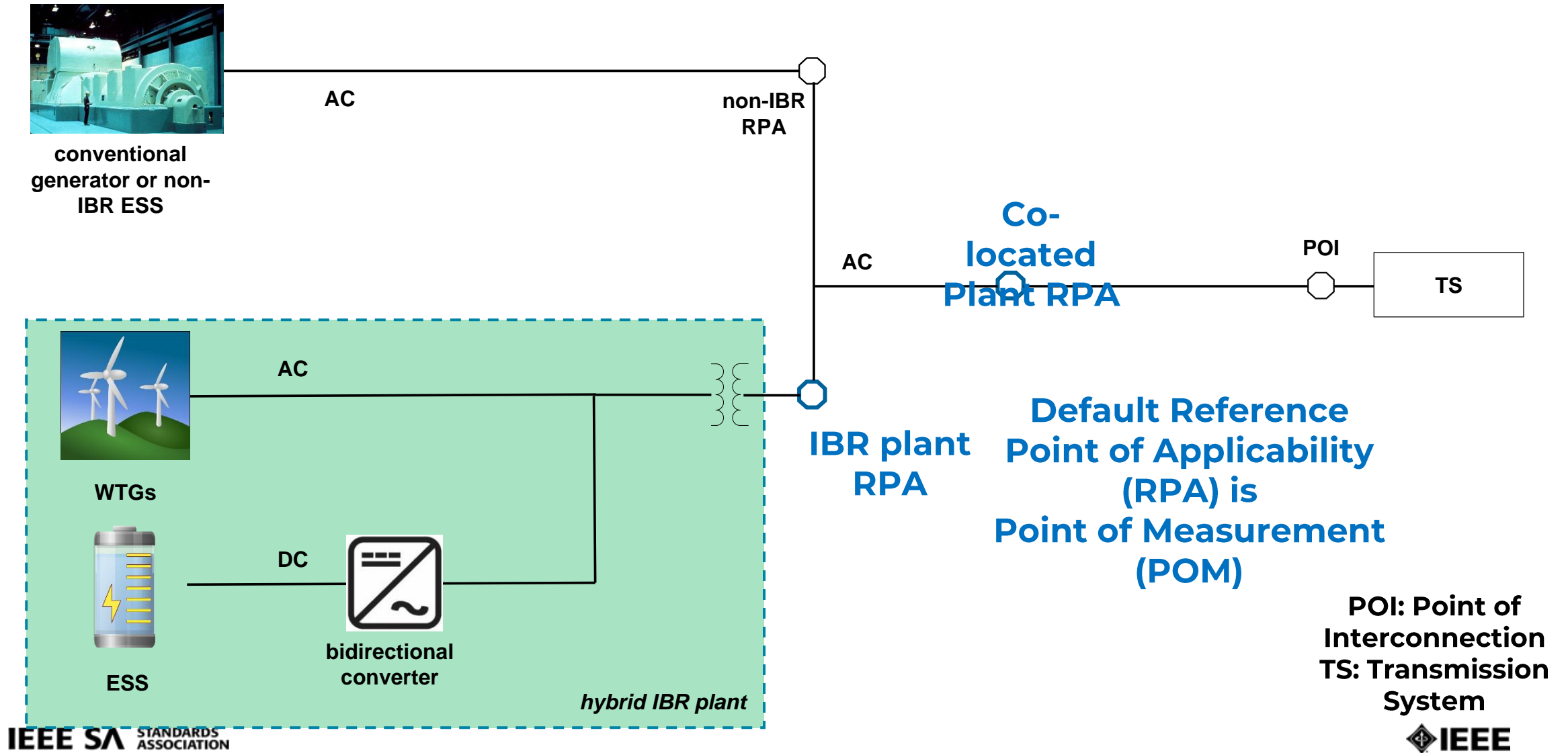

Example *co-located plant*

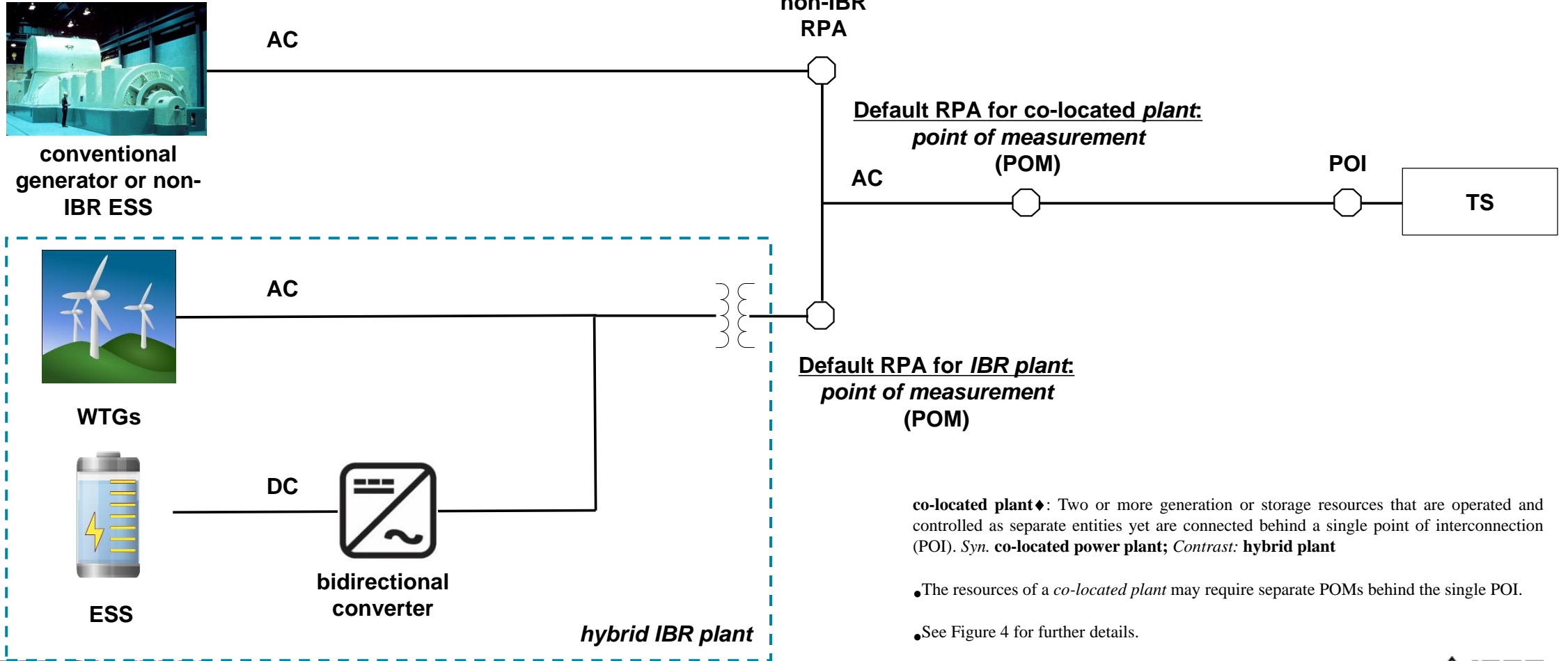

co-located plant ♦: Two or more generation or storage resources that are operated and controlled as separate entities yet are connected behind a single point of interconnection (POI). *Syn. co-located power plant; Contrast: hybrid plant*

- The resources of a *co-located plant* may require separate POMs behind the single POI.
- See Figure 4 for further details.

Example *IBR plant* with Sync. condenser as *supplemental IBR device*

