

SSO/SSCI Example study

750 MW PV + 750MW GFM BESS Project
Heavily series compensated system

Network Topology

- 500 kV System

Presence of multiple series resonance modes within the 15 Hz to 48 Hz range

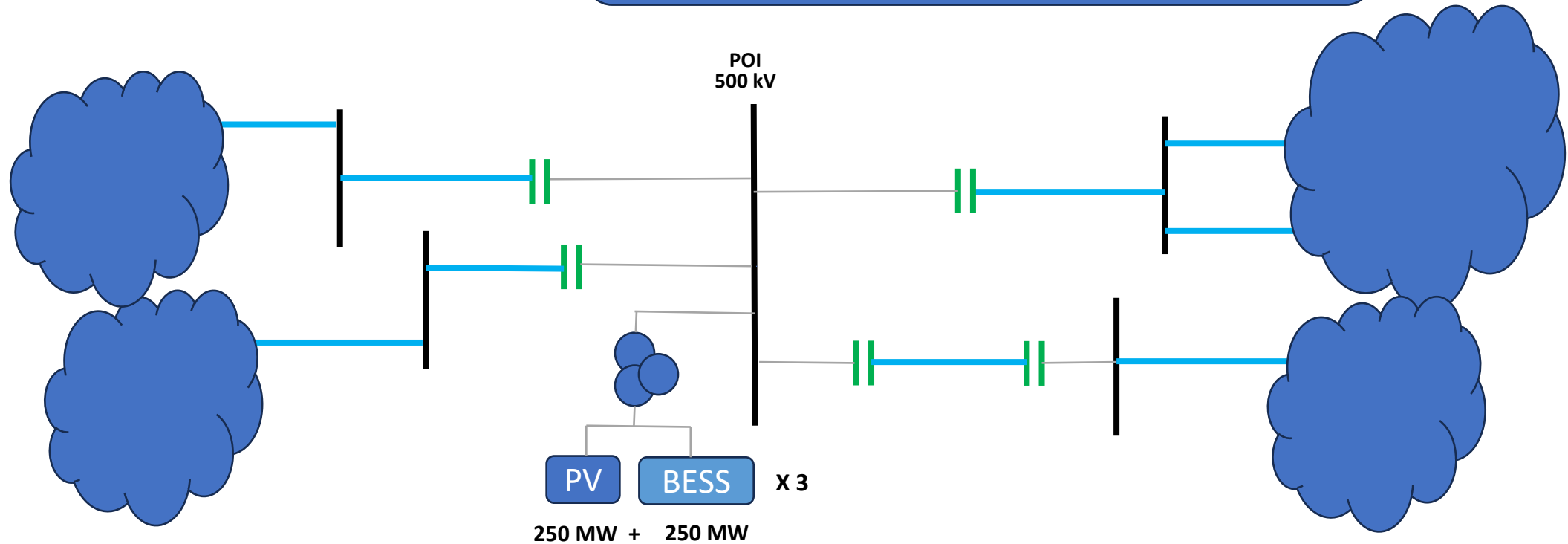

Detailed System and Plant EMT Model

- Three equivalent feeders with 250 MW each (750 MW)
- Equivalent collector systems
- Detailed custom tuned OEM PV inverter and GFM BESS Inverter
- Detailed custom tuned OEM PPC to site conditions
- Transformer Neutral Grounding Reactors (NGR)
- Plant HV and MV arresters
- Transformer Saturation
- Series Capacitors with MOV and protection
- Detailed transmission line models

Screening: Passive Frequency Scan

System side

- The passive frequency scanning method looks for electrical resonances in the system in the range of 2 Hz to 55 Hz.
- Series system resonances can be observed when a series compensated line is radially or near radially connected to a generator.
- If a generator is radial to a series compensated line then the system inductance is negative at lower frequencies and turns positive above the series resonance frequency.
- If a generator is connected to a series compensated line parallel with other lines (or shunt devices), then a dip in the reactance can be observed.

Radial
Case to
series
capacitor

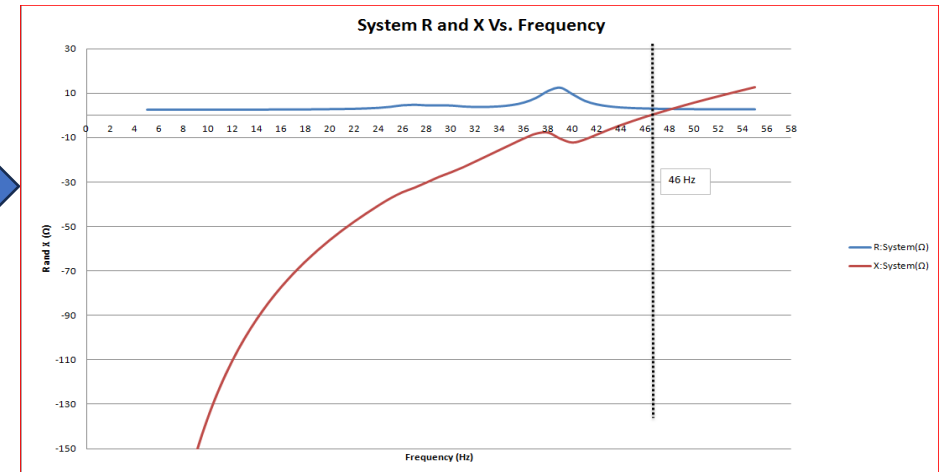

Near
Radial
Case to
series
capacitor

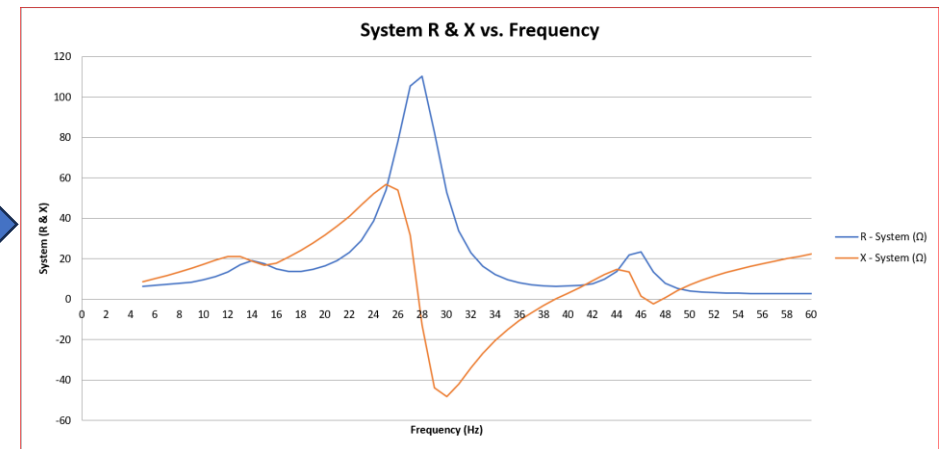

Screening : Dynamic Frequency Scan

IBR Side

- Small magnitude voltage harmonics are injected to the fundamental waveform at the POI of an IBR plant at a range of sub-synchronous frequencies.
- R and X values are calculated at the IBR plant terminal for each sub-synchronous frequency.

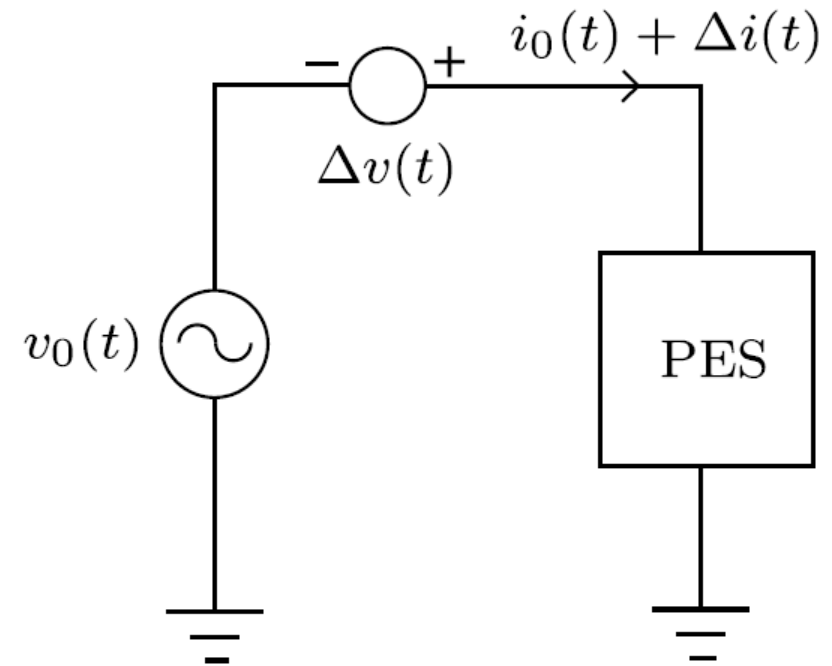

Dynamic Frequency Scan Results

750 MW PV

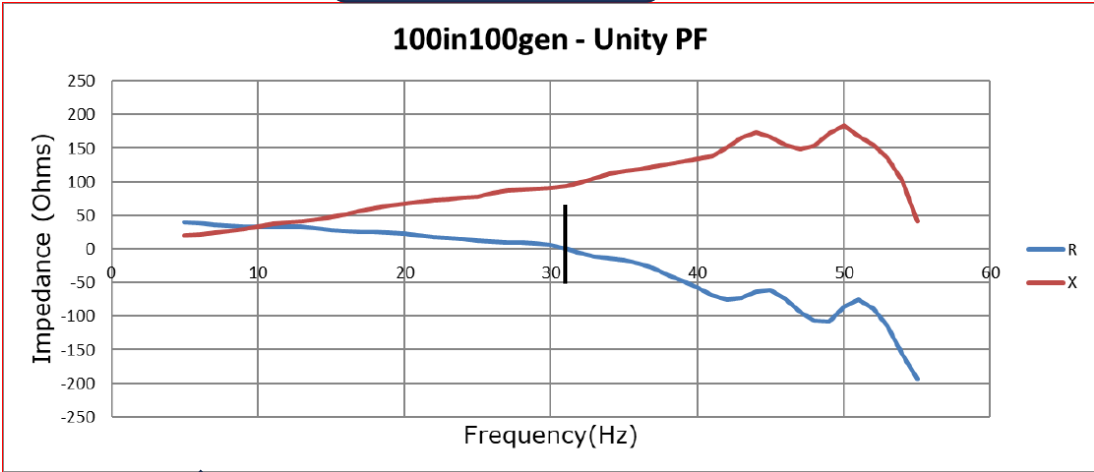

750 MW GFM BESS

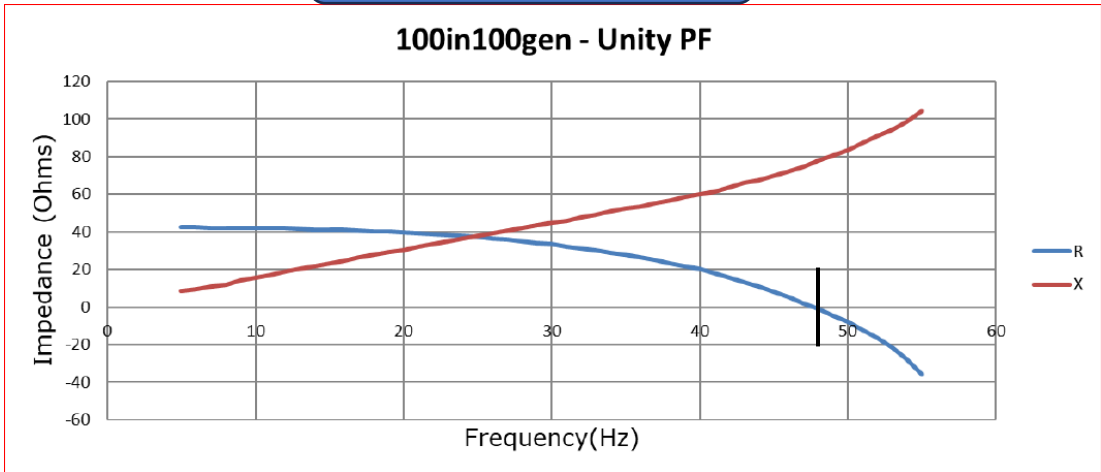

R becomes negative at 32 Hz

R becomes negative at 45 Hz

750 MW PV + 750 MW GFM BESS

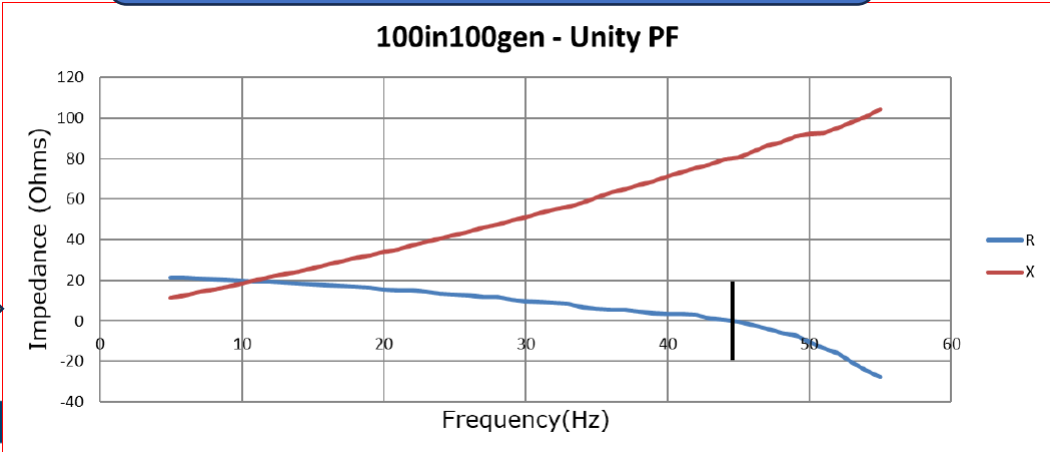

R becomes negative at 48 Hz

Contingency Selection

Adding Dynamic and Passive Scan Results

- Dynamic impedance scans of the inverters and system impedances can be added together to estimate the overall damping and resonant frequencies for critical contingencies. (Caution is required, there are approximations built into this!).
- It is important to note that these are screening techniques. All final conclusions must be based on fully detailed time domain simulations of critical contingencies.

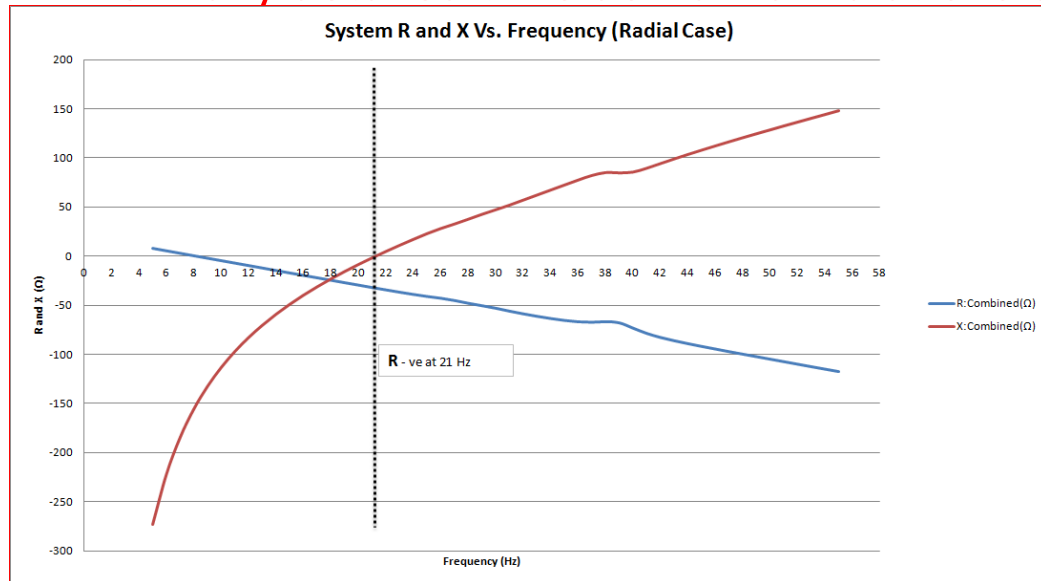

Unstable SSCI

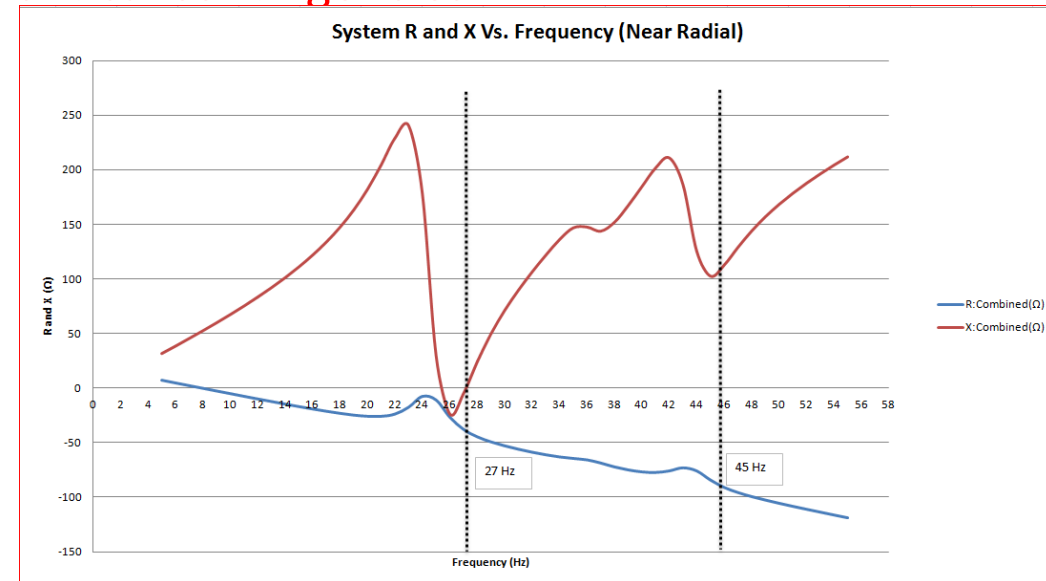

Unstable SSCI

What are the Worst-Case Contingencies ?

Resonant Frequency

$$f_r = \frac{1}{2\pi\sqrt{LC}} \text{ (Hz)}$$

L : Total inductance
C : Total Capacitance

- Adding more generation
- Additional network expansion



- Unstable SSCI Frequency range

- Adding more series Compensation in **Series**



- Unstable SSCI Frequency range

- Adding more series Compensation in **Parallel**



- ?

Screening Analysis Results

- Having all series capacitors in service does not represent the worst-case scenario for SSCI – **Location and topology specific**
- The most severe resonance and highest negative damping occur when the system is radial to a single series capacitor – **Location and topology specific**

Detailed Time-Domain Results

750 MW PV Only in-service

- Post fault SSCI and subsequent ride-through failure under N-3 conditions caused by phase overvoltage
- SSFR concerns under N-3 conditions: It was recommended to install and properly tune a sub-synchronous detection relay to disconnect the plant during SSFR events.
- The plant's inability to ride through faults masks underlying SSCI issues associated with the PV system.

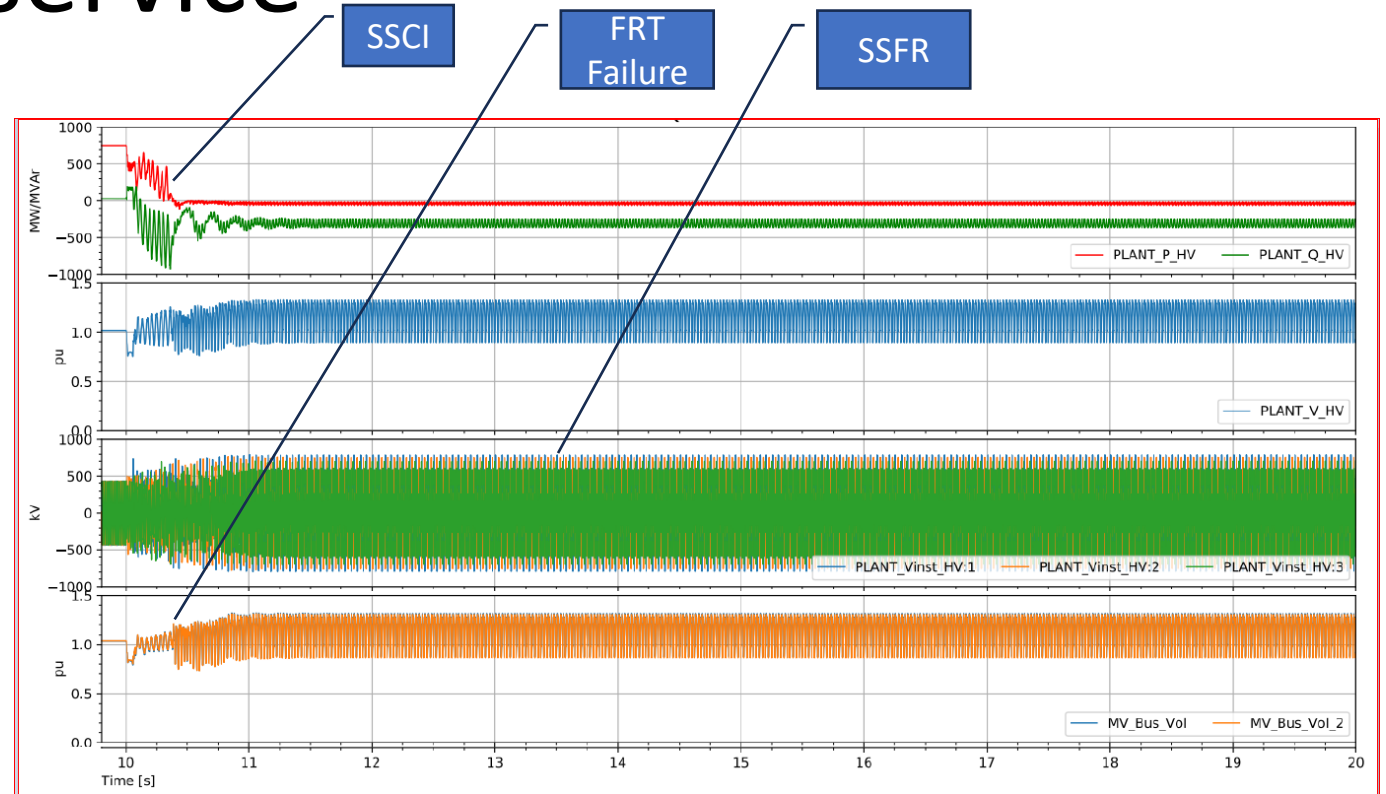

Post fault SSCI and subsequent ride through failure and SSFR Oscillations

Unacceptable

Detailed Time-Domain Results

750 MW BESS Only in-service

- Post fault ride-through failure under N-3 conditions caused by phase overvoltage : Acceptable under IEEE - P2800
- SSFR concerns under N-3 conditions: It was recommended to install and properly tune a sub-synchronous detection relay to disconnect the plant during SSFR events.
- No SSCI Oscillations

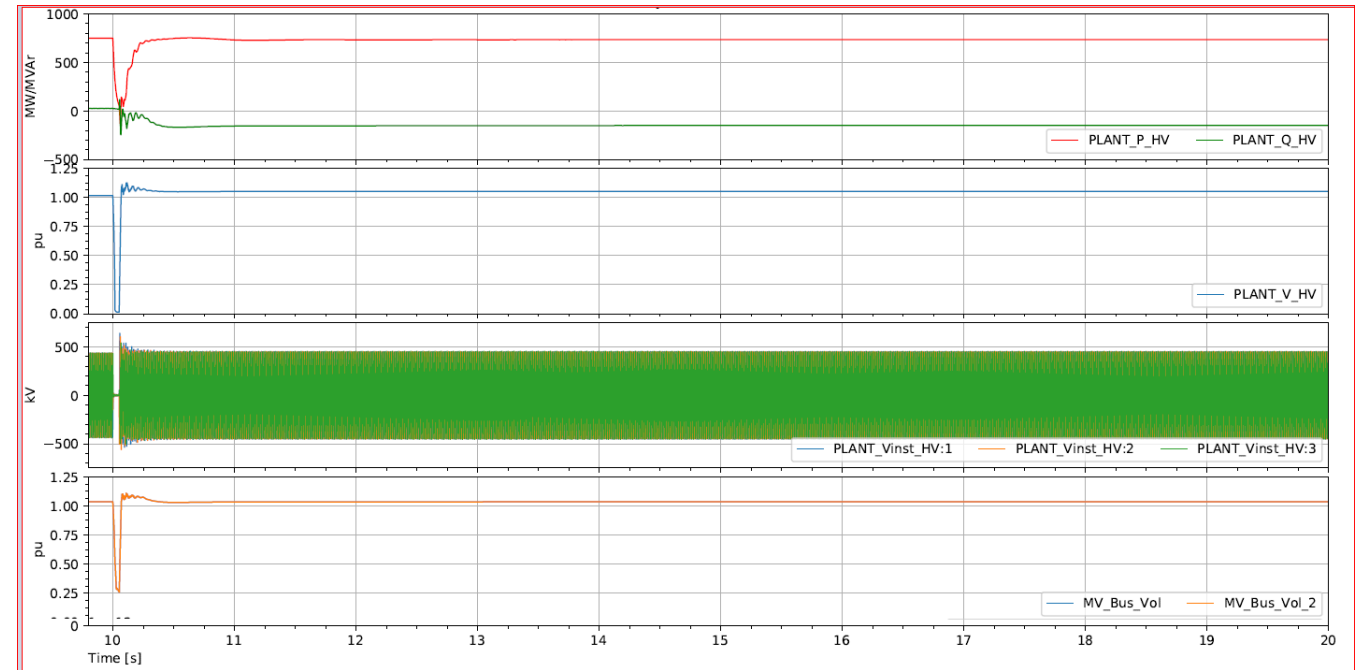

Acceptable

Detailed Time-Domain Results

750 MW PV + 187 MW GFM BESS (25% units) in service

- Post fault SSCI and subsequent ride-through failure under N-3 conditions caused by phase overvoltage
- SSFR concerns under N-3 conditions: It was recommended to install and properly tune a sub-synchronous detection relay to disconnect the plant during SSFR events.
- The plant's inability to ride through faults masks underlying SSCI issues associated with the PV system.

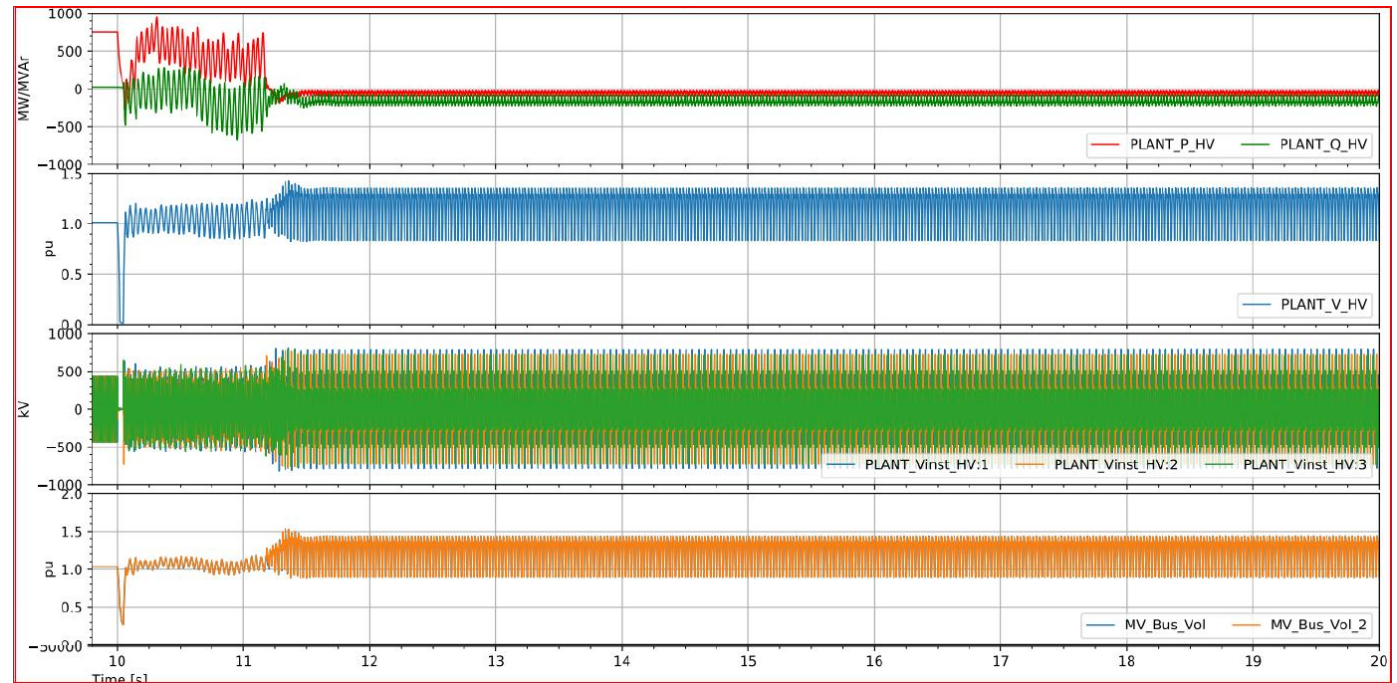

Post fault SSCI and subsequent ride through failure and SSFR Oscillations

Unacceptable

Detailed Time-Domain Results

750 MW PV + 375 MW GFM BESS (50% units) in service

- Successful plant Ride Through for all selected contingencies
- No SSFR Oscillations
- No SSCI oscillations

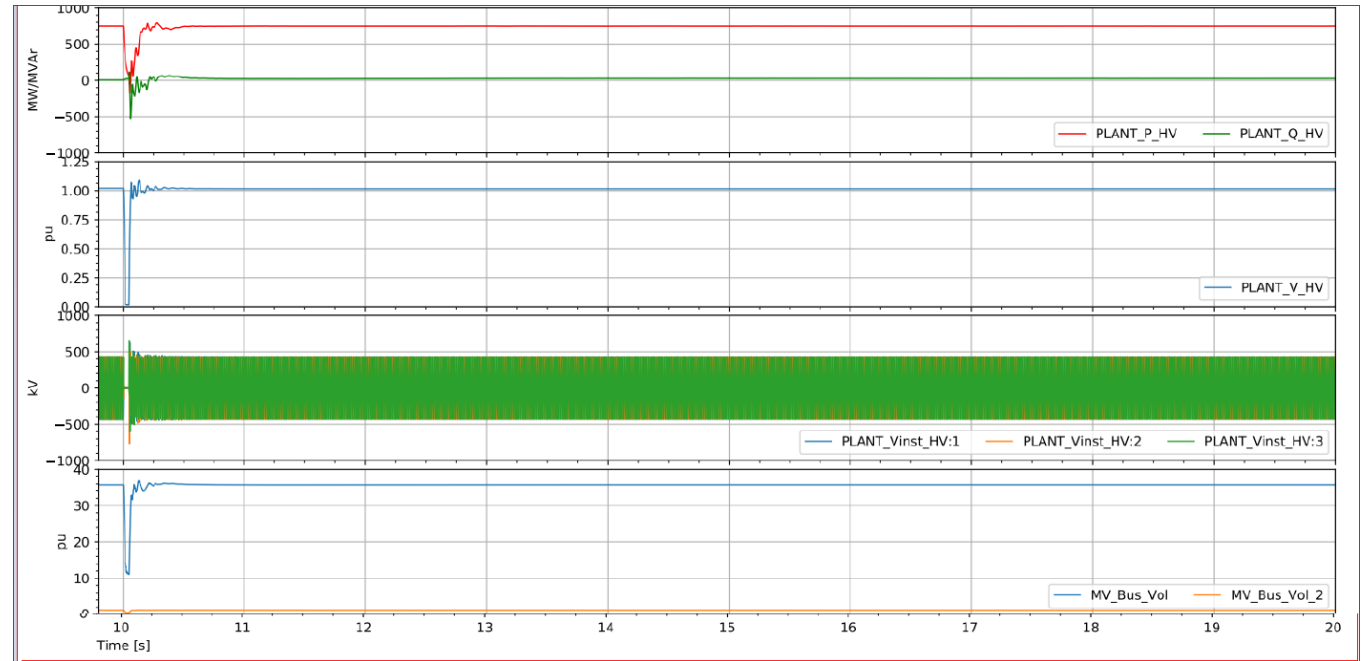

Acceptable

Recommendations

- To ensure SSCI stability under current system conditions, at least 50% of the BESS GFM inverters must remain in operation.
- It is recommended to install and accurately tune a sub-synchronous detection relay to trip the plant during SSFR events.
- Enhance the SSCI performance of the PV inverter through additional tuning .
- It is strongly recommended to update the inverter firmware to reflect the parameters of the tuned EMT model.
- Perform a cluster-based SSCI EMT study that includes other nearby plants in the interconnection queue.